

AC Spindle Servo Unit S Series

Maintenance Manual

GE Fanuc Automation

GFZ-65015E/01

WARNING

The product described in this publication may employ hazardous voltages or might create other conditions that could, through misuse, inattention, or lack of understanding, result in personal injury, or damage to the product or to other equipment. It is imperative, therefore, that personnel involved in the installation, maintenance, or use of this product understand the operation of the product and the contents of this publication.

This document is based on information available at the time of its publication. While efforts have been made to be accurate, the information contained herein does not purport to cover all details or variations in hardware and software, nor to provide for every possible contingency in connection with installation, operation, and maintenance. Features may be described herein which are not present in all hardware and software systems. Neither GE Fanuc Automation Corporation nor any of its subsidiaries assumes any obligation of notice to holders of this document with respect to changes subsequently made.

Neither GE Fanuc Automation Corporation nor any of its subsidiaries makes any representation or warranty, expressed, implied, or statutory with respect to, and none assumes any responsibility for the accuracy, completeness, sufficiency, or usefulness of the information contained herein. No warranties of merchantability or fitness for purpose shall apply.

This manual describes following products:

Series name	Model name
S series AC spindle servo unit	Model 1S, Model 1.5S, Model 2S, Model 3S, Model 6S, Model 8S, Model 12S, Model 15S, Model 18S, Model 22S

TABLE OF CONTENTS

I. S SERIES AC SPINDLE SERVO UNIT

1. GENERAL	3
1.1 Configurations	3
1.1.1 Models 1S - 3S	3
1.1.2 Models 6S - 22S	4
1.2 Major Components	5
2. DAILY MAINTENANCE AND MAINTENANCE TOOLS	7
2.1 AC Spindle Motor	7
2.2 AC Spindle Servo Unit	7
2.3 Maintenance Tools	7
2.4 Major Maintenance Parts	7
3. TROUBLESHOOTING	8
3.1 Power Voltage Check	8
3.2 Power On Indicator Lamp PIL is not Lit	9
3.3 Alarm is Indicated	10
3.4 Motor does not Rotate or its Rotation is Abnormal	17
3.5 Vibrations or Noises is too Large during Rotation	18
3.6 Noise is Produced from Motor during Deceleration	18
3.7 Speed Overshooting or Hunting Occurs	18
3.8 Cutting Force is Low	18
3.9 Orientation is not Correct	19
3.10 Acceleration/Deceleration Time is Long	19
4. INSTALLATION	20
4.1 Installation Procedure	20
4.2 Power Connection	21
4.2.1 Power voltage and capacity check	21
4.2.2 Protective earth connection	21
4.2.3 Power connection	21
4.3 AC Spindle Motor Connection	21
4.4 Single Cable Connection	21
5. SETTING AND ADJUSTING	22
5.1 Jumper and Variable Resistor on Spindle Control PCB (models 1S - 3S)	22
5.2 Jumper on Spindle Control Circuit (models 6S - 22S)	23
5.3 Parameter Setting Method	23
5.4 Number and Content of Parameter	24
5.5 Setting Rank (models 1S - 3S)	34
5.6 Setting Rank (models 6S - 22S)	34
5.7 Setting and Adjusting Spindle Orientation Control Circuit (option)	35
6. REPLACING FUSE AND PCB	36
6.1 Replacing Fuse	36
6.2 Replacing Spindle Control Circuit and Control Circuit PCB	36
6.3 Replacing Spindle Orientation Control Circuit PCB	36
6.4 Replacing Transistor Module	37
7. SPINDLE ORIENTATION CONTROL CIRCUIT	39
7.1 Configuration	39
7.2 Adjusting Spindle Orientation Control Circuit of Position Coder System	40

7.2.1	Setting and adjusting spindle orientation control circuit in 2-step spindle speed change or less	40
7.3	Adjusting Spindle Orientation Control Circuit of Magnetic Sensor Type	45
7.3.1	Mounting magnetizing element and magnetic sensor	45
7.3.2	Setting and adjusting spindle orientation control circuit in 2-step speed spindle for standard type	45
7.3.3	Setting and adjusting spindle orientation control circuit in 2-step speed spindle for high speed type	53
7.3.4	Checking method of spindle position loop gain	58

APPENDIX

APPENDIX 1	CONNECTION DIAGRAM	61
APPENDIX 2	CABLE ROUTING	72
APPENDIX 3	CABLE SPECIFICATIONS	75
APPENDIX 4	CONFIGURATION OF SPINDLE CIRCUIT	77
APPENDIX 5	LOCATION OF UNIT	78
APPENDIX 6	LOCATION OF PCB	81
APPENDIX 7	MAJOR PARTS	83
APPENDIX 8	MAGNETIC SENSOR SIGNALS CHECKING METHOD	85
APPENDIX 9	PARAMETER LIST	86

I. S SERIES AC SPINDLE SERVO UNIT

1. GENERAL

This manual describes maintenance of S series AC spindle servo units (models 1S, 1.5S, 2S, 3S, 6S, 8S, 12S, 15S, 18S and 22S).

1.1 Configurations

1.1.1 Models 1S - 3S

Models 1S - 3S of S series AC spindle servo units consist of the following units.

- 1) Spindle control unit (basic)
- 2) Resistor unit (basic)
- 3) Spare fuse (basic)
- 4) Connector for connection (basic)
- 5) Spindle orientation control circuit (option)
- 6) AC line filter (option)
- 7) Power transformer (option)

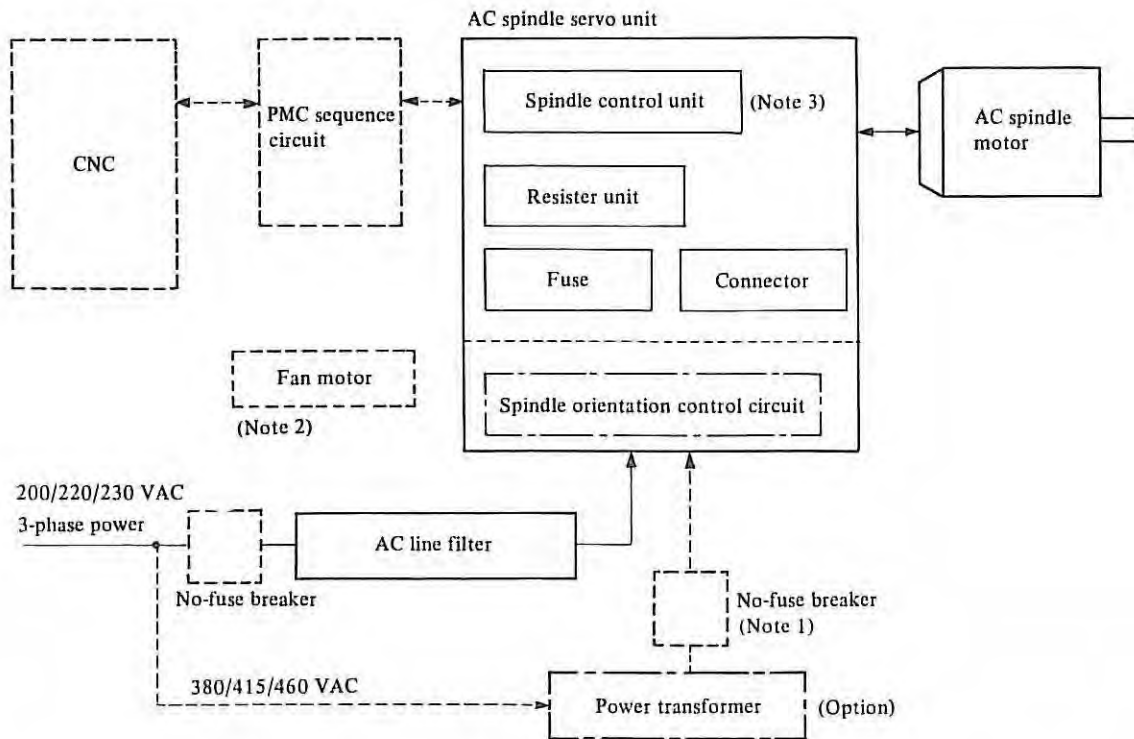

Note 1) An overcurrent protector (no-fuse breaker, etc.) is provided by the MTB for the input circuit of S series spindle servo unit.

Note 2) Cool the spindle control unit using a fan motor having a specific wind speed. Refer to Descriptions manual.

Note 3) For the PCB configuration refer to Appendix 2.

1.1.2 Models 6S - 22S

Models 6S - 22S of S series AC spindle servo units consist of the following units.

- 1) Spindle control unit (basic)
- 2) Spare fuse (basic)
- 3) Connector for connection (basic)
- 4) Power transformer (option)
- 5) Spindle orientation control circuit (option)
- 6) Unit adapter (option)

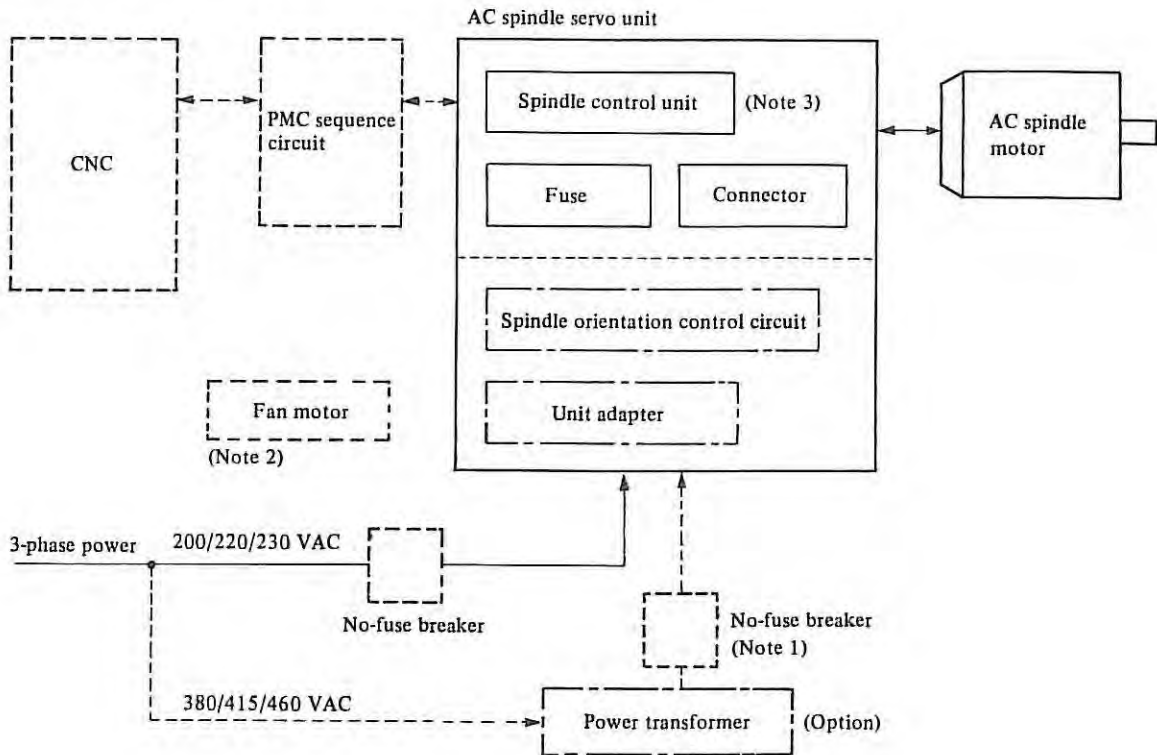

Note 1) An overcurrent protector (no-fuse breaker, etc.) is provided by the MTB for the input circuit of S series spindle servo unit.

Note 2) Cool the spindle control unit using a fan motor having a specific wind speed. Refer to Descriptions manual.

Note 3) For PCB configuration refer to Appendix 2.

1.2 Major Components

Table 1.2 (a) Major components

Model	Order specification	Unit	PCB	ROM		
				Specification	Type	
1S 8000rpm	A06B-6059-H002#H501	A06B-6059-H002	A16B-1100 -0200 (PCB1) + A16B-1100 -0240 (PCB2)	A06B-6059-H501	9801	
1.5S 8000rpm	A06B-6059-H002#H508	A06B-6059-H002		A06B-6059-H508	9808	
2S 8000rpm	A06B-6059-H002#H502	A06B-6059-H002		A06B-6059-H502	9802	
3S 6000rpm	A06B-6059-H003#H503	A06B-6059-H003		A06B-6059-H503	9803	
6S/A3 6000rpm	A06B-6059-H203#H523	A06B-6059-H203	A20B-1003 -0010 (PCB1) + A20B-1003 -0020 (PCB2)	A06B-6059-H523	9823	
6S 6000rpm	A06B-6059-H206#H511	A06B-6059-H206		A06B-6059-H511	9811	
8S 4500rpm	A06B-6059-H208#H512	A06B-6059-H028		A06B-6059-H512	9812	
8S 6000rpm	A06B-6059-H208#H513	A06B-6059-H028		A06B-6059-H513	9813	
12S/A8 4500rpm	A06B-6059-H208#H524	A06B-6059-H208		A06B-6059-H524	9824	
12S/A8 6000rpm	A06B-6059-H208#H525	A06B-6059-H208		A06B-6059-H525	9825	
12S 4500rpm	A06B-6059-H212#H514	A06B-6059-H212		A06B-6059-H514	9814	
12S 6000rpm	A06B-6059-H212#515	A06B-6059-H212		A06B-6059-H515	9815	
15S 4500rpm	A06B-6059-H215#H516	A06B-6059-H215		A20B-1003 -0010 (PCB1) + A20B-1003 -0120 (PCB2)	A06B-6059-H516	9816
15S 6000rpm	A06B-6059-H215#H517	A06B-6059-H215			A06B-6059-H517	9817
18S 4500rpm	A06B-6059-H218#H518	A06B-6059-H218	A06B-6059-H518		9818	
22S 4500rpm	A06B-6059-H222#H520	A06B-6059-H222	A06B-6059-H520		9820	

Table 1.2 (b) Major components (option) (models 1S - 3S)

Name	Order specifications	PCB
Orientation ARII (Position coder, 2-stage speed change)	A06B-6059-J110	A20B-0008-0242
Orientation BRII (Position coder, 2-stage speed change)	A06B-6059-J111	A20B-0008-0243
Orientation CR (Magnetic sensor, 2-stage speed change)	A06B-6059-J120	A16B-1300-0110
Orientation GR (Magnetic sensor, 2-stage speed change)	A06B-6059-J121	A20B-0008-0111

Table 1.2 (c) Major components (option) (models 6S - 22S)

Name	Order specifications	PCB
Orientation ASII (Position coder, 2-stage speed change)	A06B-6059-J130	A20B-0008-0242
Orientation BSII (Position coder, 2-stage speed change)	A06B-6059-J131	A20B-0008-0243
Orientation CSII (Magnetic sensor, 2-stage speed change)	A06B-6059-J140	A20B-0008-0032
Orientation GSII (Magnetic sensor, 2-stage speed change)	A06B-6059-J141	A20B-0008-0033

2. DAILY MAINTENANCE AND MAINTENANCE TOOLS

Check and clean the following items once every 6 months or so for using the AC spindle motor and AC spindle servo units under a normal condition for a long time.

Take the check frequency into consideration according to the contamination degrees in each item.

2.1 AC Spindle Motor

If the ventilation hole, cooling fan, and fan finger guard (net) of the AC spindle motor become dusty, the radiation efficiency of the motor drops. Clean the AC spindle motor by using the factory air and a vacuum cleaner.

2.2 AC Spindle Servo Unit

Since a cooling fan is mounted at the upper part of the servo unit, its nearby resistor and other parts become dusty after a long-time use. If they are dusty, clean them using the vacuum cleaner or the like.

2.3 Maintenance Tools

Use tools indicated in Table 2.3 (a) for adjustments and tools indicated in Table 2.3 (b) for repairing troubles.

Table 2.3 (a) Tools used for adjustments

Name	Specification	Use
AC voltmeter	1 - 300 V <u>+2%</u> or less	AC power voltage measurement
⊕, ⊖ screwdrivers	⊕ large, medium size ⊖ large, medium, small size	

Table 2.3 (b) Tools used for repairing troubles

Name	Specification	Use
AC voltmeter	1 - 300 V <u>+1%</u> or less	AC power voltage measurement
DC voltmeter	1 mV - 500 V <u>+1%</u> or less	DC power voltage measurement and offset voltage check
Circuit tester		Resistance value check
⊕, ⊖ screwdrivers	⊕ large, medium size ⊖ large, medium, small size	

2.4 Major Maintenance Parts

For maintenance parts, see appendix 7 Major maintenance parts.

3. TROUBLESHOOTING

Perform troubleshooting, referring to each item in Table 3 according to trouble conditions if a trouble occurred.

Table 3 Sort of trouble conditions

Item	Trouble conditions	Reference item
1	Power voltage check	3.1
2	Power ON indicator lamp PIL does not light.	3.2
3	Alarm (AL-□□) is displayed on the PCB.	3.3
4	Number of rotation is not as specified.	3.4
5	Motor does not rotate.	3.4
6	Vibrations and noises are noticeable during rotation.	3.5
7	An abnormal noise is produced from motor during deceleration.	3.6
8	Motor speed overshoots or hunting occurs.	3.7
9	Cutting power drop	3.8
10	Spindle orientation is not correct.	3.9
11	Acceleration/deceleration time is longer than specified.	3.10

Note) When replacing the spindle control PCB or the control PCB, follow the cautions described in section 6.2. Refer to Appendix 2.

3.1 Power Voltage Check

Check AC power voltage and DC power voltage on the spindle control PCB. Test points and standard values are as specified in Table 3.1.

Table 3.1 Power voltage check

AC power voltage check	Check at INPUT terminals R,S,T (See 4.2)		
DC power voltage check on the spindle control PCB	Voltage	Test points	Standard value
	+24 V	+24 V - 0 V	About 25 V <u>+4%</u>
	+15 V	+15 V - 0 V	+15 V <u>+4%</u>
	+5 V	+5 V - 0 V	+5 V <u>+2%</u>
	-15 V	-15 V - 0 V	-15 V <u>+4%</u>

Test points (refer to Appendix 6.)

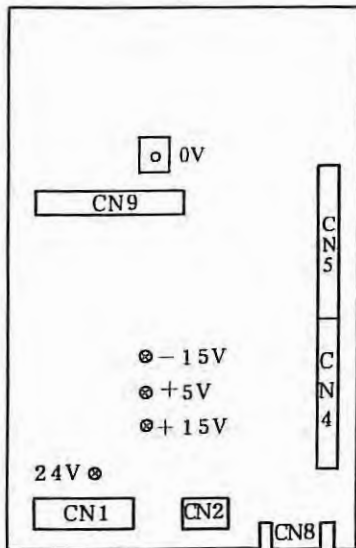

Spindle control PCB for models 1S - 3S

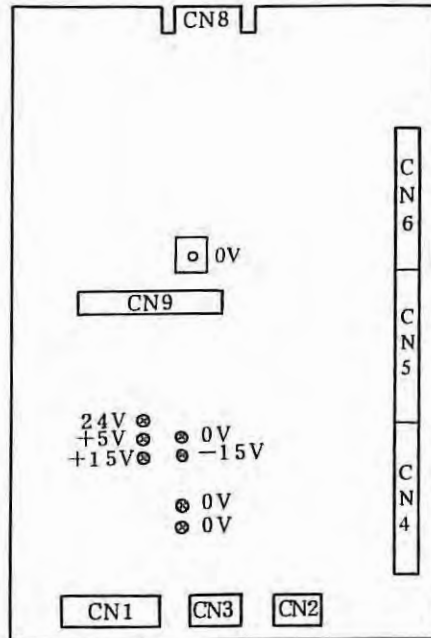

Spindle control PCB for models 6S - 22S

Note) Be careful that the 200 VAC is output on CN8 connector for models 1S - 3S and 300 VDC on CN8 for models 6S - 22S.

3.2 Power On Indicator Lamp PIL is not Lit

Table 3.2 Check procedure and remedy

Item	Causes	Check procedure	Remedy
1	AC power is not supplied.	Check it at power input terminals R,S,T.	
2	For models 6S - 22S, fuse FUR, FUS or FUT is blown.	See Appendix 5.	Replace fuse FUR, FUS or FUT.
3	For models 1S - 3S, fuse F1 or F2 is blown. For models 6S -22S, fuse F2 or F3 is blown.	Check if alarm indications of fuses F2 and F3 appear. See Appendix 5.	Check whether the pulse generator cable or position coder cable for orientation is open. Replace the fuse F1, F2 or F3. When the fuse is blown even if replacing it, replace the PCB.
4	PCB connectors are not plugged correctly. CN4, 5 : models 1S - 3S CN4 - 6: models 6S - 22S	Check if the connector guide groove appears on the PCB connector surface.	Insert connectors correctly. Refer to section 6.

Item	Causes	Check procedure	Remedy
5	PCB power circuit is defective.	Lamp PIL is lit by +5 V and -15 V. Check power voltage according to Table 3.1.	Replace PCB. Refer to section 6.

3.3 Alarm is Indicated

Alarms on AC spindle motor and servo unit are indicated on five digits of seven-segment on the servo unit PCB. Correspondence between seven-segment indications and alarm signals is shown in Table 3.3 (a), (b).

Table 3.3 (a) Alarm (models 1S - 3S)

Alarm No.	Meanings	Contents	Remedy
AL-01	Motor overheat	This lamp lights when internal temperature of motor is higher than the specified value.	Cool the motor and reset the alarm.
AL-02	Excessive deviation of speed	This lamp lights when the motor speed is largely deviated from the command speed.	Reset alarm.
AL-03	Defective regenerative current	Detects that regenerative current has flown longer than the allowable time.	Reset alarm after removing the problem.
AL-04		—	
AL-05		—	
AL-06	Overspeed (Analog detection)	This lamp lights when the motor exceeds 115% of the rated speed.	Reset alarm.
AL-07	Overspeed (Digital detection)	This lamp lights when the motor exceeds 115% of the rated speed.	Reset alarm.
AL-08	Overvoltage	This lamp lights when voltage largely exceeds the rated working voltage range due to a tap selection failure, etc.	Reset alarm.
AL-09		—	
AL-10	Detects lower voltage.	Detects the input power voltage lessened.	Remove the problem and reset the alarm.

Alarm No.	Meanings	Contents	Remedy
AL-11	Excessive high voltage of DC link	Detects over DC voltage of power.	Remove the problem and reset the alarm.
AL-12	Abnormal current of DC link Defective transistor	Detects over current of circuit.	Remove the problem and reset the alarm.
AL-13 - 15	—		
AL-16 - 23	Defective arithmetic circuit and peripheral circuit		
No indication	Defective ROM		

Table 3.3 (b) Alarm (models 6S - 22S)

Alarm No.	Meanings	Contents	Remedy
AL-01	Motor overheat	This lamp lights when internal temperature of motor is higher than the specified value.	Cool the motor and reset the alarm.
AL-02	Excessive deviation of speed	This lamp lights when the motor speed is largely deviated from the command speed.	Reset alarm.
AL-03	+24 V fuse is blown.	+24 V fuse of the control power is blown.	Replace a fuse and turn on the power again.
AL-04	Open phase of input power	A phase of input power is open.	Remove the problem and turn on the power again.
AL-05	—		
AL-06	Overspeed (Analog detection)	This lamp lights when the motor exceeds 115% of the rated speed.	Reset alarm.
AL-07	Overspeed (Digital detection)	This lamp lights when the motor exceeds 115% of the rated speed.	Reset alarm.
AL-08	Overvoltage	Voltage extremely excesses the rated voltage.	Reset alarm.

Alarm No.	Meanings	Contents	Remedy
AL-09	Overheat of radiator	Temperature of radiator such as semiconductor is extremely high.	Cool the radiator and reset an alarm.
AL-10	Lower voltage of input power	Detects lower voltage of input power.	Remove the problem and turn on the power again.
AL-11	Excessive high voltage of DC link	Detects over DC voltage of power.	Remove the problem and reset the alarm.
AL-12	Abnormal current of DC link Defective transistor	Detects over current of circuit.	Remove the problem and reset the alarm.
AL-13	Defective arithmetic circuit	Abnormal transmission between microcomputer and peripherals	Remove the problem and reset the alarm.
AL-14	Defective ROM	Detects defective ROM.	Replace ROM.
AL-15	Defective optional circuit	Detects defective optional circuit and erroneous connection to optional circuit.	Remove the problem and reset the alarm.

1) Alarm No. 01 (AL-01) Motor is overheated.

Item	Causes	Check	Remedy
1	Built-in fan motor of spindle motor is defective.		Replace fan motor.
2	Overload operation	Check it using a load meter.	Re-examine cutting conditions and tools.
3	Motor cooling system is dirty.		Clean it using compressed air or vacuum cleaner.
4	Disconnection or poor contact of wiring	Check connections between motor and servo unit.	Confirm the connection of connector for signal. (Note)

Note) Refer to Appendix 2.

2) Alarm No. 02 (AL-02) Speed is deviated from the command value.

Item	Causes	Check	Remedy
1	Overload	Check it using a load meter.	Re-examine cutting conditions and tools.
2	Transistor module is defective.	Transistor collector-emitter is open.	Replace transistor module. (Note 1)
3	Blow out or poor connection of the driver protective fuse on PCB.	Check fuses F4A - F4M for blown out or missing.	Connect fuses securely, and replace blown out fuses, if any.
4	Speed feedback signal is defective.	Check the speed feedback signal level. (Note 2)	Check the motor speed detector or signal cable.
5	Wiring failure (disconnection, poor contact, etc.)	Check if connection cables are normally connected.	

Note 1) Refer to section 6.4.

Note 2) Speed feedback signal check

Observe the speed feedback signal using an oscilloscope under the rotation command off (motor stop, drive power off) condition after turning on the power supply. Observe it at the following check terminals, while slowly turning the motor by hand.

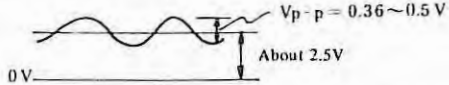
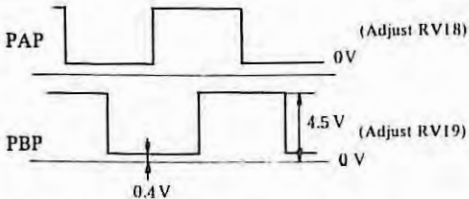
Test points	Normal waveforms
PA-0V	 <p>$V_{p-p} = 0.36 \sim 0.5 V$ About 2.5V 0V</p>
PB-0V	Same as shown above
RA-0V	2.5 \pm 0.2 VDC
RB-0V	Same as shown above
PAP-0V PBP-0V (CW rotation)	 <p>PAP (Adjust RV18) 0V 0.4V PBP (Adjust RV19) 4.5V 0V</p> <p>Check within ON/OFF duty is 50%.</p> <p>(PAP and PBP signals are inverted in CCW direction.)</p>

3) Alarm No. 03 (AL-03)

- Models 1S - 3S: Defective regenerative circuit

Item	Causes	Check	Remedy
1	Transistor TR1 on the regenerative circuit is defective.	Check collector (C), emitter (E) and base (B) of transistor. Refer to section 6.4.	Replace transistor TR1.

- Models 6S - 22S: +24 fuse is blown.

Item	Causes	Check	Remedy
1	Fuse F1 on PCB is blown.		Replace fuse F1.

4) Alarm No. 04 (AL-04) Open phase of input power (models 6S - 22S)

Item	Causes	Check	Remedy
1	High impedance on AC power supply side. (Example) Two transformers are connected in series or when a variable auto-transformer is connected.	- Alarm AL-04 lights only when the motor speed is reduced from high speed.	- Replace the power supply having low power impedance. (Note 1) - Looseness of input cable connector. Example: Open phase due to loosened screws.
2	Transistor module is defective.		Replace transistor module. (Note 2)
3	MCC or AC reactor is defective. Detection resistor R5 or R6 is open.		Replace the defective part.

Note 1) Power impedance checking method.

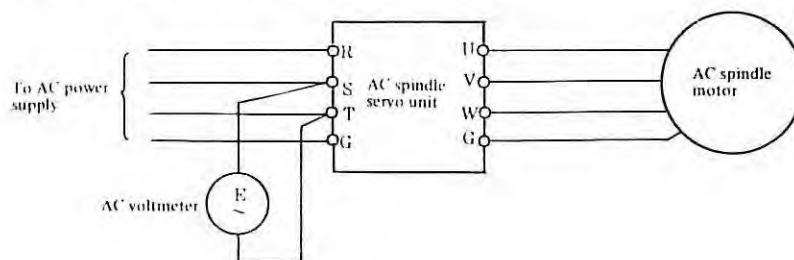

Calculation formula

$$\frac{E0 - E1}{E0} \times 100 (\%) < 7 (\%)$$

where E0: Voltage when the motor stops operating.

E1: Voltage during acceleration of motor or voltage just before the motor speed begins lowering with a load applied.

Input power specifications

Name	Specifications
Nominal rated voltage	200/220/230 VAC
Allowable voltage fluctuation width	-15% - +10%
Power frequency	50/60 Hz
Power impedance	Voltage fluctuation due to load (120% load at 30 minute rating): Less than 7%

Note 2) Refer to section 6.

5) Alarm No. 06 (AL-06) Overspeed (analog detection)

Item	Causes	Check	Remedy
1	PCB setting failure or adjusting failure	Check PCB for normal setting and adjustment.	Change setting of PCB. Confirm parameter F-5.
2	Wrong specification of ROM (memory IC)	Check specification referring to Table 1.2 (a).	Replace ROM.
3	PCB is defective.		Replace PCB. Refer to section 6.

6) Alarm No. 07 (AL-07) Overspeed (digital detection)

Same as in alarm No. 06 (AL-06).

7) Alarm No. 08 (AL-08) Overvoltage

Item	Causes	Check	Remedy
1	AC power voltage exceeds the rated value.	Check power voltage.	Stabilize the input voltage.

8) Alarm No. 09 (AL-09) Radiator is overheated. (models 6S - 22S)

Item	Causes	Check	Remedy
1	Cooling fan is defective.	Check if fan is stopping.	Replace fan.
2	Overload operation.	Check load by using a load meter.	Re-examine the cutting condition.
3	Dusty and dirty.		Clean using compressed air or vacuum cleaner.

9) Alarm No. 10 (AL-10) Input power voltage drops.

This alarm indicates abnormally low AC power voltage (-15% or less).

10) Alarm No. 11 (AL-11) Overvoltage of DC link circuit.

(Regenerative circuit is faulty ... Regeneration failure)

Item	Causes	Check	Remedy
1	High power impedance.		Examine AC power specification. Refer to section 4.2.
2	PCB is defective.		Replace PCB. (Note)
3	Defective transistor module (TM1).		Replace transistor module. (Note)
4	Resistor R10 is open.		Repair resistor R10.

Note) Refer to section 6.

11) Alarm No. 12 (AL-12) Overcurrent flows to DC link circuit.

Item	Causes	Check	Remedy
1	Output terminals or internal circuit of motor is shorted.	Check connections.	
2	Transistor module is defective.	Check the transistor module.	Replace transistor module. (Note)
3	PCB is defective.		Replace PCB. (Note)

Note) Refer to sections 6.2 - 6.4.

12) Alarm No. 13 (AL-13) CPU alarm. (models 6S - 22S)

Replace PCB. Refer to section 6.

13) Alarm No. 14 (AL-14) ROM is defective. (models 6S - 22S)

Item	Causes	Check	Remedy
1	ROM is not mounted at all or not properly mounted.	Check if ROM is unplugged from the socket or if its leads are broken.	Mount ROM properly.
2	ROM is defective.	Check series No. of ROM.	Replace ROM having correct specification. See Table 1.2 (a).

14) Alarm No. 15 (AL-15) Defective optional circuit (models 6S - 22S)

Item	Causes	Check	Remedy
1	Defective optional PCB		Replace PCB. (Note) Refer to section 6.3.
2	Optional PCB connection is improper.		Check and correct the connection. Refer to Appendix 1.

3.4 Motor does not Rotate or its Rotation is Abnormal

Item	Causes	Check procedure	Remedy
1	Defective phases of motor power line	Alarm lamp lights on spindle servo unit when rotation command is given.	Repair phases. Refer to Appendix 2.
		Alarm lamp does not light.	Apply higher voltage of speed command.
2	Command signal connection failure	Check signal cable Connection.	
3	Parameter is not proper.		Set parameters F-01 and F-02 correctly. Refer to section 5.4.
4	ROM is not proper.	Check series No. of ROM. See Table 1.2 (a).	Set ROM correctly.

3.5 Vibration or Noise is too Large during Rotation

Item	Causes	Check procedure	Remedy
1	Motor is defective.		Replace motor.
2	PCB is defective.	Run the motor idly. When the connector CN2 from AC spindle servo unit while rotating the motor, overheat alarm (AL-01) occurs, and the motor runs idly. (Note) If vibrations and noises are reduced during idle run as compared with normal rotation time, the control circuit is defective.	Replace PCB. Refer to section 6.

Note) To perform idle run contact with the MTB whether idle run is considered. Some of sequences makes brake enable.

3.6 Noise is Produced from Motor during Deceleration

During deceleration of the motor, energy is regenerated to the power supply through the regenerative control circuit. If the regenerative energy is excessive, the regenerative current limit circuit operates to change the motor current waveform, causing an abnormal noise to be produced from the motor. In such a case, lessen parameter F-20 until no abnormal noise is produced. Lessening F-20 makes the deceleration period long.

3.7 Speed Overshooting or Hunting Occurs

Item	Causes	Check procedure	Remedy
1	Overshooting	Enlarge F-21 or F-22. (Note)	Readjust. Refer to section 5.4.
2	Spindle hunting	Lessen F-21 or F-22. (Note)	Readjust. Refer to section 5.4.

Note) Adjust F-21 for "HIGH" clutch, and F-22 for "LOW" clutch.

3.8 Cutting Force is Low

Item	Causes	Check procedure	Remedy
1	ROM is not proper.	Check it referring to Table 1.2 (a).	Replace ROM.
2	Torque limit command is applied.	Check signal.	
3	Loosened belt	Check belt tension.	

3.9 Orientation is not Correct

Item	Causes	Check procedure	Remedy
1	Setting or adjusting failure of orientation control circuit.	Check if circuit is set and adjusted as specified in data sheet.	Refer to section 7.
2	Orientation control circuit PCB is defective.		Replace PCB. Refer to section 6.
3	Spindle control PCB is not adjusted properly.	Adjust deceleration time of spindle control circuit. Adjust parameter F-20 to shorten the deceleration period.	Adjust PCB. Refer to section 7.
4	Position detection (position coder or magnetic sensor) is defective.	Check the output signal waveform of the position detector.	Replace the position coder or magnetic sensor.

3.10 Acceleration/Deceleration Time is Long

Item	Causes	Check procedure	Remedy
1	Torque limit command is applied.	Check signal.	
2	Defective receiver part activates the torque limit.	Change torque limit parameter F18 to adjust acceleration period.	Replace receiver part (HY2) or PCB.
3	PCB is not adjusted correctly.	If parameter F-20 is set too low, the deceleration period becomes long. Refer to section 3.6.	Readjust F-20. Refer to section 5.4.

4. INSTALLATION

4.1 Installation Procedure

Observe the checking procedure shown in Table 4.1 at the installation.

Table 4.1 Installation procedures

Item	Description	Remarks
1	Check if specifications of motor, servo unit, options, etc. are correct.	Check if motor corresponds to units, PCB, and ROM correctly according to Table 1.2.
2	Check appearance for damage	Check resistors, and parts on the PCB.
3	Check the working AC power supply for voltage, voltage fluctuation, power capacity (kVA) and frequency.	See Table 4.2.1.
4	Connect the earth wire, power cable and drive power cable.	Refer to sections 4.2, 4.3, 4.4 and Appendix 1.
5	Check setting and adjustment results.	Refer to section 5.1.
6	Turn on AC power supply, and make sure that green lamp P1L lights on PCB.	Refer to Appendix 6.
7	Give rotation command to check the normal rotation and reverse rotation movement.	
8	Check the operation over the entire velocity range.	
9	Adjust spindle orientation circuit.	Refer to section 7.

4.2 Power Connection

4.2.1 Power voltage and capacity check

Measure the AC power voltage before connecting the power supply, and take the following measure according to power voltage.

Table 4.2.1 (a) Checking AC power voltage

AC power voltage	Nominal voltage	Measures
170 - 253 VAC		Connect directly.
Higher than 254 VAC	380 V to 550 V	Set input voltage to 200 VAC using insulation transformer.

The input power specification of the AC spindle servo unit is as specified in Table 4.2.1 (b). Use a power source having the power capacity having a sufficient allowance so that no trouble due to voltage drop occurs with the maximum load.

Table 4.2.1 (b) Input power specification of AC spindle servo unit

Nominal rated voltage		200/220/230 VAC, 3 phases											
Allowable voltage fluctuation		-15% to +10%											
Frequency		50 Hz/60Hz \pm 1 Hz											
Power capacity	Motor model	1S	1.5S	2S	3S	6S/A3	6S	8S	12S/A8	12S	15S	18S	22S
	Capacity with 30-minute rating (kVA)	4	7	7	9	9	12	17	17	22	26	32	37

4.2.2 Protective earth connection

Connect the protective earth to connection terminal G before connecting the power supply. Use the protective earth having sufficient capacity as compared with the feeder circuit breaker capacity.

4.2.3 Power connection

Connect the power cable after protective earth connection.

The power phase rotation is not specified for AC spindle servo unit.

The cooling fan motor employs three-phase power. When connect the input power to the unit, check the proper phase connection.

4.3 AC Spindle Motor Connection

Connect the AC spindle motor according to the connection diagram in Appendix 1. If the drive power cable connection sequence is in error, vibration are produced the motor does not rotate or alarm (AL-02) occurs to stop the motor. Always connect protective earth "G".

4.4 Single Cable Connection

Connect the signal cable according to the connection diagram in Appendix 1.

5. SETTING AND ADJUSTING

5.1 Jumper and Variable Resistor on Spindle Control PCB (models 1S - 3S)

Refer to Appendices 5 and 6 for part locations of the unit and PCB. Always confirm the location of parts on PCB before power on.

Table 5.1 (a) Jumpers (models 1S - 3S)

Jumper	Contents	State			Setting at shipment
		Test mode	TEST	DRIVE	
S1	Switches mode of control circuit	Operation mode	DRIVE		DRIVE
S2 S3	Selects from right table according to the speed at rated command (VCMD = 10 V) Detector I: Gear of 256 teeth Detector II: Gear of 128 teeth	Detector I (rpm)	Detector II (rpm)		Depends upon model.
			6000	D	
		4500	8000	C	
		6000	10000 to 12000	B	
		8000 to 10000	15000 to 20000	A	
S4 S5	Switches gain	Normal operation mode	OFF		OFF
		Switches gain	ON		

Table 5.1 (b) Variable resistor (models 1S - 3S)

Variable resistor	Contents	Setting at shipment		
RV1	Maximum speed in CCW direction	Depends upon model.		
RV2	Maximum speed in CW direction			
RV3	Offset of speed detection circuit	Adjust TS3 to 0 mV \pm 0.1 mV at rotation command OFF.		
RV4	Voltage of +5 V	+5 V \pm 0.1 V		
RV5	Adjusts gain at switching of gain	50%		
RV6	Gain of speed detection circuit for low speed	Model	Value (rpm)	Max. speed (rpm)
	Adjusts speed at 25 mV \pm 2 mV of VCMD for each model	3S	15 \pm 3	6000
		1S, 1.5S, 2S	20 \pm 4	8000

5.2 Jumper on Spindle Control Circuit (models 6S - 22S)

Refer to Appendices 5 and 6 for parts location of the unit and PCB. Always confirm the location of parts on PCB before power on.

Table 5.2 Jumpers (models 6S - 22S)

Jumper	Contents	Position	Setting at shipment
S1	Drive mode	DRIVE	DRIVE
	Test mode	TEST	
S2	Increases 10% of power voltage of +5 V	+10	No setting
	Decreases 10% of power voltage of +5 V	-10	
S5	MOFF1 (CN3 - 15) and MOFF2 (CN3 - 16) signals are used.	EXT	INT
	MOFF1 and MOFF2 signals are not used.	INT	
S6	Option setting	S6A: ON +24 V S6B: ON +5 V S6C: ON -15 V OFF: Not apply	Optional setting is not set. OFF

5.3 Parameter Setting Method

The setting switch and the display part are arranged on the PCB like the figure below. Refer to Appendix 6.

These switches enable to confirm and set parameters.

Display part



Setting switch

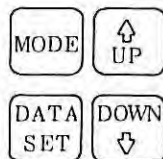

- 1) To confirm the current parameter
 - a) The speed is usually displayed at the display part (Five digits). The current parameter number can be displayed when "MODE" is on. The parameter number is displayed as two digits of "F-XX".

- 2) To confirm the setting data
 - a) Select the parameter number of data to be checked in the following manner.
 - b) Continuously turn 4 switches "MODE", "↑ UP", "↓ DOWN" and "DATA SET" ON at the same time for more than one second.
 - c) The display part changes from the blank to "FFFFFF".
 - d) Off all switches.
 - e) The current parameter is displayed when "MODE" is on.
 - f) When "↑ UP" is on with "MODE" on, the parameter number is incremented by 1.
 - g) When "↑ UP" is continuously on with "MODE" on, the parameter number increases continuously.
 - h) When "↓ DOWN" is on with "MODE" on, the parameter number is decremented by 1.
 - i) When "↓ DOWN" is continuously on with "MODE" on, the parameter number decrements continuously.
 - j) With "MODE" off, the data is displayed (4 digits) after approx. 0.5 second.
 - k) After approx. 10 seconds the data display is selected, the speed display is selected. When all switches are off in any mode, the speed is finally displayed.
- 3) To alter the data
 - a) Select the parameter to be changed according to the steps (2)-(b) to (i).
 - b) Turn "MODE" off: The data of parameter is displayed after approx. 0.5 second.
 - c) Turn "↑ UP" on: The data is incremented by 1.
 - d) Turn "↑ UP" on continuously: The data is incremented continuously.
 - e) Turn "↓ DOWN" on: The data is decremented by 1.
 - f) Turn "↓ DOWN" on continuously: The data is decremented continuously.
 - g) The motor is controlled using the displayed data.
 - h) When replacing the data with the modified data, keep turning "DATA SET" on for one second or more.
 - i) The display part changes from the blank to "88888" and modification of the data completes.
 - j) When changing the data once again, follow the steps from (3)-(a) above.
 - k) The speed is indicated automatically after about 10 seconds. For parameters F-13, F-14 and F30, speed is displayed after 2 seconds.

5.4 Number and Content of Parameter

1) Motor speed indication

Parameter No.	Display data (Five digits)	Contents of data
F-00		The speed of the motor is displayed. (rpm)

2) Use/no use of the machine ready signal (MRDY)

Parameter No.	Display data (Five digits)	Contents of data
F-01	0001	0, 1 (Standard setting: 0)

Explanation: Machine ready signal (MRDY) is used : 1
 Machine ready signal (MRDY) is not used: 0

3) Use/no use of speed override (models 6S - 22S)

Parameter No.	Display data (Four digits)	Contents of data
F-02	0001	0, 1 (Standard setting: 1)

Explanation: Use speed override : 1
Not use speed override: 0

4) Range of speed override (models 6S - 22S)

Parameter No.	Display data (Four digits)	Contents of data
F-03	0001	0, 1 (Standard setting: 1)

Explanation: Upper limit of speed override (up to 120%): 1
Upper limit of speed override (up to 100%): 0

Note) When F-02 is set to 0; speed override is not used, F-03 should be set to 0.

5) Maximum speed (models 6S - 22S)

Parameter No.	Display data (Four digits)	Contents of data
F-05		0 - 3 (Depend upon motor)

Explanation:

6S - 22S (rpm)	1S - 3S (rpm)	Setting
Up to 5000	Up to 10000	0
Up to 6000	Up to 12000	1
	Up to 15000	2
	Up to 20000	3

6) Output limit pattern

Parameter No.	Display data (Four digits)	Contents of data
F-06	0000	0 to 6 (Standard setting: 0)

Explanation: This function is not available for a conventional type.
In the following cases, select a pattern which is appropriate respectively.

- A. When the output is limited only at acceleration and deceleration, the motor accelerates and decelerates slowly, and operates at the rated output during steady rotation (Setting data: 1 or 4) (function similar to software start and stop)
- B. When the motor accelerates and decelerates at the maximum rated output and the output is limited during stable rotation (Setting data: 2 or 5)

C. When the same motor and amplifier are used to operate the machine as a different output specification machine (Setting data: 3 or 6)

Content	Setting data	
	Pattern 1	Pattern 2
The output is not limited.	0	0
Output is limited only at acceleration and deceleration.	1	4
No output is limited at acceleration and deceleration but it is limited during steady rotation.	2	5
The output is limited over all movements.	3	6

(Output limit pattern 1): The setting data = 1, 2, 3

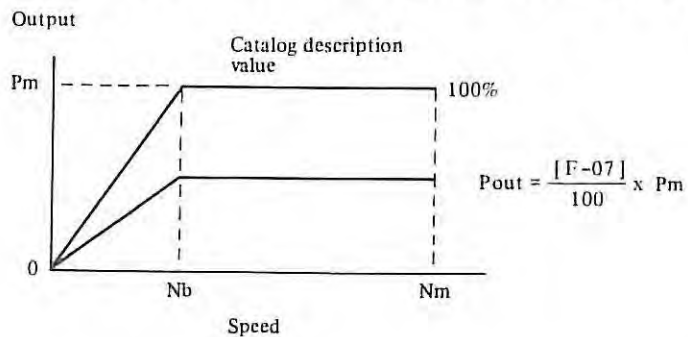

(Output limit pattern 2): The setting data = 4, 5, 6

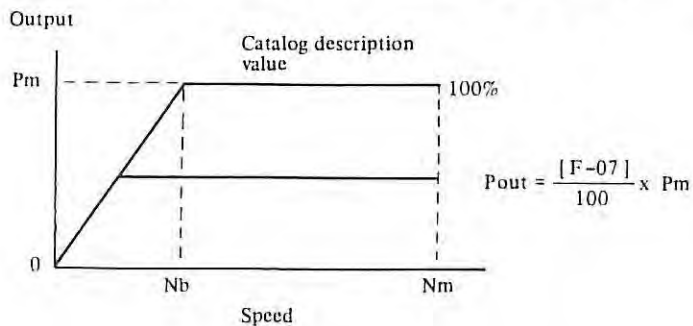

7) Limit value at output limited

Parameter No.	Display data (Four digits)	Contents of data
F-07	0100	0 to 100 (Standard setting: 100)

Explanation: With the maximum rated output (overload capacity) as 100%, set the limit value to a value to be limited. This value is available when the output is limited due to parameter F-06.

Output limit value = Maximum rated output x (setting data) %

8) Delay time to motor power interruption

Parameter No.	Display data (Four digits)	Contents of data
F-08	0005	0 to 255 (Standard setting: 5)

Explanation: Delay time from zero speed signal detection to the motor power interruption.

$$\text{Delay time} = (\text{Setting data}) \times 40 \text{ msec}$$

9) Use/no use of excitation interruption of motor power using machine ready signal (MRDY)

Parameter No.	Display data (Four digits)	Contents of data
F-09	0000	0, 1 (Standard setting: 0)

Explanation: The function is used when it is presumed that the electromagnetic contactor is switched frequently. When the machine ready signal (MRDY) is off, only motor power is interrupted, and the electromagnetic contactor remains on.

The function is used : 1

The function is not used: 0

10) Adjustment of speed error offset at the time of the forward rotation command (SFR)

Parameter No.	Display data (Four digits)	Contents of data
F-10	0128	0 - 255 (Standard setting: 128)

Explanation: The speed error offset is adjusted when stopping motor with the forward rotation command (SFR) and speed command voltage 0 V (zero rotation command) applied. Increase the data when stopping the motor rotating counterclockwise (CCW), as viewed from the shaft.

11) Adjustment of speed error offset at the time of the reverse rotation command (SRV)

Parameter No.	Display data (Four digits)	Contents of data
F-11	0128	0 - 255 (Standard setting: 128)

Explanation: The speed error offset is adjusted when stopping motor with the reverse rotation command (SRV) and speed command voltage 0 V (zero rotation command) applied. Increase the data when stopping the motor rotating CCW, as viewed from the shaft.

- 12) Adjustment of speed error offset at the time of the orientation command (ORCM)

Parameter No.	Display data (Four digits)	Contents of data
F-12	0128	0 - 255 (Standard setting: 128)

Explanation: The parameter is used for adjustment when no adjustment is possible so that the LED of IN-POSITION FINE is lit at orientation using the variable resistor on the orientation circuit.

- 13) Speed at forward rotation command (SFR)

Parameter No.	Display data (Four digits)	Contents of data
F-13		0 - 255 (Depends upon motor)

Explanation: Adjust the speed when inputting specific speed command at forward rotation command (SFR). Increase data to increase speed.

- 14) Speed at reverse rotation command (SRV)

Parameter No.	Display data (Four digits)	Contents of data
F-14		0 - 255 (Depends upon motor)

Explanation: Adjust the speed when inputting specific speed command at reverse rotation command (SRR). Increase data to increase speed.

- 15) Speed when speed command voltage is 10 V

Parameter No.	Display data (Four digits)	Contents of data
F-15		0 - Rated speed (Depends upon motor)

Explanation: When making adjustments in sections (14) and (15), always set this mode. Set the value of speed at 10 V speed command voltage divided by 100.

$$\text{Speed at 10 V speed command voltage (rpm)} = (\text{Setting data}) \times 100$$

16) Detection range of speed arrival signal (SAR)

Parameter No.	Display data (Four digits)	Contents of data
F-16	0015	0 - 100 (Standard setting: 15)

Explanation: Sets the detection range of the speed arrival signal (SAR).
The speed arrival signal (SAR) is outputted when the motor speed reaches the range within specific percentage of the command speed.

$$\text{Detection range} = (\text{Command speed}) \times (\pm (\text{Setting data})) \%$$

17) Detection range of speed detecting signal (SDT)

Parameter No.	Display data (Four digits)	Contents of data
F-17	0003	0 - 100 (Standard setting: 3)

Explanation: The detection range of the speed detecting signal (SDT) is set.
The speed detecting signal (SDT) is outputted when the motor speed becomes the specific percentage of a maximum speed or less.

$$\text{Detection range} = (\text{Maximum speed}) \times (\text{Setting data}) \%$$

18) Setting of torque limit value

Parameter No.	Display data (Four digits)	Contents of data
F-18	0050	0 - 100 (Standard setting: 50)

Explanation: When the torque limit signal (TLMH) is turned on, torque limit value is set.

$$\text{Torque limit value} = (\text{Maximum rated torque}) \times (\text{Setting data}) \%$$

19) Acceleration/deceleration time

Parameter No.	Display data (Four digits)	Contents of data
F-19	0010	0 - 255 (Standard setting: 10)

Explanation: Set this parameter when the acceleration time from the stop to the maximum speed is longer than 5 seconds.

$$\text{Setting value} = (\text{Acceleration time, sec}) \times 2$$

20) Limit of regenerative power (Adjustment of deceleration time)

Parameter No.	Display data (Four digits)	Contents of data
F-20	0040	0 - 100 (Standard setting: 40)

Explanation: Adjust the deceleration time to the same as the acceleration time.
 The deceleration time shortens when the setting value increases.
 The deceleration time lengthens when the setting value decreases.
 However, when the regenerative power is excessive, the regenerative limit circuit is actuated and the motor current waveform changes; therefore, abnormal noise may be produced from the motor. In this case, this abnormal noise is suppressed by decreasing the setting value.

21) Speed control phase compensation P: HIGH gear (CTH = 1)

Parameter No.	Display data (Four digits)	Contents of data
F-21	0050	0 - 255 (Standard setting: 50)

22) Speed control phase compensation P: LOW gear (CTH = 0)

Parameter No.	Display data (Four digits)	Contents of data
F-22	0050	0 - 255 (Standard setting: 50)

23) Speed control phase compensation P in orientation: HIGH gear (CTH = 1)

Parameter No.	Display data (Four digits)	Contents of data
F-23	0100	0 - 255 (Standard setting: 100)

24) Speed control phase compensation P in orientation: LOW gear (CTH = 0)

Parameter No.	Display data (Four digits)	Contents of data
F-24	0100	0 - 255 (Standard setting: 100)

25) Speed control phase compensation I: HIGH gear (CTH = 1)

Parameter No.	Display data (Four digits)	Contents of data
F-25	0030	0 - 255 (Standard setting: 30)

26) Speed control phase compensation I: LOW gear (CTH = 0)

Parameter No.	Display data (Four digits)	Contents of data
F-26	0030	0 - 255 (Standard setting: 30)

27) Speed control phase compensation I in orientation: HIGH gear (CTH = 1)

Parameter No.	Display data (Four digits)	Contents of data
F-27	0030	0 - 255 (Standard setting: 30)

28) Speed control phase compensation I in orientation: LOW gear (CTH = 0)

Parameter No.	Display data (Four digits)	Contents of data
F-28	0030	0 - 255 (Standard setting: 30)

29) Speed detection offset (models 6S - 22S)

Note) Refer to paragraph of speed offset adjustment for models 1S - 3S.

Parameter No.	Display data (Four digits)	Contents of data
F-29	0128	0 - 255 (Setting at shipment: approx. 128)

Explanation: Adjust this parameter so that the test pin TS3 will be 0 mV at motor stopping.

30) Rigid tap mode

Parameter No.	Display data (Four digits)	Contents of data
F-31	0000	0 - 1 (Standard setting: 0)

Explanation: The torque limit signal (TLML) is used to a conventional torque limit: 0
 The torque limit signal (TLML) is used for motor voltage switching when improved transient response characteristics are required for rigid tapping operation: 1

31) Motor voltage at normal operation

Parameter No.	Display data (Four digits)	Contents of data
F-32	0010	0 - 100 (Standard setting: 10)

32) Motor voltage in orientation

Parameter No.	Display data (Four digits)	Contents of data
F-33	0010	0 - 100 (Standard setting: 10)

33) Motor voltage in rigid tap mode

Parameter No.	Display data (Four digits)	Contents of data
F-34	0100	0 - 100 (Standard setting: 100)

Explanation: This parameter is effective when data of F-31 is 1.

34) Detection range of zero-speed detection signal

Parameter No.	Display data (Four digits)	Contents of data
F-35		0 - 255 (Standard setting: 75)

Explanation: The zero-speed signal is used as the completion signal for stop command.

This signal is detected when the speed of the motor becomes (The setting data/100)% of a maximum speed or less.

$$\text{The detection range} = (\text{maximum speed}) \times (\text{The setting data}/100)\%$$

35) Detection range of load detection signal

Parameter No.	Display data (Four digits)	Contents of data
F-36		0 - 100 (Standard setting: 90)

Explanation: The load is detected when the load becomes greater than the specific percentage of maximum detection level of the load meter.

$$\text{Detection level} = (\text{maximum detection level of load meter, 10}) \times (\text{setting data})\% \text{ or more}$$

36) Time constant of torque deviation at deceleration start (models 6S - 22S)

Parameter No.	Display data (Four digits)	Contents of data
F-37	0000	0 - 3 (Standard setting: 0)

Explanation: Use this parameter when the gear noises at deceleration in low speed rotation (base speed) due to the backlash of the spindle.

Data	Time constant (msec)
0 :	0
1 :	50
2 :	100
3 :	150

Set the data to 2 when the gear noises.

37) Characteristics of control in deceleration (models 6S - 22S)

Parameter No.	Display data (Four digits)	Contents of data
F-38	0000	0, 1 (Standard setting: 0)

Explanation: Use this parameter when the gear noises at deceleration in high speed rotation. Set the data to 1 to slow down the deceleration rate.

38) Characteristics of control in stable rotation with no load (models 6S - 22S)

Parameter No.	Display data (Four digits)	Contents of data
F-39	0000	0, 1 (Standard setting: 0)

Explanation: The motor speed may undulate in the stable rotation when setting the motor voltage (F-32) greater than the standard value (10). Set F-39 to 1 to reduce the motor undulation.

39) Characteristics of control in torque limitation (models 6S - 22S)

Parameter No.	Display data (Four digits)	Contents of data
F-40	0000	0, 1 (Standard setting: 0)

Explanation: The motor speed may overshoot due to the timing of the torque limit signal when making the torque limit in mechanical orientation. Set F-40 to 1 to reduce the overshoot of the speed.

5.5 Setting Rank (models 1S - 3S)

- Rank A (always setting)

Parameter No.	Contents
F-01	Use/no-use of the machine ready signal

- Rank B (special setting)

Parameter No.	Contents
F-16	Range of detecting the speed arrival signal
F-17	Level of detecting the speed detection signal
F-35	Level of detecting the zero-speed signal
F-18	Torque limit value
F-06, 07	Output limit
F-19	Period of acceleration/deceleration
F-20	Limit of regenerative power (deceleration time)
F-09	Use/no-use of motor power off using the machine ready signal
F-36	Level of detecting the load

5.6 Setting Rank (models 6S - 22S)

Parameters in only rank A are checked and changed by the MTB.

When changing the operating conditions (change of speed and special setting), the machine tool builder should divide the rank for use.

Pay attention not to alter the setting value by mistake.

- Rank A (always setting)

Parameter No.	Contents
F-01	Use/no-use of machine ready signal
F-02	Use/no-use of speed override
F-03	Range of speed override

- Rank B (changing the speed)

Parameter No.	Contents
F-13	Speed in forward direction
F-14	Speed in reverse direction
F-15	Speed at maximum speed command voltage (10 V)

- Rank C (special setting)

Parameter No.	Contents
F-16	Range of detecting the speed arrival signal
F-17	Level of detecting the speed detection signal
F-18	Torque limit value
F-19	Period of acceleration/deceleration
F-20	Limit of regenerative power (deceleration time)
F-09	Use/no-use of motor power off using the machine ready signal

5.7 Setting and Adjusting Spindle Orientation Control Circuit (option)

Refer to section "Spindle orientation control circuit."

6. REPLACING FUSE AND PCB

6.1 Replacing Fuse

Refer to Appendices 5 and 6 for the spindle control circuit PCB and fuses on the control circuit.

6.2 Replacing Spindle Control Circuit and Control Circuit PCB

Refer to Appendix 2.

Steps	Contents
1	Turn off the breaker on the magnetics cabinet to off the AC input power, and then remove the motor power line.
2	Remove the spindle control circuit PCB by pushing ten PCB holders outward. Replace the PCB with new one.
3	Remove screws other than that mounting electronic parts from the control PCB, and then remove the PCB. Refer to Appendix 2. Replace the PCB and/or transistor modules if necessary. Refer to section 6.4. Confirm screws to be bolted.

Note) Always confirm the voltage between plus and minus terminals of capacitor C1 is less than 60 VDC using a tester before handling the control circuit.

6.3 Replacing Spindle Orientation Control Circuit PCB

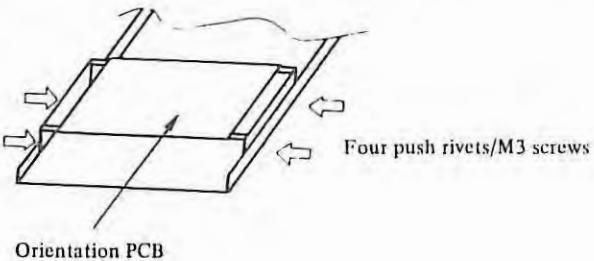
Steps	Contents
1	Turn off the breaker on the magnetics cabinet to off the AC input power, and then remove the motor power line.
2	Remove the spindle control unit PCB and then cables from PCBs.
3	Remove four push rivets or M3 screws from the plates mounting the PCB. 

Remount the PCB reversing the above procedures.

6.4 Replacing Transistor Module

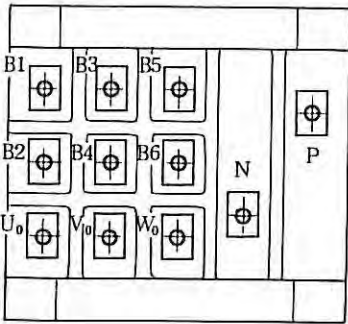
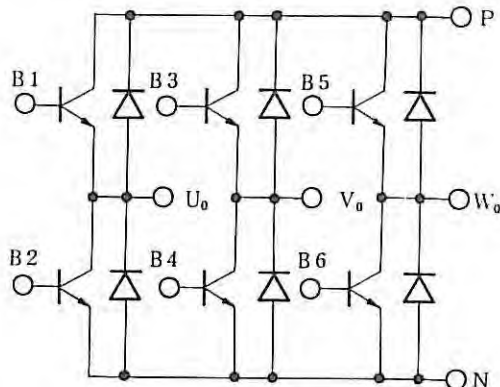
Steps	Contents																									
1	Turn off the breaker on the magnetics cabinet to off the AC input power, and then remove the motor power line.																									
2	<p>Check resistance of transistor modules on the lower control circuit PCB using a tester. Refer to Appendix 6.</p> <ol style="list-style-type: none"> 1. ⊕ (collector) - U, V, W (emitter) 2. U, V, W (collector) - ⊖ (emitter) 3. ⊕ (collector) - B1, B3, B5 (base) 4. U, V, W (collector) - B2, B4, B6 (base) 5. B1, B3, B5 (base) - U, V, W (emitter) 6. B2, B4, B6 (base) - ⊖ (emitter) <div style="display: flex; justify-content: space-around; align-items: center;">   </div> <p>Judgment (Range of tester: x 10 ohm)</p> <table border="1" data-bbox="282 1134 1207 1564"> <thead> <tr> <th>Terminal</th> <th>Tester</th> <th>Normal</th> <th>Abnormal</th> </tr> </thead> <tbody> <tr> <td rowspan="2">C - E</td> <td>C: +</td> <td>500 - 600 ohms</td> <td>Short, infinity</td> </tr> <tr> <td>C: -</td> <td>Infinity</td> <td>Short, 500 - 600 ohms</td> </tr> <tr> <td rowspan="2">C - B</td> <td>C: +</td> <td>500 - 600 ohms</td> <td>Short, infinity</td> </tr> <tr> <td>C: -</td> <td>Infinity</td> <td>Short, 500 - 600 ohms</td> </tr> <tr> <td rowspan="2">B - E</td> <td>B: +</td> <td>500 - 600 ohms</td> <td>Short, infinity</td> </tr> <tr> <td>B: -</td> <td>500 - 600 ohms</td> <td>Short, infinity</td> </tr> </tbody> </table> <p>When a transistor is defective, terminals between collector and emitter, and between collector and base are short.</p>	Terminal	Tester	Normal	Abnormal	C - E	C: +	500 - 600 ohms	Short, infinity	C: -	Infinity	Short, 500 - 600 ohms	C - B	C: +	500 - 600 ohms	Short, infinity	C: -	Infinity	Short, 500 - 600 ohms	B - E	B: +	500 - 600 ohms	Short, infinity	B: -	500 - 600 ohms	Short, infinity
Terminal	Tester	Normal	Abnormal																							
C - E	C: +	500 - 600 ohms	Short, infinity																							
	C: -	Infinity	Short, 500 - 600 ohms																							
C - B	C: +	500 - 600 ohms	Short, infinity																							
	C: -	Infinity	Short, 500 - 600 ohms																							
B - E	B: +	500 - 600 ohms	Short, infinity																							
	B: -	500 - 600 ohms	Short, infinity																							
3	Remove the lower control circuit PCB and replace it with new one. Apply thin silicon grease. Silicon grease: A98L-0001-0653																									
4	Remount the lower PCB. Firmly bolt all screws.																									

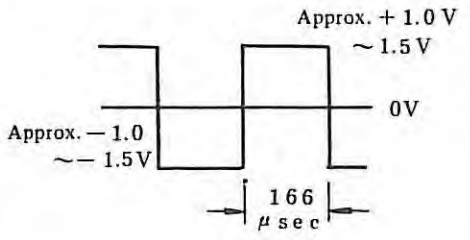
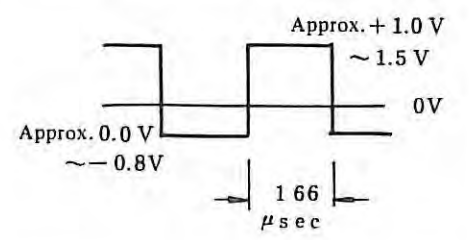
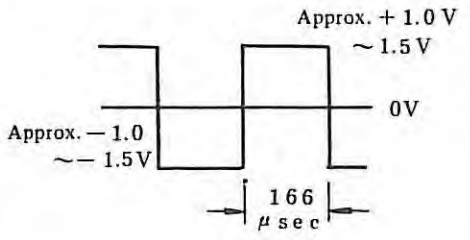
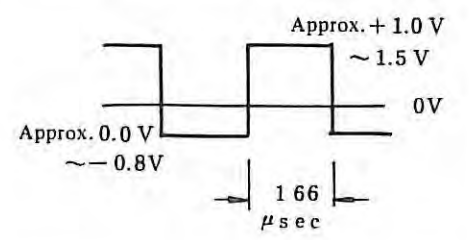
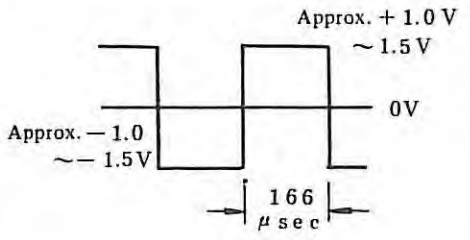
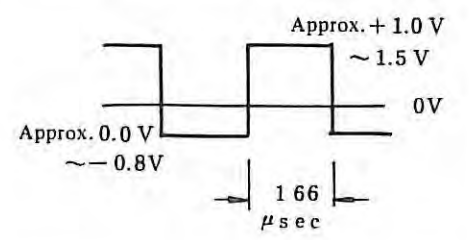
Steps	Contents						
5	<p>Check the transistor drive circuit on the PCB.</p> <p>① Turn on AC input power. Be sure not to specify rotation commands (SFR, SRV).</p> <p>② 12 points of voltage between the base and the emitter on transistors (U, V and W phases) using a tester. Take care of high voltage around the drive circuit.</p> <p>Judgement</p> <table border="1" data-bbox="326 506 1411 688"> <thead> <tr> <th></th> <th>Voltage between base and emitter (emitter standard)</th> </tr> </thead> <tbody> <tr> <td>Normal</td> <td>Approx. -0.8 to -1.3 V</td> </tr> <tr> <td>Abnormal</td> <td>Approx. 0.0 to -0.8 V</td> </tr> </tbody> </table> <p>The waveforms in normal/abnormal are shown below.</p> <p>Note) Take care of high voltage (approx. 300 VDC) around the drive circuit.</p> <p>Specify the forward/reverse rotation command with 0 rpm of speed command. Observe waveform between the base and the emitter of transistors (U, V and W phases) on the lower PCB using an oscilloscope.</p>		Voltage between base and emitter (emitter standard)	Normal	Approx. -0.8 to -1.3 V	Abnormal	Approx. 0.0 to -0.8 V
	Voltage between base and emitter (emitter standard)						
Normal	Approx. -0.8 to -1.3 V						
Abnormal	Approx. 0.0 to -0.8 V						
6	<table border="1" data-bbox="326 1024 1411 1396"> <thead> <tr> <th data-bbox="326 1024 870 1087">Normal</th> <th data-bbox="870 1024 1411 1087">Abnormal</th> </tr> </thead> <tbody> <tr> <td data-bbox="326 1087 870 1396">  <p>Approx. +1.0 V ~ 1.5 V</p> <p>0V</p> <p>Approx. -1.0 ~- 1.5V</p> <p>166 μ sec</p> </td> <td data-bbox="870 1087 1411 1396">  <p>Approx. +1.0 V ~ 1.5 V</p> <p>0V</p> <p>Approx. 0.0 V ~- 0.8V</p> <p>166 μ sec</p> </td> </tr> </tbody> </table> <p>If the PCB is defective repair it using following steps. Check whether fuses F4A - F4M of the drive circuit are blown using a tester. When a fuse is blown, replace it and check the PCB following steps ① and ② in 5.</p>	Normal	Abnormal	 <p>Approx. +1.0 V ~ 1.5 V</p> <p>0V</p> <p>Approx. -1.0 ~- 1.5V</p> <p>166 μ sec</p>	 <p>Approx. +1.0 V ~ 1.5 V</p> <p>0V</p> <p>Approx. 0.0 V ~- 0.8V</p> <p>166 μ sec</p>		
Normal	Abnormal						
 <p>Approx. +1.0 V ~ 1.5 V</p> <p>0V</p> <p>Approx. -1.0 ~- 1.5V</p> <p>166 μ sec</p>	 <p>Approx. +1.0 V ~ 1.5 V</p> <p>0V</p> <p>Approx. 0.0 V ~- 0.8V</p> <p>166 μ sec</p>						
7	Connect the motor power line to restart an operation.						

7. SPINDLE ORIENTATION CONTROL CIRCUIT

This chapter describes maintenance, installation, and adjustment when the electric orientation function is added to the spindle of CNC machine tool.

7.1 Configuration

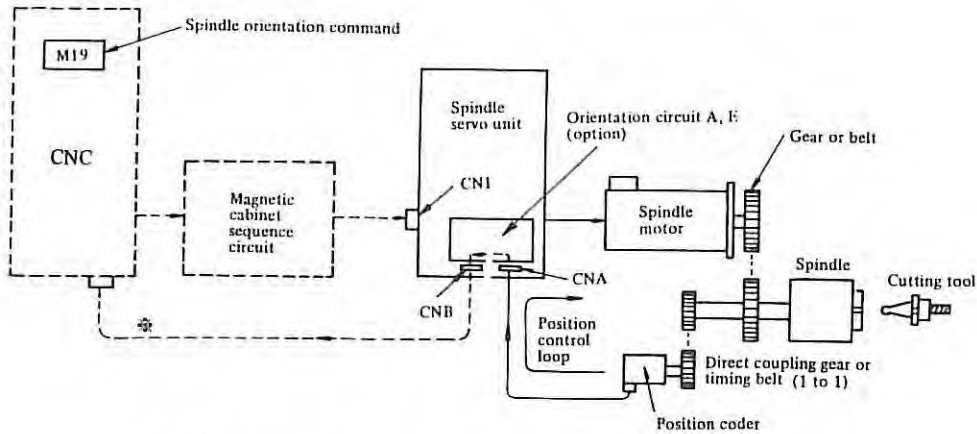

Fig. 7.1 (a) Configuration of spindle orientation using position coder
(Internal stop position setting type)

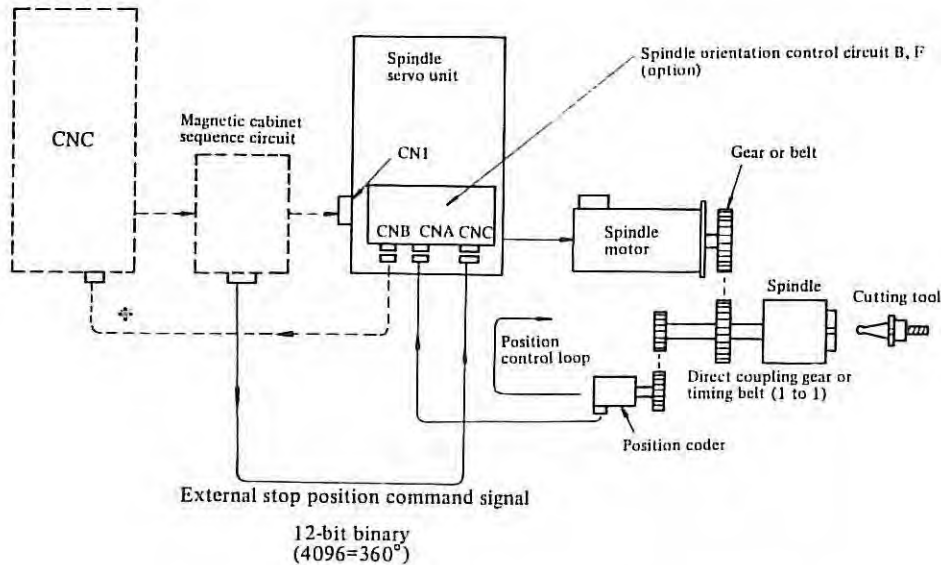

Fig. 7.1 (b) Configuration of spindle orientation using position coder
(External stop position command type)

- Note 1) If a position coder has been mounted on a lathe, etc., it can be used.
 Note 2) Asterisked cable route is employed when the position coder for the lathe or synchronous feed in machining center is combined.

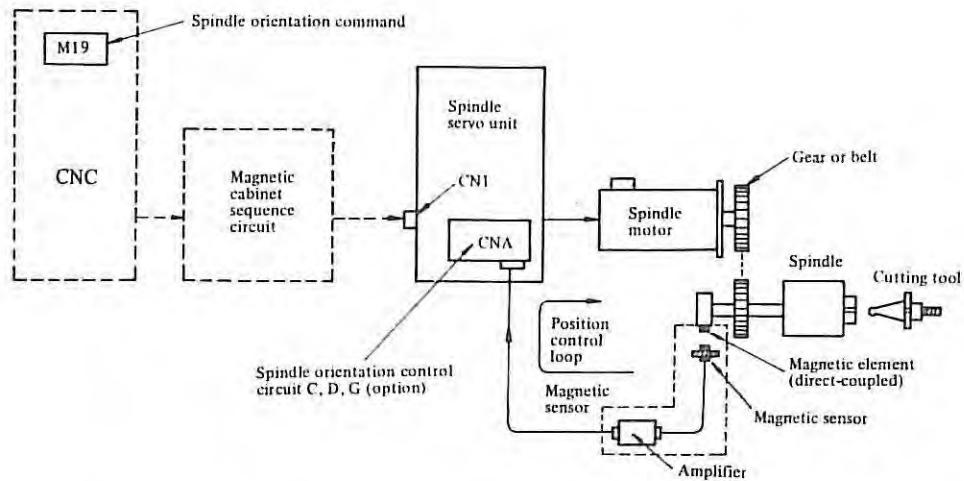

Fig. 7.1 (c) Configuration of spindle orientation using magnetic sensor

7.2 Adjusting Spindle Orientation Control Circuit of Position Coder System

7.2.1 Setting and adjusting spindle orientation control circuit in 2-step spindle speed change or less

Following functions are required:

Models 1S - 3S : Orientation AR11, BR11 (A06B-6059-J110, J111)

Models 6S - 22S: Orientation AS11, BS11 (A06B-6059-J130, J131)

Setting and adjustment of PCB (A20B-0008-0242, 0243, used for models 1S - 3S and 6S - 22S) are described below.

1) Display contents

The following display is done using LED.

LED No.	Symbol	Lighting color	Description
LED 1	ORIENTATION	Green	Lights when orientation command (ORCM1, 2 ON) is input.
LED 2	LOW	Green	Lights when clutch switching signal *CTH contact is closed. It means that clutch LOW is selected.
LED 3	IN-POSITION OUT	Green	Lights when orientation end signal ORAR1-2 is sent.
LED 4	IN-POSITION ADJUST	Green	Lights when spindle enters within 1 pulse width of orientation command position. Adjust OFFSET adjusting RV3/RV5 so that this LED4 lights at gear HIGH/LOW, and the stop positions at gear HIGH and LOW coincide with each other.

2) Setting

a) Setting power supply of position coder

If the power supply +5 V of position coder is supplied from the spindle amplifier, short the circuit between +5V - 5H and 0G - 0V. Open the circuit between +5V - 5H and 0G - 0V when +5 V is supplied from CNC machine tool.

b) Setting jumpers T6 - T14

Position coder	Jumpers T6 - T14
Balanced	A side: ON
Unbalanced	B side: ON

c) Setting jumpers SH01, SH02 and SH03
Make setting using the table below.

d) Setting position switches (SW1, 2, 3)

Setting switch	Pulse number per 1 division	Angle per 1 division
SW1	$4096/16 = 256$ pulses	Every 22.5°
SW2	$256/16 = 16$ pulses	Every 1.4°
SW3	$16/16 = 1$ pulse	Every 0.088°

SW1 to SW3 are digital switches with 16 scale.

The spindle motor can be stopped at any position in one rotation in the unit of $1/4096 \times 360^\circ = 0.088^\circ$ by setting these switches in the order of SW1, SW2, SW3.

3) Adjustments

No.	Item	Name of variable resistor	Standard adjustment (Division)	Measuring point	Description
1	Speed feedback voltage offset	RV1	5	TSA2 CH14 (TSA2)	Adjust RV1 until TSA2 voltage becomes 0 ± 1 mV.
2	Gear HIGH position gain	RV2	3 - 4	Spindle motion or CH14	Set the gain to the maximum within a range where the spindle does not overshoot.
3	Gear HIGH offset	RV3	About 5	LED4 (ADJUST)	Adjust RV3 until LED4 lights or flickers.
4	Gear LOW position gain	RV4	3 - 6	Spindle motion or CH14	Set the gain to the maximum within a range where the spindle does not overshoot.
5	Gear LOW offset	RV5	About 5	LED4 (ADJUST)	Adjust RV5 until LED4 lights or flickers.
6	Speed loop gain	RV6DC (DC motor)	0	CH14	Make sure that motor is not hunting. The rigidity increases during stop by turning these RV clockwise.
		RV6AC (AC motor)	7	CH14	

7.3 Adjusting Spindle Orientation Control Circuit of Magnetic Sensor Type

7.3.1 Mounting magnetizing element and magnetic sensor

Determine the mounting directions of the magnetizing element and magnetic sensor according to the following procedure. If they are not mounted correctly, the spindle may repeat normal rotation and reverse rotation without being stopped, the hunting occurs, or the spindle stops at the position where the magnetizing element end is opposite to the sensor head.

Mounting procedure of magnetizing element and magnetic sensor

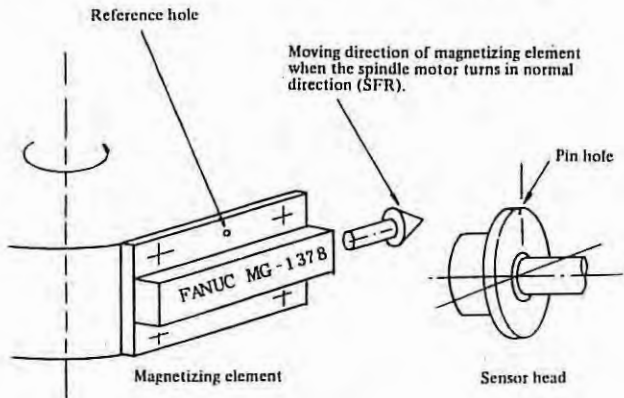
Item	Procedure
1	Mount the magnetizing element is such a way as the reference hole faces as shown in Fig. 7.3.1 when the spindle is turned by the spindle motor normal rotation command (SFR, VCMD: Positive).
2	Mount the magnetic sensor head so that the pin hole of the flange is opposite to the reference hole.
3	<p>Adjust the gap between the magnetizing element and the sensor head, so that the minimum gap value ΔL becomes $\Delta L = 1.5 \pm 0.5$ mm.</p>  <p style="text-align: center;">Fig. 7.3.1 (a) Mounting direction of magnetizing element (Reference drawing)</p>

7.3.2 Setting and adjusting spindle orientation control circuit in 2-step speed spindle for standard type

Following functions are required:

Models 1S - 3S : Orientation CR (A06B-6059-J120)

PCB (A16B-1300-0110)

Models 6S - 22S: Orientation CSII (A06B-6059-J140)

PCB (A20B-0008-0032)

Setting and adjustment of PCB are described below. See Fig. 7.3.2 (a), (b).

1) Setting jumpers SH01 - SH05

Table 7.3.2 (a) shows the setting and functions of jumpers. Select these jumpers by user.

Terminal SH01 is provided for adjustment and testing at site. Set this SH01 terminal after turning on the power supply, and disconnect it after adjustment without fail. Make sure that LED7 goes out.

Table 7.3.2 (a) Setting jumpers (SH)

			Jumpers (The double frame indicates standard setting)	
Setting (Note 1)			Function	Remarks
SH	1-2	2-3		
01		o	Sets the test mode. (Note 2)	Set for adjustment only.
02	o	x	Rotates the motor shaft clockwise when the orientation command is given before operating the spindle after turning on the power.	SH03 setting takes precedence of SH02. This is effective only when 1-2 pins of SH03 are shorted.
	x	o	Rotates the motor shaft counter-clockwise when the orientation command is given before operating the spindle after turning on the power.	
03	o	x	Orients in the direction of the spindle rotation just before the orientation command was given.	SH02 setting becomes effective.
	x	o	Always orients the spindle counter-clockwise.	
	x	x	Always orients the spindle clockwise.	
04	x	x	Sets the initial orientation speed of the spindle: Approx. 60 x (spindle position loop gain, sec ⁻¹) rpm	Since the position loop gain of spindle is 5 sec ⁻¹ in general, the initial speed is about 300 rpm without limitation.
	o	x	Limits the initial orientation speed to 1/3.	
	x	o	Limits the initial orientation speed to 2/3.	
05	o	x	For DC spindle servo unit.	
	x	o	For AC spindle servo unit.	

Note 1) o indicates short, while x indicates open.

Note 2) Use of the TEST MODE

- (1) Turn on the spindle orientation command.
- (2) Spindle orientation end signals (ORAR1, 2) are not sent.
- (3) The spindle turns at the initial orientation speed, while the SW1 (INITIALIZING BUTTON) is being pressed and the spindle stops at the specific position when SW1 is released.)
- (4) Red LED7 lights in this mode.

2) LED

Seven indicator lamps LED1 - 7 are mounted on spindle orientation control circuits CR, GR, CSII and GSII. The following table shows their display contents.

Neither LED1 nor LED2 is mounted on PCB of 01A version.

LED display contents			
LED	Display contents	Lighting color	Description
1	ORIENTATION (In orientation)	Green	Lights when spindle orientation command is given (ORCM1 and 2 are shorted).
2	LOW (LOW clutch (gear))	Green	Lights when LOW clutch (gear) signal is turned on (*CTH1 and 2 are shorted).
3	MS PEAK LEVEL (Magnetic flux detection signal peak value adjusting indicator)	Green	This adjusting indicator lights when the peak value of the magnetic flux detection signal (MS) exceeds +10 V.
4	SLOWDOWN PERIOD (Low-speed rotation period adjusting indicator)	Green	Lights when the spindle approaches the stop position and enters the low speed rotation area during spindle orientation motion.
5	IN POSITION FINE (In-position adjusting indicator)	Green	Lights when the magnetic flux signal (output) value is within the setting range of 0.1° as a converted spindle angle. This LED5 may also light when the sensor is not positioned on the magnetizing element.
6	IN-POSITION (In-position)	Green	Lights when the spindle is within +1° of the aimed adjusting position after completion of spindle orientation. The spindle orientation end signal (ORAR1 and 2 are shorted) is sent when this LED is lighting in a mode other than TEST mode.
7	TEST MODE (In test mode)	Red	Lights when setting terminal SH01 pins are shorted. The orientation end signal is not sent in this mode even if the orientation motion is executed.

3) Setting variable resistors

Adjust the variable resistor as shown in the following table before starting adjustments.

Asterisked items are readjusted during adjustment procedure described later. Set these items also as the preliminary setting.

Adjusting variable resistor

Orientation	Variable resistor												
	RV1 *	RV2 *	RV3	RV4	RV5	RV6 *	RV7 *	RV8	RV9 *	RV10 *	RV11 *	RV12 DC	RV12 AC
ARII, BRII, ASII, BSII, CSII, GSII	5.0	6.0	See (a)	See (a)	See (b)	2.0	5.0	See (c)	2.0	5.0	5.0	0	7.0
CR		5.0											
GR		6.0											

a) RV3, RV4

Follow the distance H between the rotational center of magnetic element and center of sensor head surface.

H (mm)	60 to 65	To 70	To 75	To 80	To 85	To 90	To 95	To 100	To 105	To 110
Division	7.0	6.0	5.0	4.0	3.0	2.5	2.0	1.5	1.0	0.5

b) RV5

Follow the number of HIGH spindle rotation (Nhm) at rated speed.

Nhm (rpm)	2000 to 2200	To 2500	To 2700	To 3100	To 3500	To 4000	To 4500	To 5000	To 5500	To 6000
Division	7.5	6.5	5.5	4.5	3.5	2.5	2.0	1.5	1.0	0.5

c) RV8

Follow the gear ratio Rh/l of HIGH/LOW spindle.

Rh/l	To 2.0	To 2.2	To 2.5	To 2.8	To 3.2	To 3.7	To 4.4	To 5.3	To 6.0	To 7.0
Division	2.0	3.0	4.0	5.0	6.0	7.0	8.0	9.0	9.5	10.0

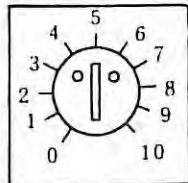

Division of variable resistor

4) Adjusting variable resistors

Adjust RV1 - 12, 12DC, and 12AC according to the following table. Adjust the offset and gain of spindle control circuit PCB before adjusting the orientation circuit. When RV12 and RV13 of the spindle control circuit PCB are changed, the stop position may be deviated.

Table 7.3.2 (b) Adjusting variable resistors

Set the test mode for the following adjustments by shorting SH01 pins.

Item	Name of variable resistor	Item to be adjusted	Conditions	Adjusting method (specification)
1	RV1	TS OFFSET Tachogenerator offset. (Compensation for the difference of the slow down time in normal and reverse rotating direction)	Compare the slow down time during the orientation in normal and reverse directions after completion of this adjustments.	The standard setting value is 5 divisions. Adjust RV1 until the difference of the slow down time between normal and reverse rotation becomes shorter than 0.1 sec.
2	RV2	MS PEAK LEVEL MS signal amplitude value.	Keep pressing SW1 (initializing button).	Set VR2 to the position where LED3 (MS PEAK LEVEL) starts flickering.
3	RV3	SLOWDOWN REFERENCE Slowdown speed reference.		See 7.3.2 (3)-(a).
4	RV4	AMS PEAK LEVEL AMS signal amplitude value.		See 7.3.2 (3)-(a).
5	RV5	SLOWDOWN TIME IN HIGH MODE Slowdown time in clutch (gear) high mode.	Set the clutch (gear) HIGH mode. Stop the spindle at the fixed position by depressing SW1 once. *CTH signal is OFF (option).	LED4 (SLOWDOWN PERIOD) should clearly light at a moment just before the spindle stops.
6	RV6	GAIN (H) Position loop gain.	Same as specified above.	Turn RV6 clockwise to such an extent as does not cause any overshoot when the spindle stops.
7	RV7	IN-POSITION (H) Spindle stop position (H).	Same as specified above.	LED5 (IN-POS FINE) should light during lighting of LED6 (IN-POSITION).

Item	Name of variable resistor	Item to be adjusted	Conditions	Adjusting method (specification)
8	RV8	SLOWDOWN TIME IN LOW MODE Slowdown time in clutch (gear) low mode.	Set the clutch (gear) LOW mode. Stop the spindle at the fixed position by depressing SW1 once. *CTH signal is turned on (closed).	LED (SLOWDOWN PERIOD) should clearly light at a moment just before the spindle stops. (See item 5 in this table.)
9	RV9	GAIN (L) Position loop gain.	Same as specified above.	Turn RV9 clockwise to such an extent as does not cause any overshoot when the spindle stops.
10	RV10	IN-POSITION (L) Spindle stop position (L).	Same as specified above.	LED5 (IN-POS FINE) should light during lighting of LED6 (IN-POSITION).
11	RV11	POSITION SHIFT Spindle stop position shift.		The spindle stop position can be finely adjusted within a range $\pm 1^\circ$ the spindle angle.
12	RV12 DC	HIGH GAIN DC High gain.	Adjust RV12 when DC spindle servo unit is used.	Standard adjusting value: 0 divisions.
13	RV12 AC	HIGH GAIN AC High gain.	Adjust RV12 when AC spindle servo unit is used.	Standard adjusting value: 7 divisions.

After adjustments, cancel the test mode, and make sure that the LED7 (red) goes out.

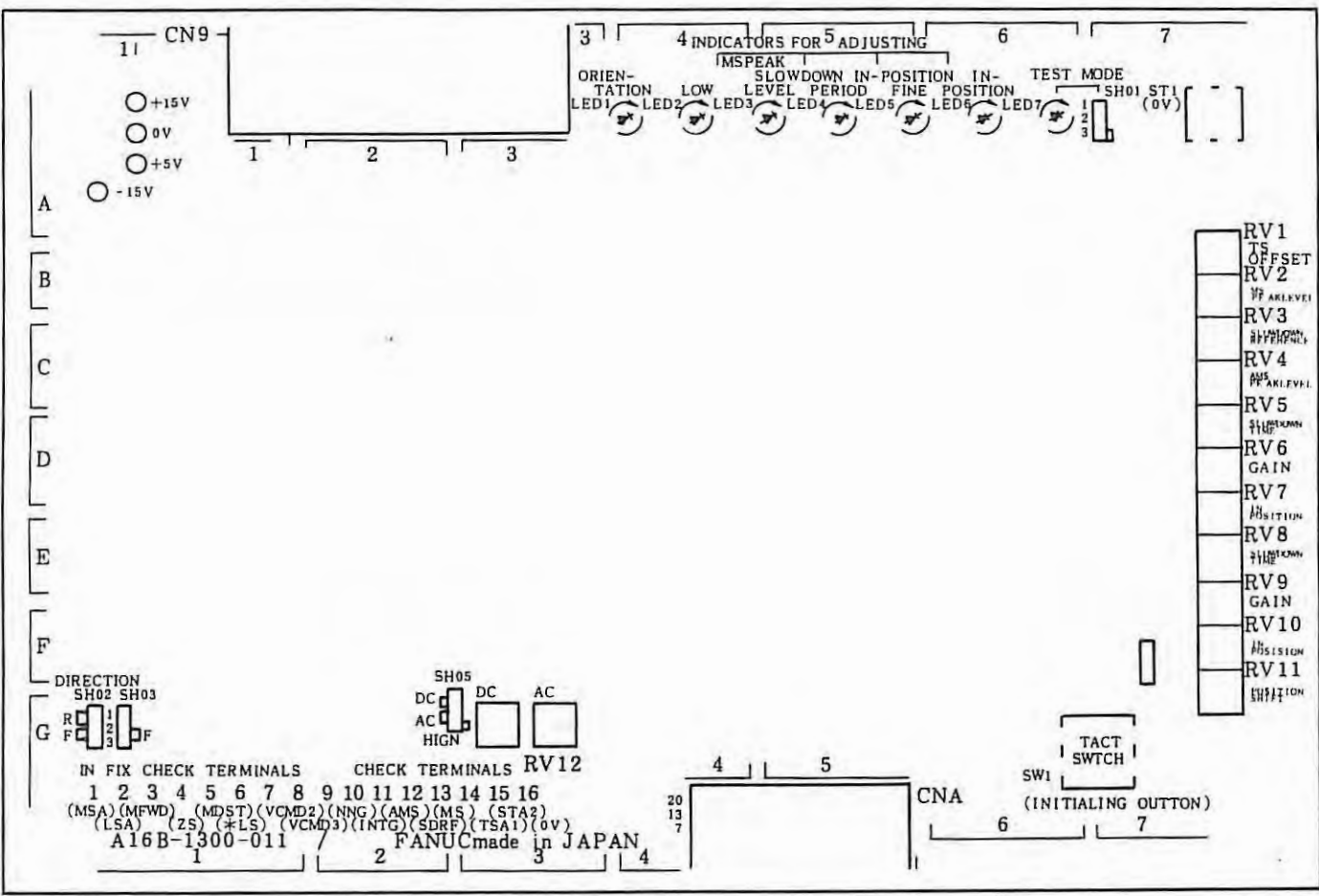
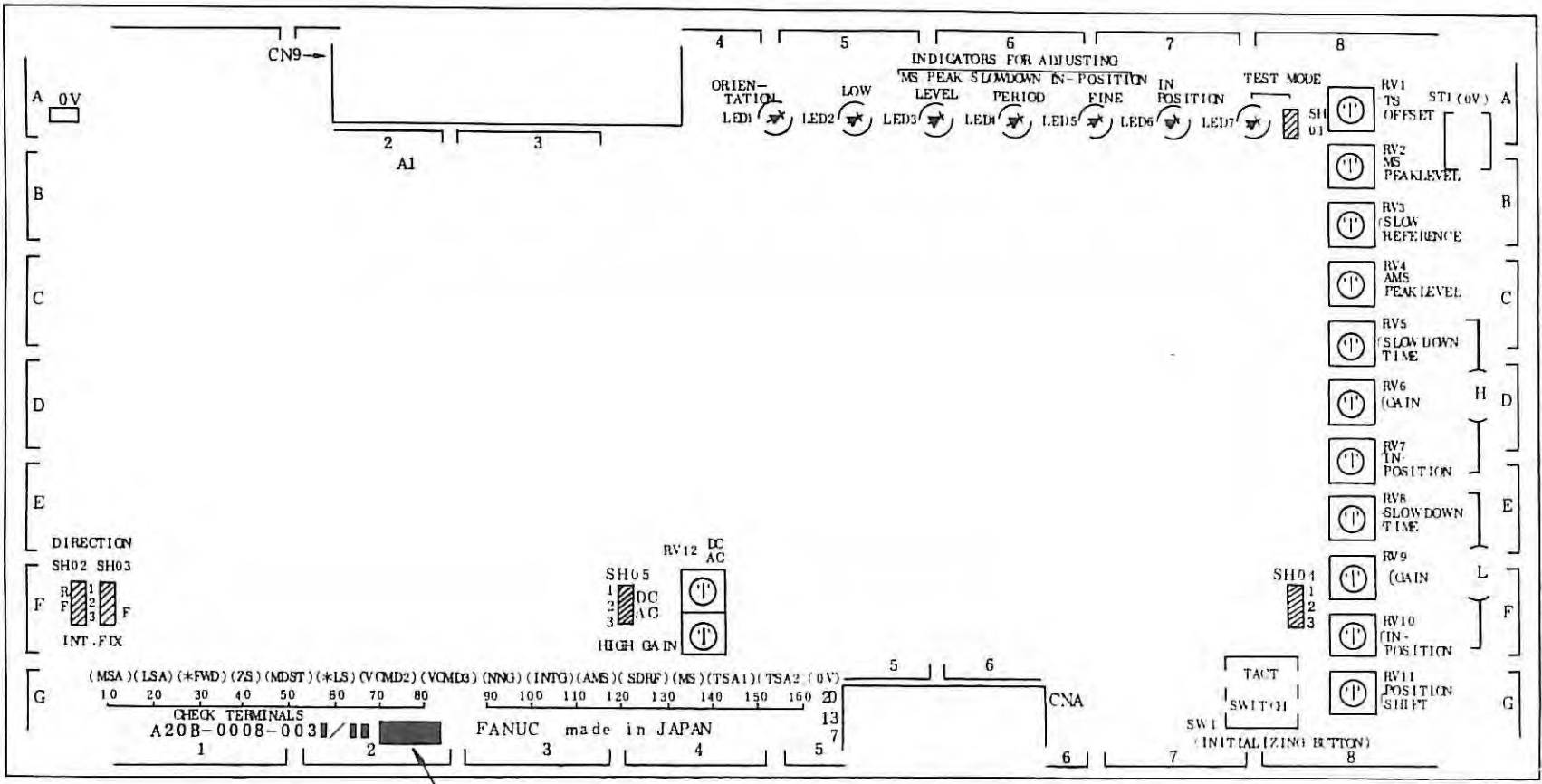

Fig. 7.3.2 (a) Location of test pins, variable resistors, jumpers and LEDs
 (PCB: A16B-1300-0110, 0111) (models 1S - 3S with magnetic sensor)

Fig. 7.3.2 (b) Location of test pins, variable resistor, jumpers and LEDs
 (PCB: A20B-0008-0032, 0033) (models 6S - 22S with magnetic sensor)



Total version No.

7.3.3 Setting and adjusting spindle orientation control circuit in 2-step speed spindle for high speed type

Following functions are required:

Models 1S - 3S : Orientation GR (A06B-6059-J121)
PCB (A16B-1300-0111)

Models 6S - 22S: Orientation GSII (A06B-6059-J141)
PCB (A20B-0008-0033)

Setting and adjustment of PCB are described below. See Fig. 7.3.2 (a), (b).

1) Setting jumpers SH01-SH05

Table 7.3.3 (a) shows the setting and functions of jumpers. Select these jumpers by the MTB.

The jumper SH01 is provided for adjustment and test. Set this SH01 after turning on the power, and always open it after adjustment.

Make sure that LED7 goes out.

Table 7.3.3 (a) Setting jumpers (SH)

			Jumpers (The double frame indicates standard setting)			
Setting (Note 1)			Function	Remarks		
SH	1-2	2-3				
01		o	Sets the test mode. (Note 2)	Set for adjustment only.		
02	o	x	Rotates the motor shaft clockwise when the orientation command is given before operating the spindle after turning on the power.	SH03 setting takes precedence of SH02. This is effective only when 1-2 pins of SH03 are shorted.		
	<table border="1" style="display: inline-table; vertical-align: middle;"><tr><td>x</td><td>o</td></tr></table>	x	o			Rotates the motor shaft clockwise when the orientation command is given before operating the spindle after turning on the power.
x	o					
03	<table border="1" style="display: inline-table; vertical-align: middle;"><tr><td>o</td><td>x</td></tr></table>	o	x		Orients in the direction of the spindle rotation just before the orientation command was given.	SH02 setting becomes effective.
	o	x				
	x	o	Always orients the spindle counter-clockwise.			
x	x	Always orients the spindle clockwise.				

Setting (Note 1)			Function	Remarks
SH	1-2	2-3		
04	x	x	Sets the initial orientation speed of the spindle: Approx. 60 x (spindle position loop gain, sec ⁻¹) rpm	Since the position loop gain of spindle is 5 sec ⁻¹ in general, the initial speed is about 300 rpm without limitation.
	<input type="checkbox"/>	<input checked="" type="checkbox"/>	Limits the initial orientation speed to 1/3.	
	<input checked="" type="checkbox"/>	<input type="checkbox"/>	Limits the initial orientation speed to 2/3.	
05	<input type="checkbox"/>	<input checked="" type="checkbox"/>	For DC spindle servo unit.	
	<input checked="" type="checkbox"/>	<input type="checkbox"/>	For AC spindle servo unit.	

Note 1) o indicates short, while x indicates open.

Note 2) Use of the TEST MODE.

- (1) Turn on the spindle orientation command.
- (2) Spindle orientation end signals (ORAR1, 2) are not sent.
- (3) The spindle turns at the initial orientation speed, while the SW1 (INITIALIZING BUTTON) is being pressed and the spindle stops at the specific position when SW1 is released.)
- (4) Red LED7 lights in this mode.

2) LED

Seven indicator lamps LED1 - 7 are mounted on spindle orientation control circuits GR and GSII. The following table shows their display contents.

LED display contents			
LED	Display contents	Lighting color	Description
1	ORIENTATION (In orientation)	Green	Lights when spindle orientation command is given (ORCM1 and 2 are shorted).
2	LOW (LOW clutch (gear))	Green	Lights when LOW clutch (gear) signal is turned on (*CTH1 and 2 are shorted).
3	MS PEAK LEVEL (Magnetic flux detection signal peak value adjusting indicator)	Green	This adjusting indicator lights when the peak value of the magnetic flux detection signal (MS) exceeds <u>+10 V.</u>

LED display contents			
LED	Display contents	Lighting color	Description
4	SLOWDOWN PERIOD (Low-speed rotation period adjusting indicator)	Green	Lights when the spindle approaches the stop position and enters the low speed rotation area during spindle orientation motion.
5	IN POSITION FINE (In-position adjusting indicator)	Green	Lights when the magnetic flux signal (output) value is within the setting range of 0.1° as a converted spindle angle. This LED5 may also light when the sensor is not positioned on the magnetizing element.
6	IN-POSITION (In-position)	Green	Lights when the spindle is within $\pm 1^\circ$ of the aimed adjusting position after completion of spindle orientation. The spindle orientation end signal (ORAR1 and 2 are shorted) is sent when this LED is lighting in a mode other than TEST mode.
7	TEST MODE (Test mode)	Red	Lights when SH01 pins are shorted. The orientation end signal is not sent in this mode even if the orientation motion is executed.

3) Variable resistors

Adjust the variable resistor as shown in the following table before starting adjustments.

Asterisked items are readjusted during adjustment procedure described later. Set these items also as the preliminary setting.

Setting and preparation of variable resistors

	RV1 *	RV2 *	RV3	RV4	RV5 *	RV6 *	RV7 *	RV8	RV9 *	RV10 *	RV11 *	RV12 DC	RV12 AC
Variable resistor scale position	5.0	5.0	See (a)	See (a)	See (b)	2.0	5.0	See (c)	5.0	5.0	5.0	0	8.0

a) RV3, RV4

Follow the distance H between the rotational center of magnetic element and the center of sensor head surface.

H (mm)	40 to 45	To 50	To 55	To 60	To 65	To 70	To 80	To 90	To 100	To 110
Division	9.5	7.0	5.0	4.0	3.0	2.5	2.0	1.5	1.0	1.0

b) RV5

Follow the number of HIGH spindle rotation at rated speed.

Nhm (rpm)	6000 to 6500	To 7000	To 7500	To 8000	To 8500	To 9000	To 9500	To 10000	To 11000	To 12000
Division	6.0	5.0	4.5	4.0	3.5	3.0	2.5	2.5	2.0	1.0

c) RV8

Follow the gear ratio Rh/l of HIG/LOW spindle.

Rh/l	To 2.2	To 2.5	To 2.8	To 3.2	To 3.7	To 4.5	To 5.0	To 6.0	To 7.0
Division	2.0	3.0	4.0	5.0	6.0	7.0	8.0	8.0	9.0

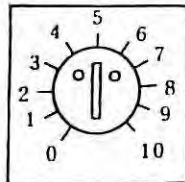

Division of variable resistor

4) Variable resistor

Adjust variable resistors RV1 - 12, 12DC, and 12AC following the table listed below. For adjusting the orientation circuit, first adjust the offset and gain of the spindle control circuit PCB to adjust the variable resistors. Note that the position may deviate when RV12 and 13 on the spindle control circuit PCB are changed.

Table 7.3.3 (b) Adjusting variable resistors

Set the test mode for the following adjustments by shorting SH01 pins.

No.	Name	Item	Conditions	Procedure
1	RV1	TS OFFSET Tachogenerator offset. (Compensation for the difference of the slow down time in forward and reverse rotational directions)	Compare the slow down time during the orientation in forward and reverse directions after completion of this adjustments.	The standard setting value is 5 divisions. Adjust RV1 until the difference of the slow down time between forward and reverse rotations becomes shorter than 0.1 sec.
2	RV2	MS PEAK LEVEL MS signal amplitude value.	Keep pressing SW1 (initializing button).	Set VR2 to the position where LED3 (MS PEAK LEVEL) starts flickering.
3	RV3	SLOWDOWN REFERENCE Slowdown speed reference.		See 7.3.3 (3)-(a).

No.	Name	Item	Conditions	Procedure
4	RV4	AMS PEAK LEVEL AMS signal amplitude value.		See 7.3.3 (3)-(a).
5	RV5	SLOWDOWN TIME IN HIGH MODE Slowdown time in clutch (gear) high mode.	Set the clutch (gear) HIGH mode. Stop the spindle at the fixed position by pressing SW1 once. *CTH signal is OFF (option).	LED4 (SLOWDOWN PERIOD) should clearly light at a moment just before the spindle stops.
6	RV6	GAIN (H) Position loop gain.	Same as specified above.	Turn RV6 clockwise up to the level not to make an overshoot when the spindle stops.
7	RV7	IN-POSITION (H) Spindle stop position (H).	Same as specified above.	LED5 (IN-POS FINE) should light during lighting of LED6 (IN-POSITION).
8	RV8	SLOWDOWN TIME IN LOW MODE Slowdown time in low clutch (gear) mode.	Set the clutch (gear) LOW mode. Stop the spindle at the specific position by pressing SW1. *CTH signal is turned on.	LED (SLOWDOWN PERIOD) should clearly light at a moment just before the spindle stops.
9	RV9	GAIN (L) Position loop gain.	Same as specified above.	Turn RV9 clockwise up to the level not to make an overshoot when the spindle stops.
10	RV10	IN-POSITION (L) Spindle stop position (L).	Same as specified above.	LED5 (IN-POS FINE) should light during lighting of LED6 (IN-POSITION).
11	RV11	POSITION SHIFT Spindle stop position shift.		The spindle stop position can be finely adjusted within a range $\pm 1^\circ$ of the spindle angle.
12	RV12 DC	HIGH GAIN DC High gain.	For DC spindle servo unit.	Standard adjusting value: 0 divisions.
13	RV12 AC	HIGH GAIN AC High gain.	For AC spindle servo unit.	Standard adjusting value: 8 divisions.

After adjustments, cancel the test mode, and make sure that the LED7 (red) goes out.

7.3.4 Checking method of spindle position loop gain

The spindle position loop gain can be checked according to the following procedure. Check it after adjusting the spindle orientation control circuit.

Checking procedure of spindle position loop gain

1	Set the mode to TEST mode (LED7 ON) after shorting SH01 pins.
2	Release 1-2 and 2-3 pins of SH04 to release the limit of orientation speed.
3	Measure spindle rotation (Ns(H), Ns(L), rpm) when SW1 (initializing button) is pressed (on) and the spindle clutch (gear) is set to HIGH (*CTH1, 2: Open) and LOW (*CTH1, 2: Close), respectively.
4	<p>The spindle position loop gain can be obtained by the following formula.</p> $K_p (H \text{ or } L) \cong N_s (H \text{ or } L) / 55 (\text{sec}^{-1})$ <p>where Kp (H): Position loop gain when the spindle is set to HIGH gear (clutch). Kp (L): Position loop gain when the spindle is set to LOW gear (clutch).</p>

APPENDIX

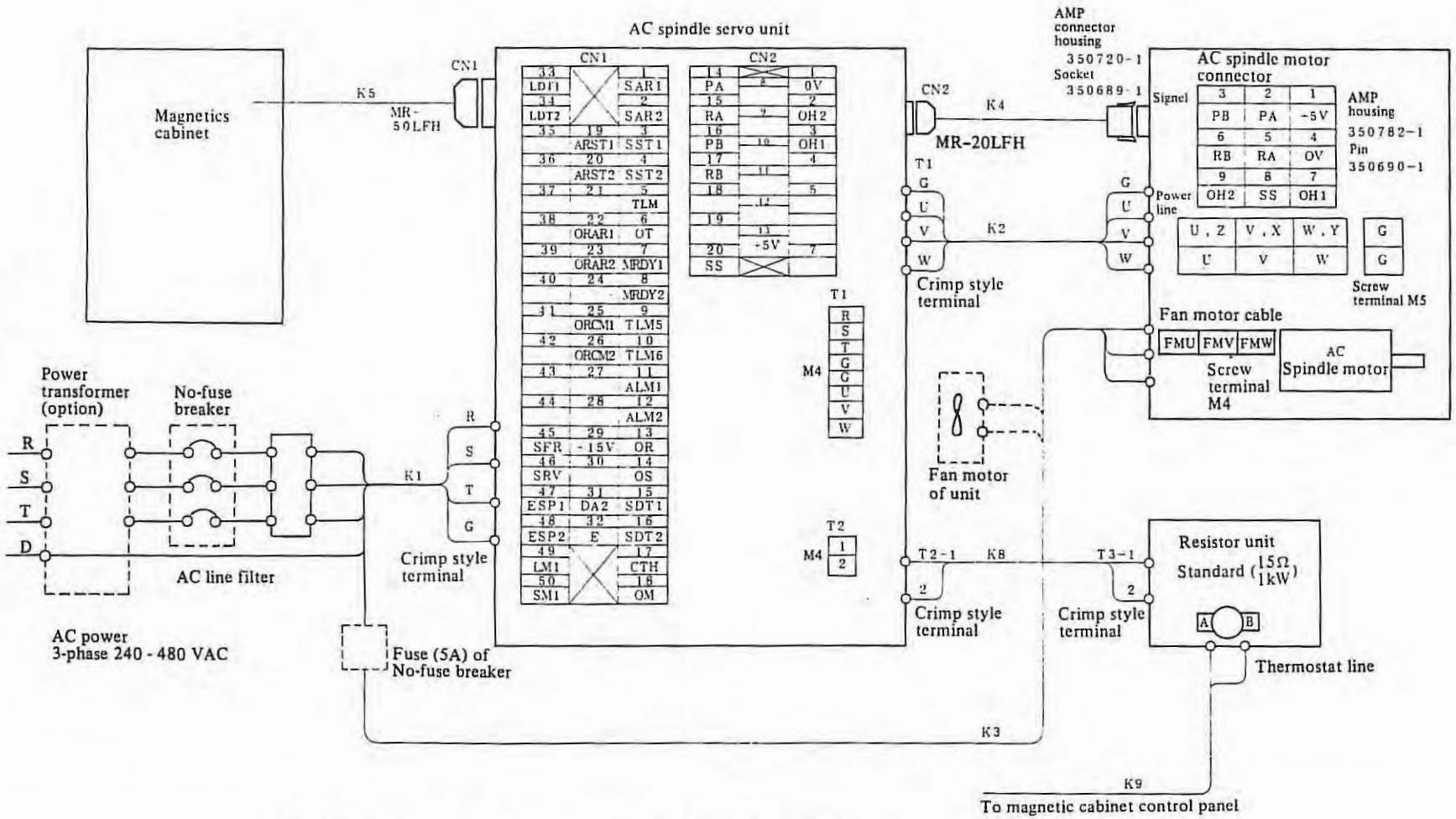
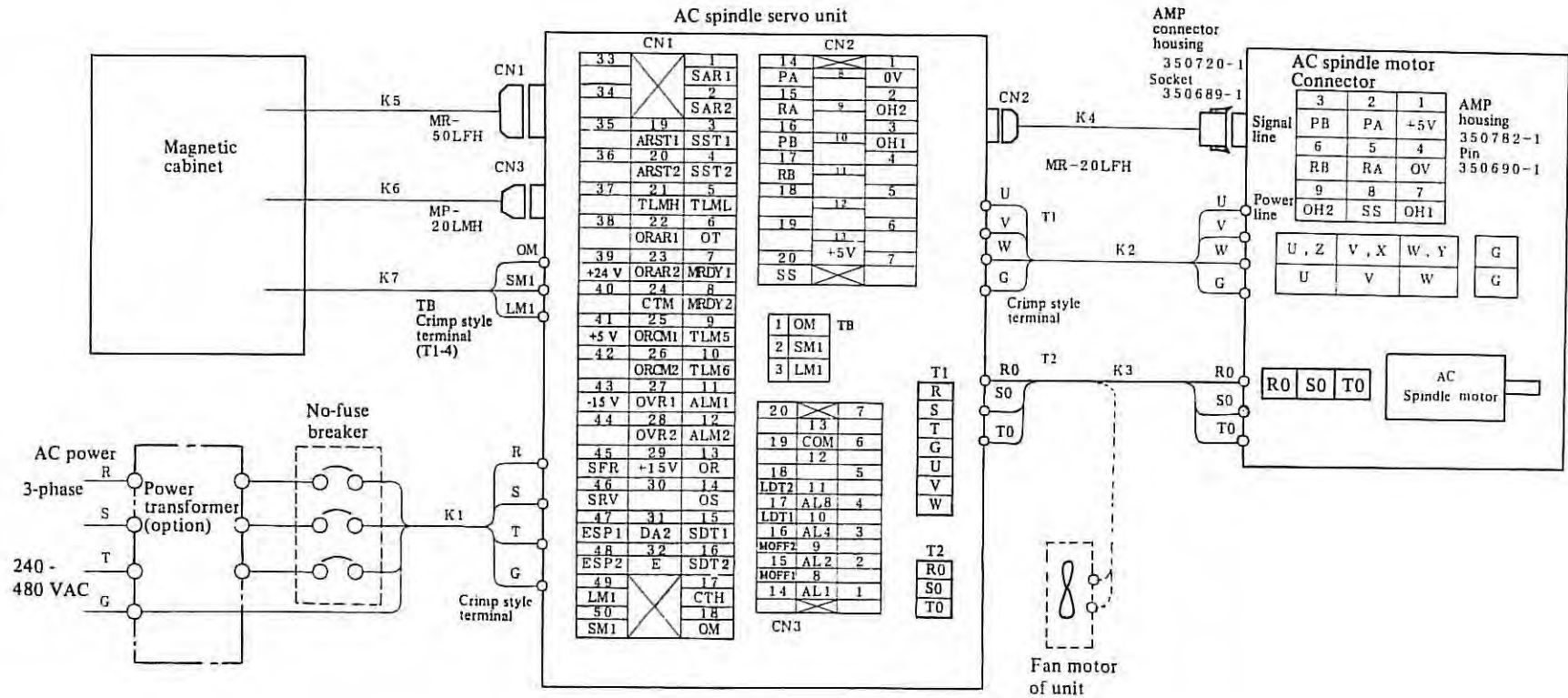

Fig. 1 (a) Connection diagram (models 1S - 3S)

Note) The fan motor of unit and no-fuse breaker are prepared by the MTB.

Fig. 1 (b) Connection diagram (models 6S - 22S)



Note) Fan motor and no-fuse breaker are provided by the MTB.

Fig. 1 (c) Spindle orientation connection diagram (models 1S - 3S with position coder)

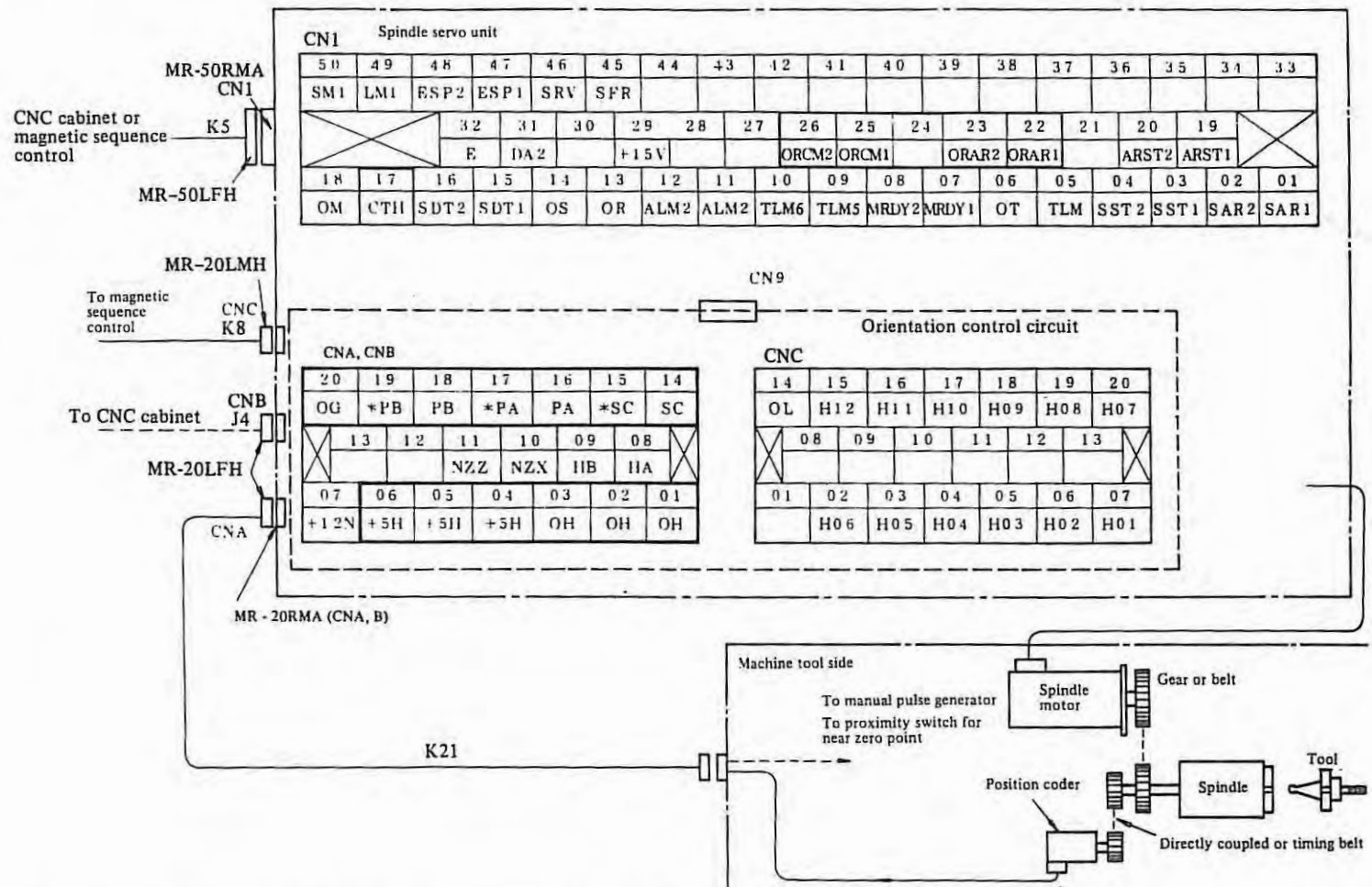

Note 1) Signal cable K22 applies to spindle orientation BR11.

Fig. 1 (d) Spindle orientation connection diagram (models 6S - 22S with position coder)

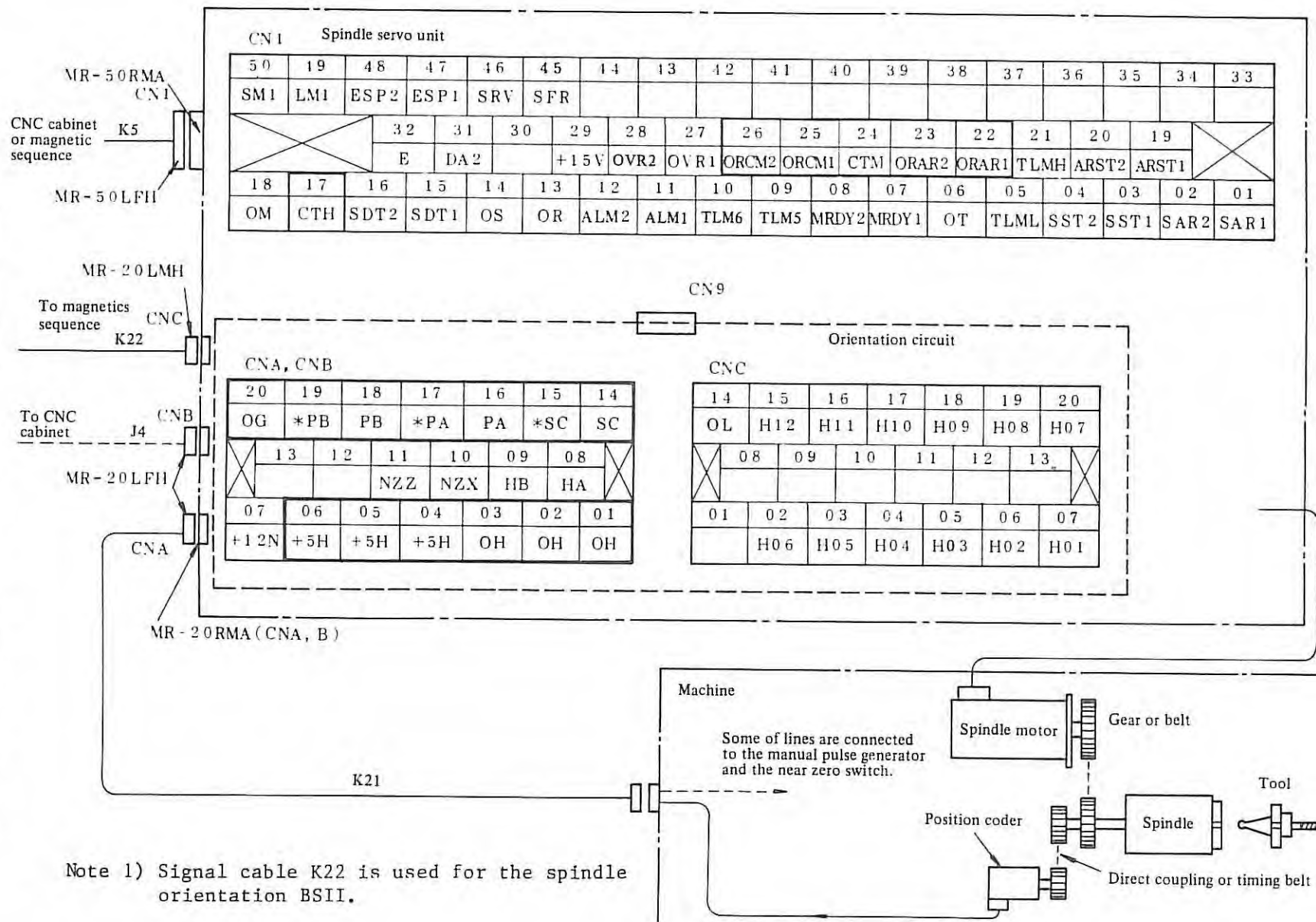

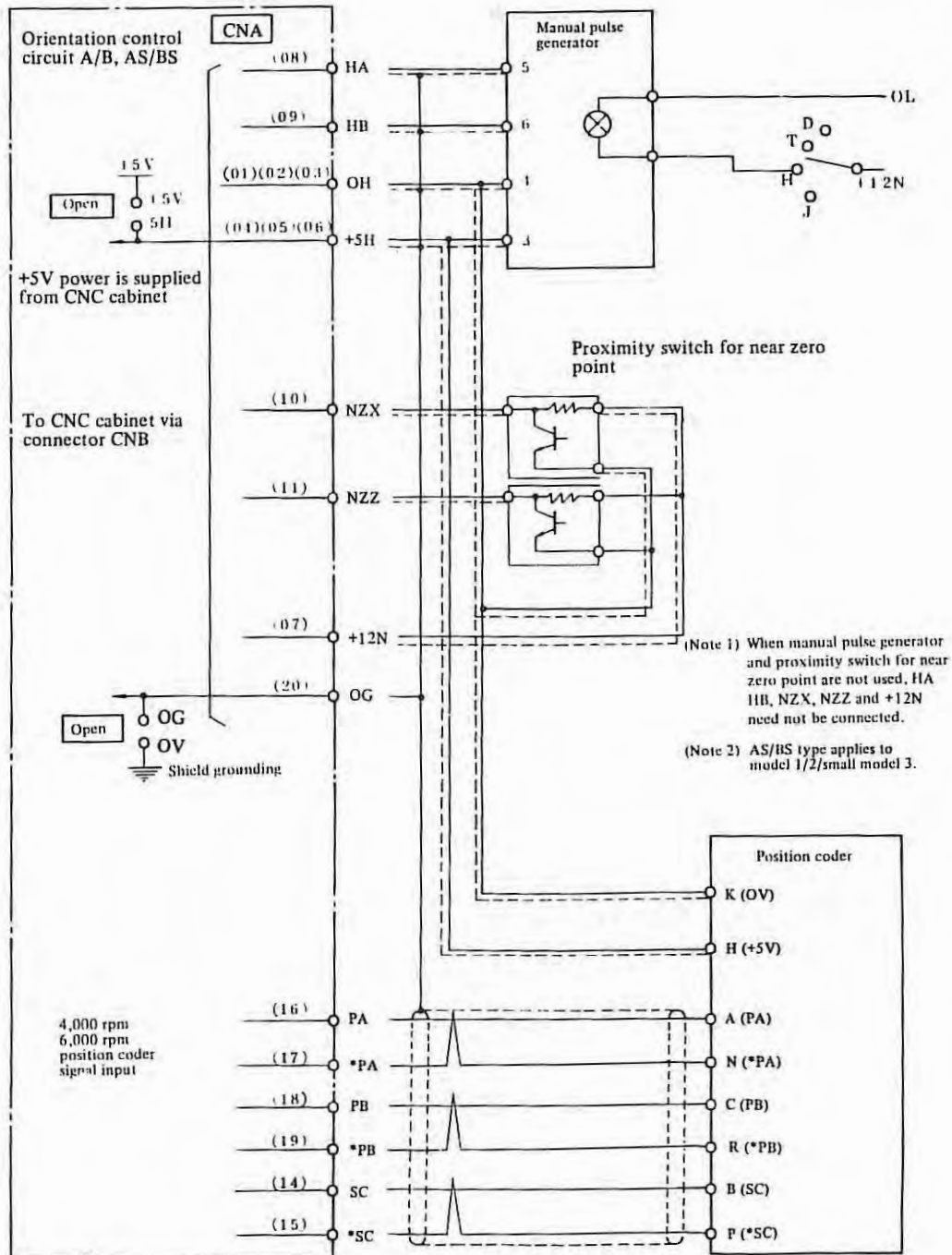
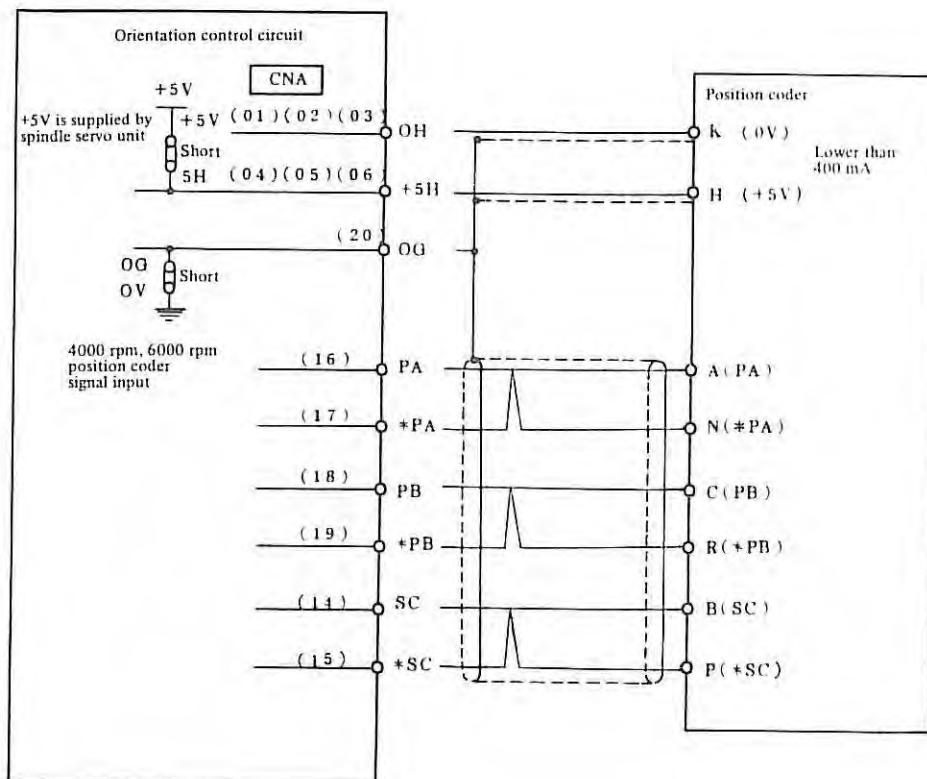

Fig. 1 (e) Spindle orientation connection diagram using position coder
(For lathe and synchronous feed of machining center)



Note) The cable length should be shorter than 20 m between the servo unit and the position coder.

Fig. 1 (f) Spindle orientation connection diagram using position coder
(Only spindle orientation for machining center is used)

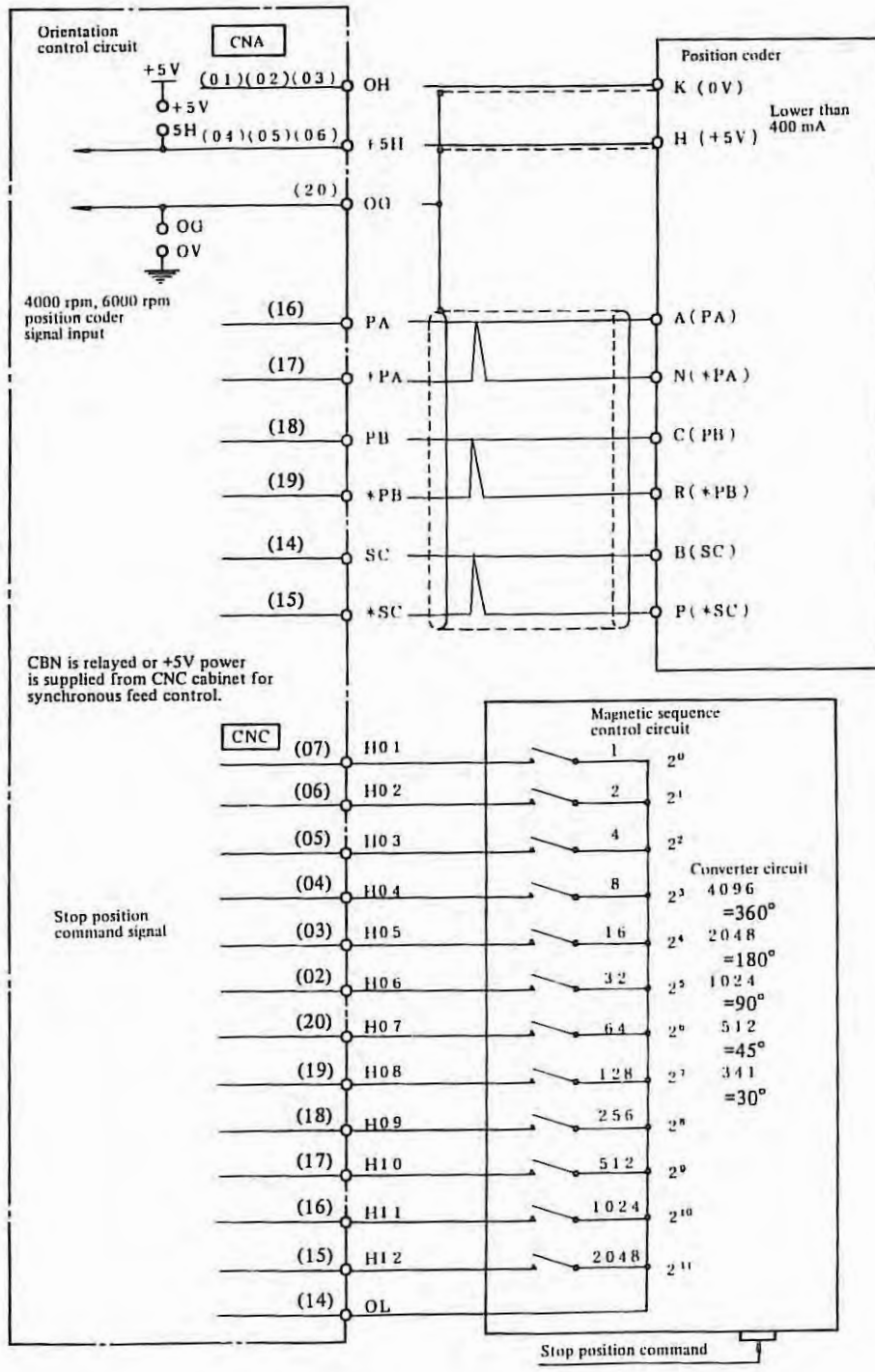

Fig. 1 (g) Spindle orientation connection diagram using position coder (External command of stop position)

Fig. 1 (h) Spindle orientation connection diagram using built-in sensor

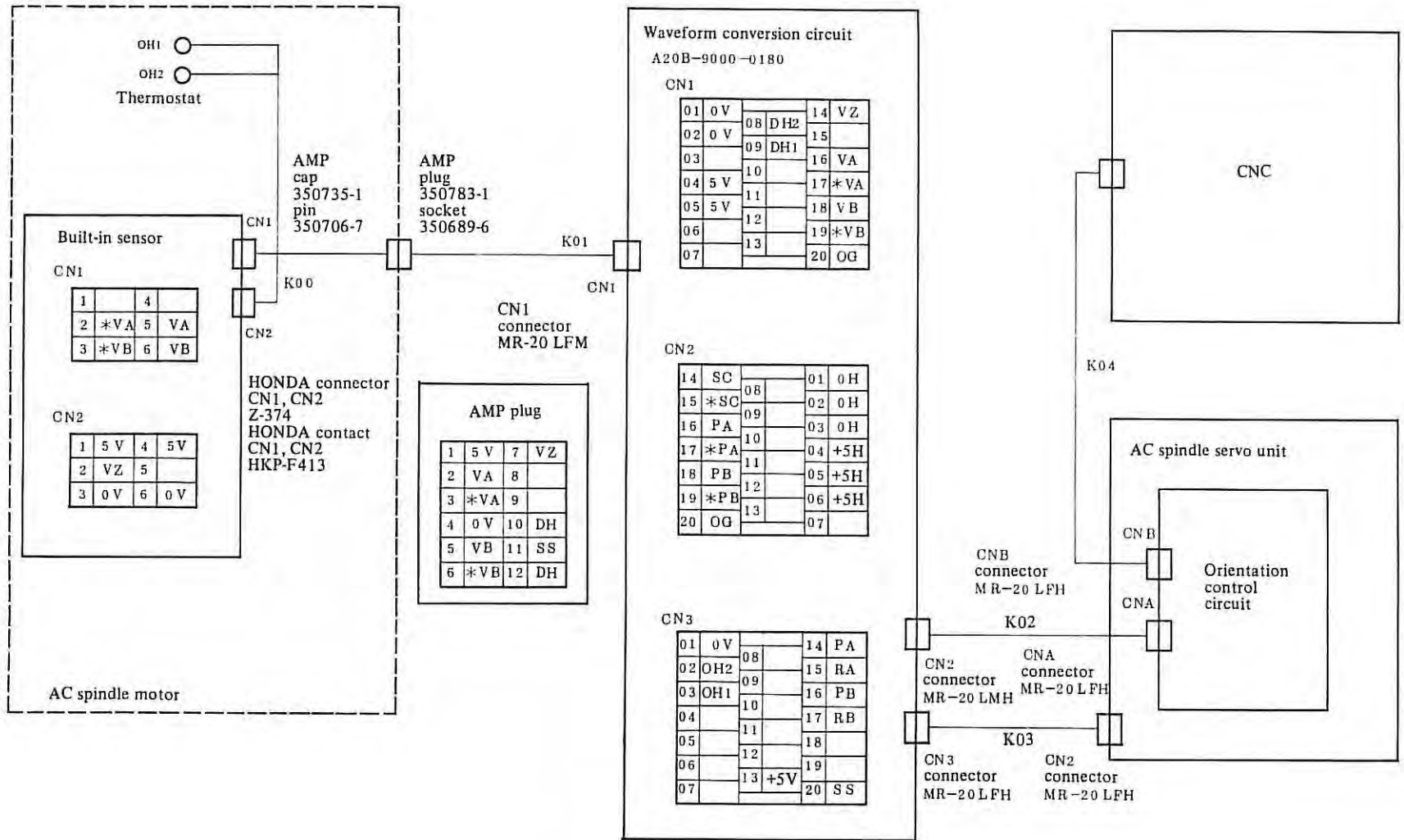

Fig. 1 (i) Spindle orientation connection diagram (models 1S - 3S with magnetic sensor)

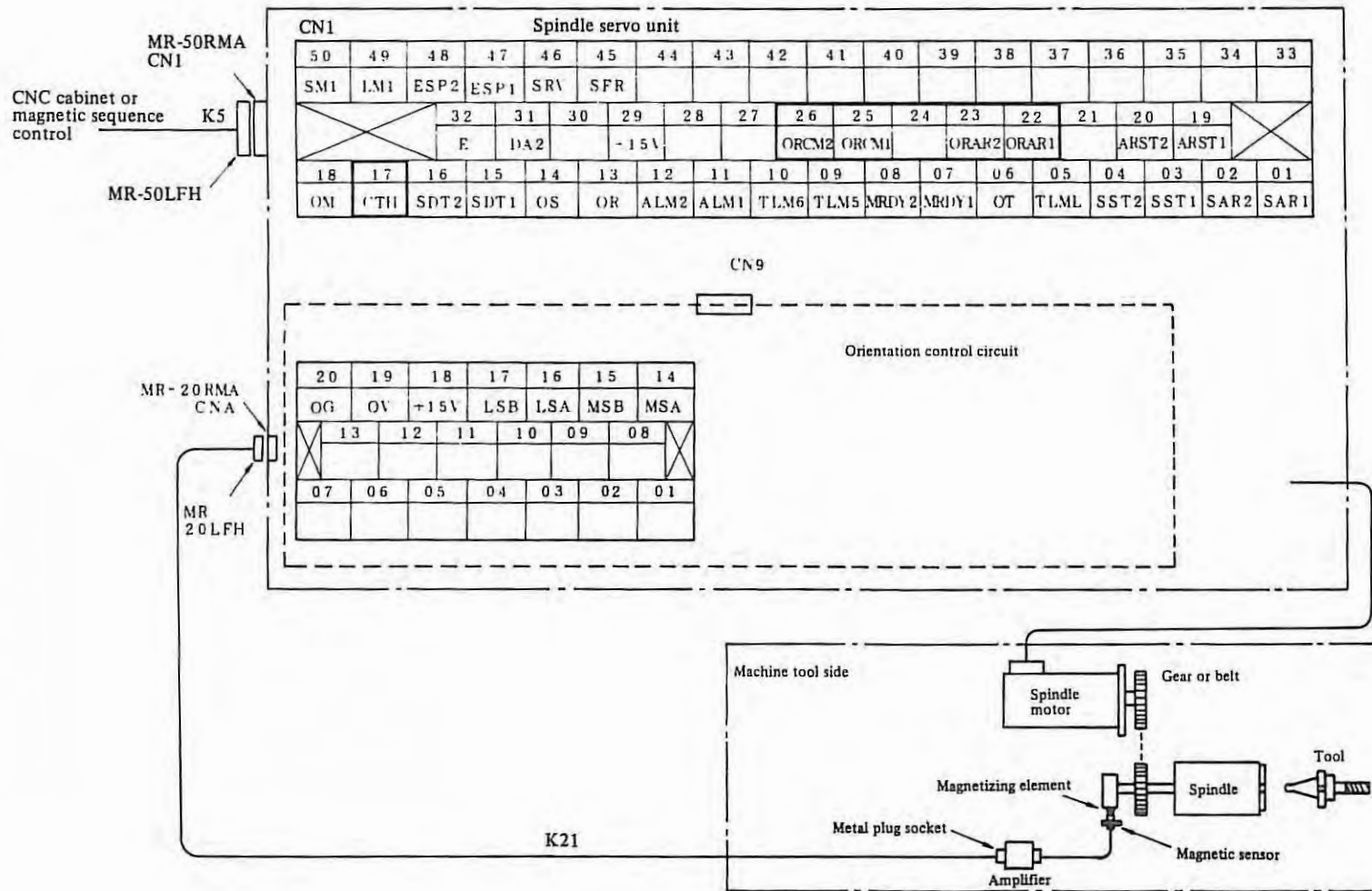
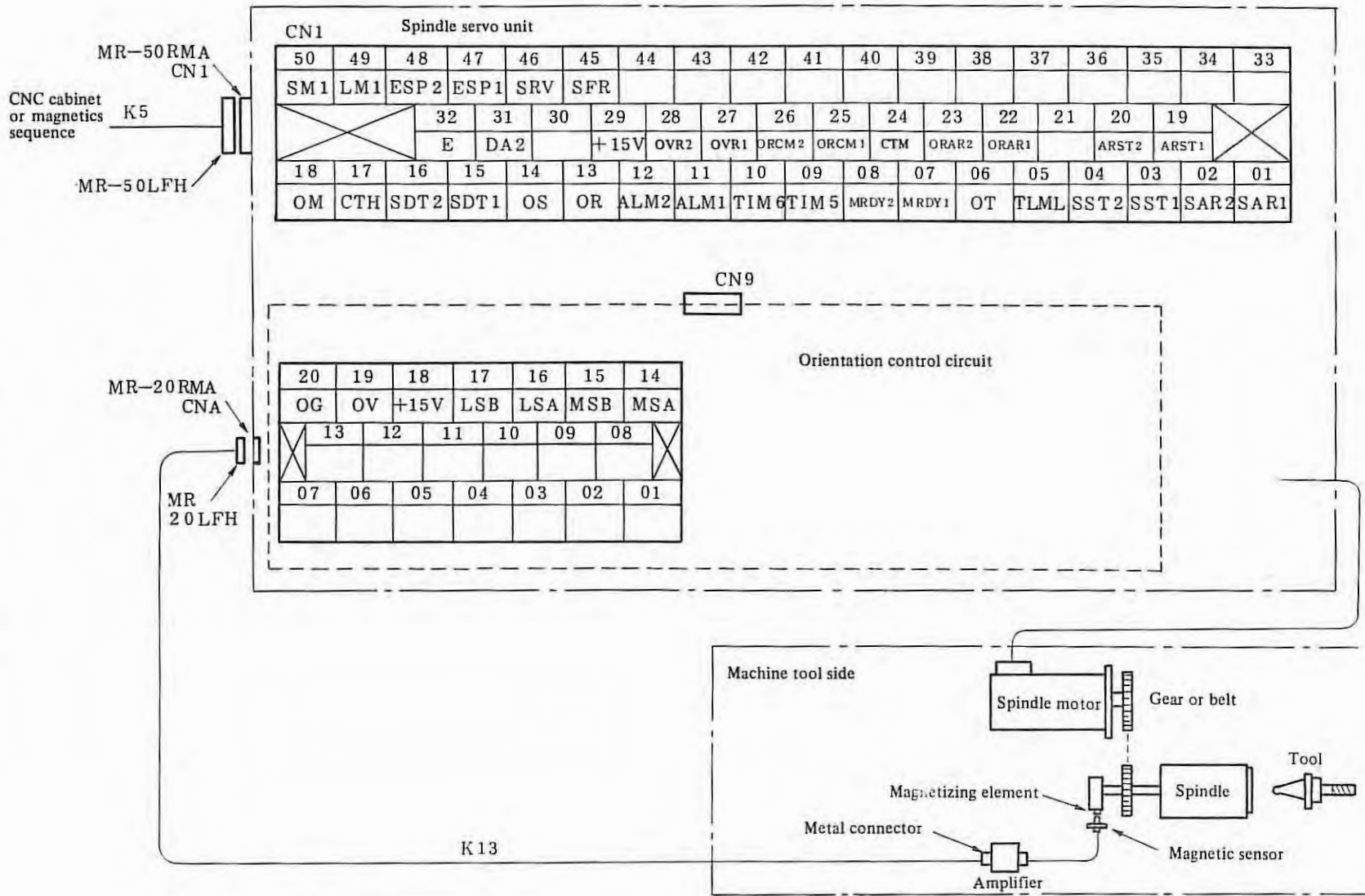
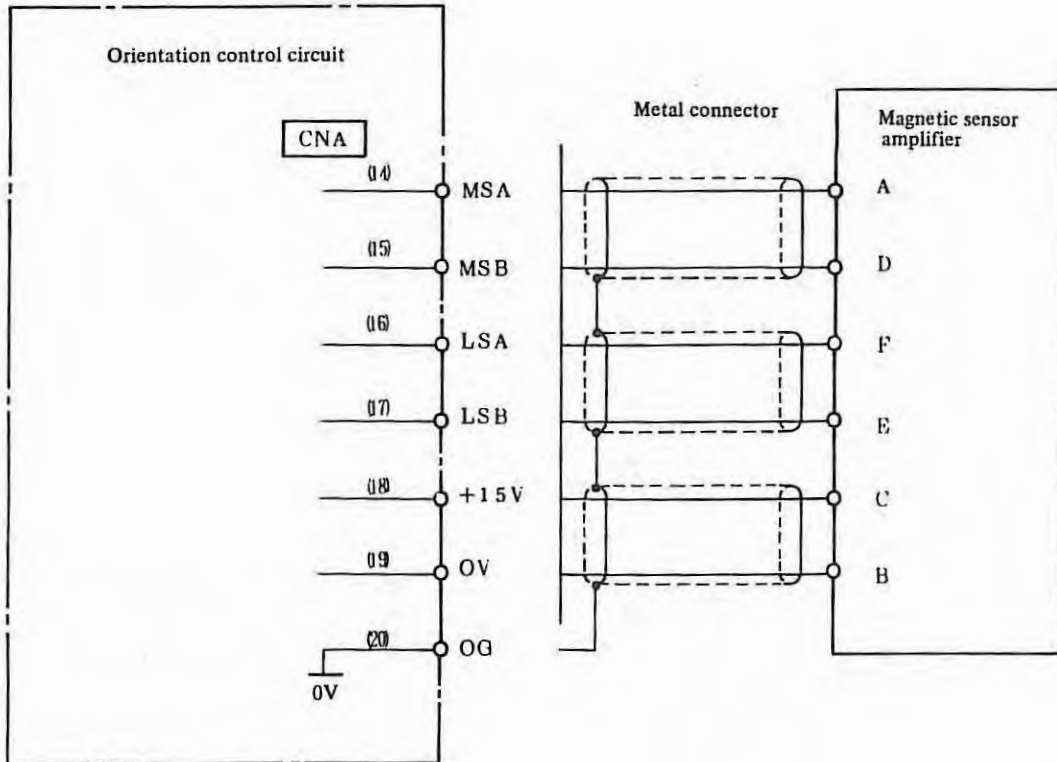

Fig. 1 (j) Spindle orientation connection diagram (models 6S - 22S with magnetic sensor)





Note) The cable length should be shorter than 20 m between the servo unit and the magnetic sensor amplifier.

Fig. 1 (k) Spindle orientation connection diagram using magnetic sensor

APPENDIX 2 CABLE ROUTING

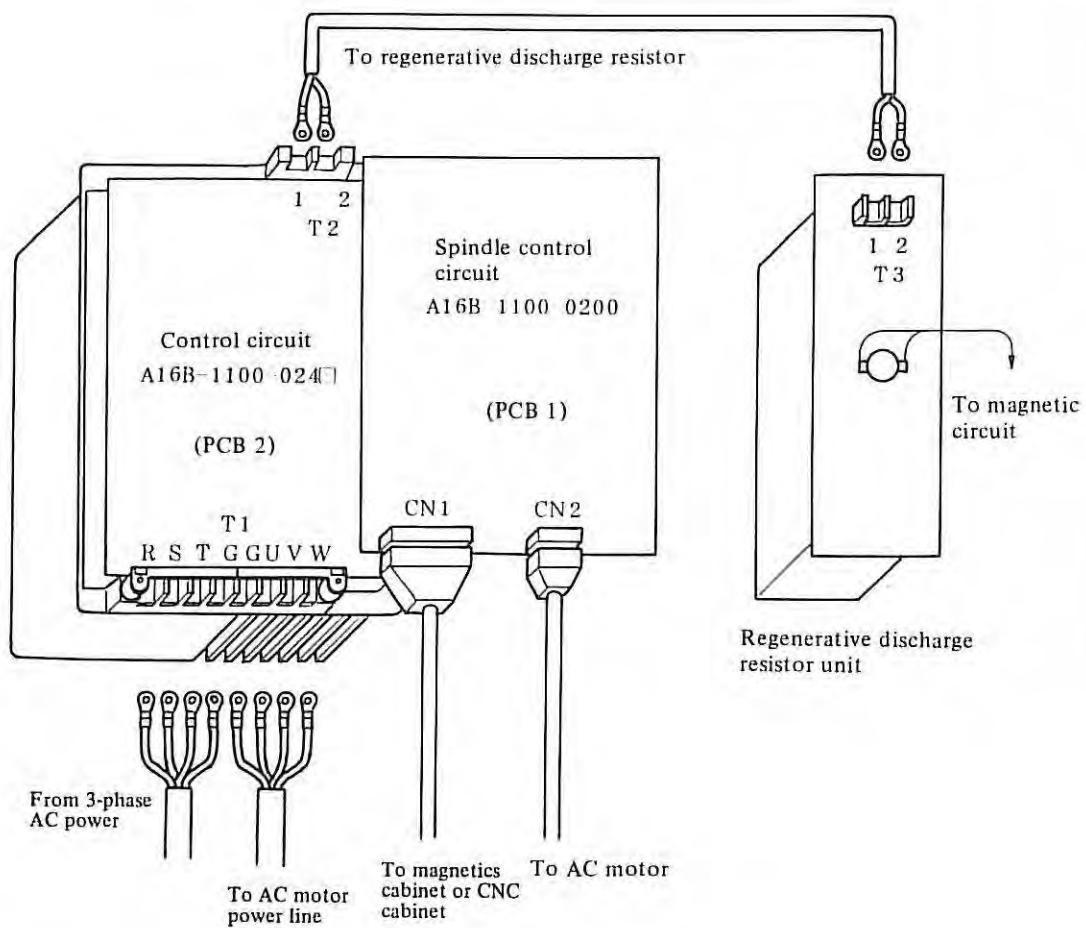

Fig. 2 (a) Cable routing (models 1S - 3S)

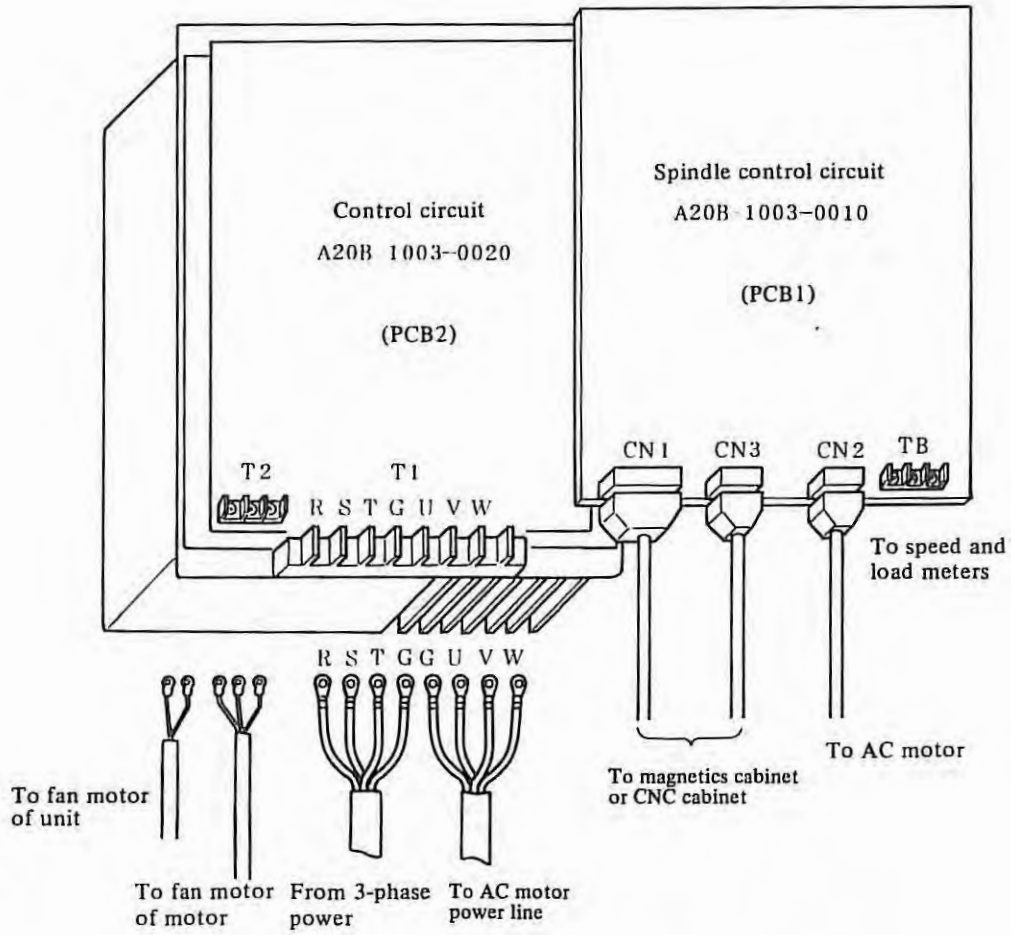

Fig. 2 (b) Cable routing (models 6S - 12S)

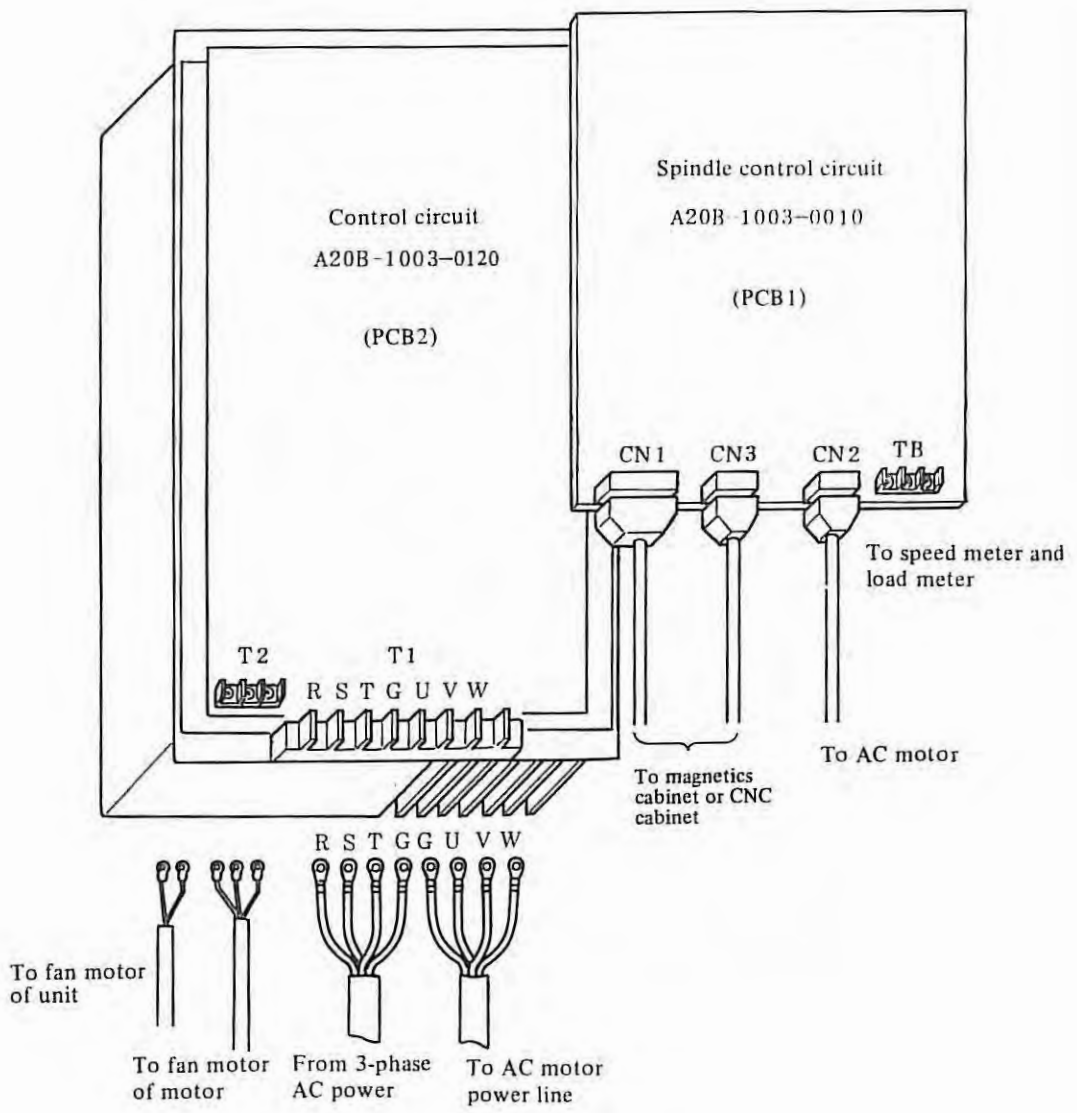

Fig. 2 (c) Cable routing (models 15S - 22S)

APPENDIX 3 CABLE SPECIFICATIONS

The cable specifications are as shown below. Cables are provided by the MTB.

1) Power and drive lines

Model	Symbol	Specifications	FANUC specification No.
1S (Lower than 5 kVA)	K1 K2	<p>Cabtyre cable JIS C 3312 4 conductors</p> <p>37/0.26 (2.0mm²)</p> <p>12.0 φ</p> <p>Crimp style terminals T2-4</p>	A06B-6052-K201 7 m
1.5S, 2S (Lower than 7 kVA)	K1 K2	<p>Cabtyre cable JIS C 3312 4 conductors</p> <p>45/0.32 (3.5mm²)</p> <p>14.0 φ</p> <p>Crimp style terminals T5.5-4</p>	A06B-6052-K202 7 m
3S (Lower than 12 kVA)	K1 K2	<p>Cabtyre cable JIS C 3312 4 conductors</p> <p>70/0.32 (5.5mm²)</p> <p>15.5 φ</p> <p>16.5 φ</p> <p>Crimp style terminals T5.5-6</p>	A02B-0008-K853 7 m
6S (Lower than 16 kVA)	K1 K2	<p>Cabtyre cable JIS C 3312 4 conductors</p> <p>50/0.45 (8mm²)</p> <p>20 φ</p> <p>Crimp style terminals 8-6</p>	A02B-0008-K854 7 m
8S, 12S (Lower than 25 kVA)	K1	<p>Cabtyre cable JIS C 3312 4 conductors</p> <p>88/0.45 (14mm²)</p> <p>24 φ</p> <p>Crimp style terminals 14-6 (K2: Drive line) 14-8 (K1: Power line)</p>	A06B-6044-K017 7 m
	K2		A06B-6044-K018 7 m

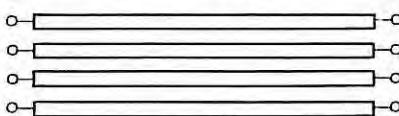
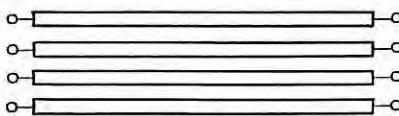
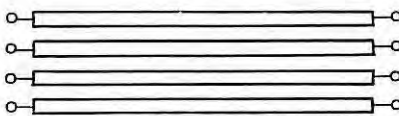
Model	Symbol	Specifications	FANUC specification No.
15S (Lower than 30 kVA)	K1 K2	<p style="text-align: center;">Heat resisting vinyl cable</p>  <p style="text-align: center;">Crimp style terminal 14 - 8 7/20/0.45 (14 mm²) Crimp style terminal R14-6S</p>	A06B-6044-K019 7 m
18S (Lower than 45 kVA)	K1 K2	<p style="text-align: center;">Heat resisting vinyl cable</p>  <p style="text-align: center;">Crimp style terminal 20 - 8 (Note) 7/27/0.45 (20 mm²) Crimp style terminal 20 - 8</p>	
22S (Lower than 45 kVA)	K1 K2	<p style="text-align: center;">Heat resisting vinyl cable</p>  <p style="text-align: center;">Crimp style terminal 30 - 8 7/27/0.45 (30 mm²) Crimp style terminal 30 - 8</p>	

Note) Use the flame retardant poli-flex cable (MLFC)
(Maximum temperature of conductor: 105°C)

APPENDIX 4 CONFIGURATION OF SPINDLE CIRCUIT

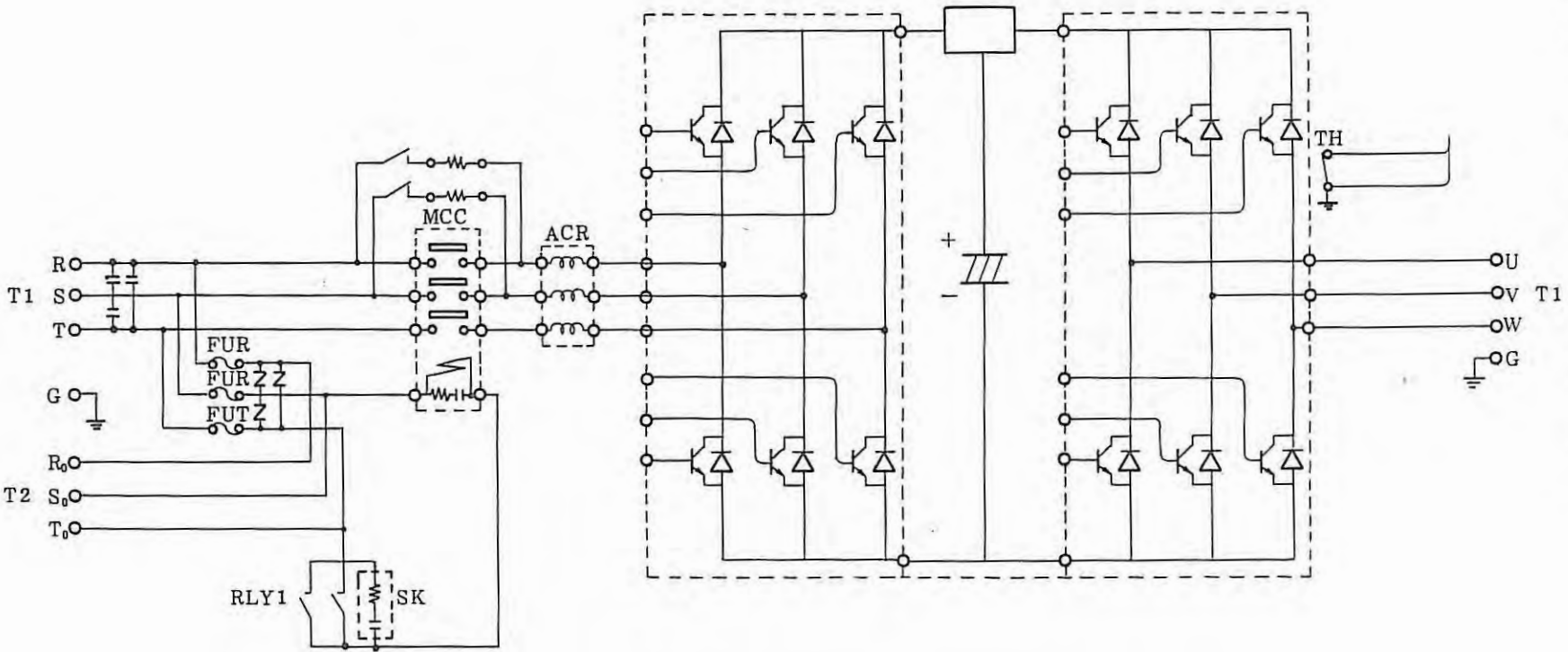

APPENDIX 5 LOCATION OF UNIT

1) Unit (models 1S - 3S)

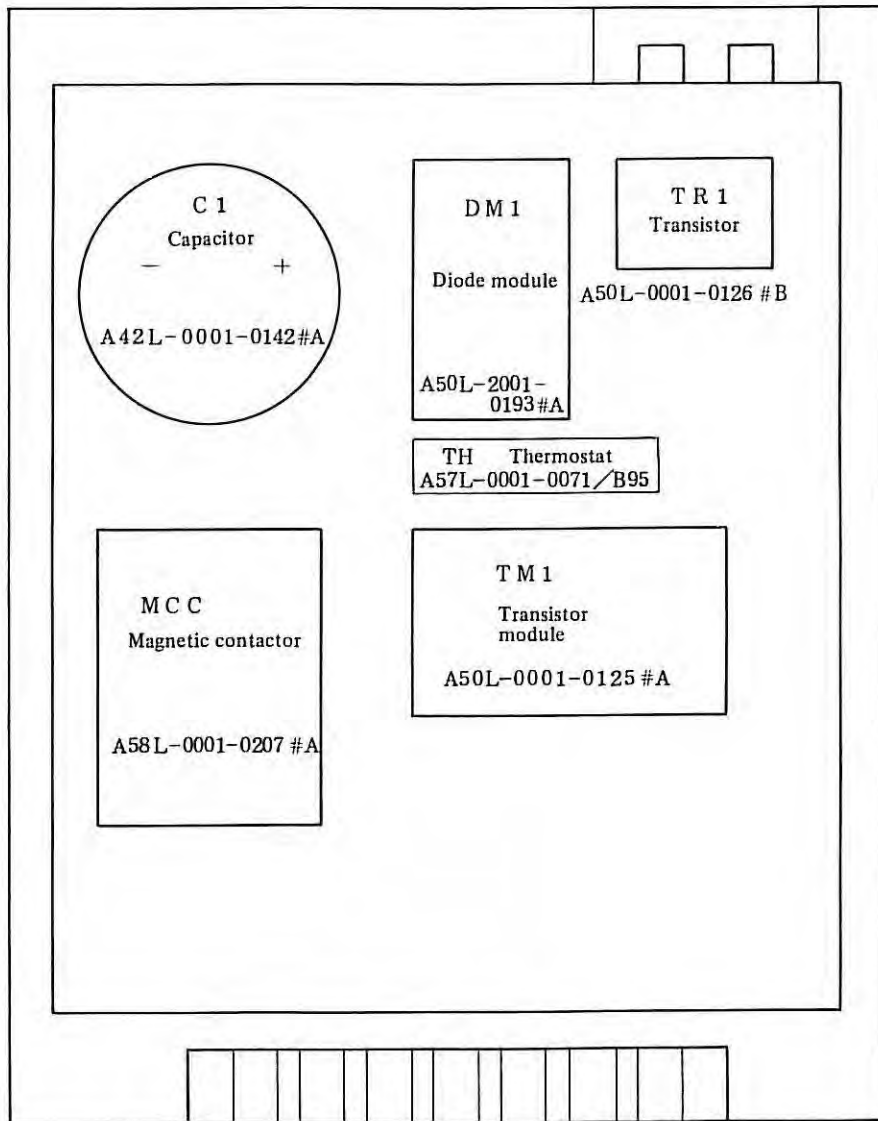

Heat sink A50L-6001-0347

Spindle control circuit PCB (PCB1): A16B-1100-0200
 Control circuit PCB (PCB2) : A16B-1100-024□

See Fig. 2 (a) in Appendix 2.

2) Unit (models 6S - 12S)

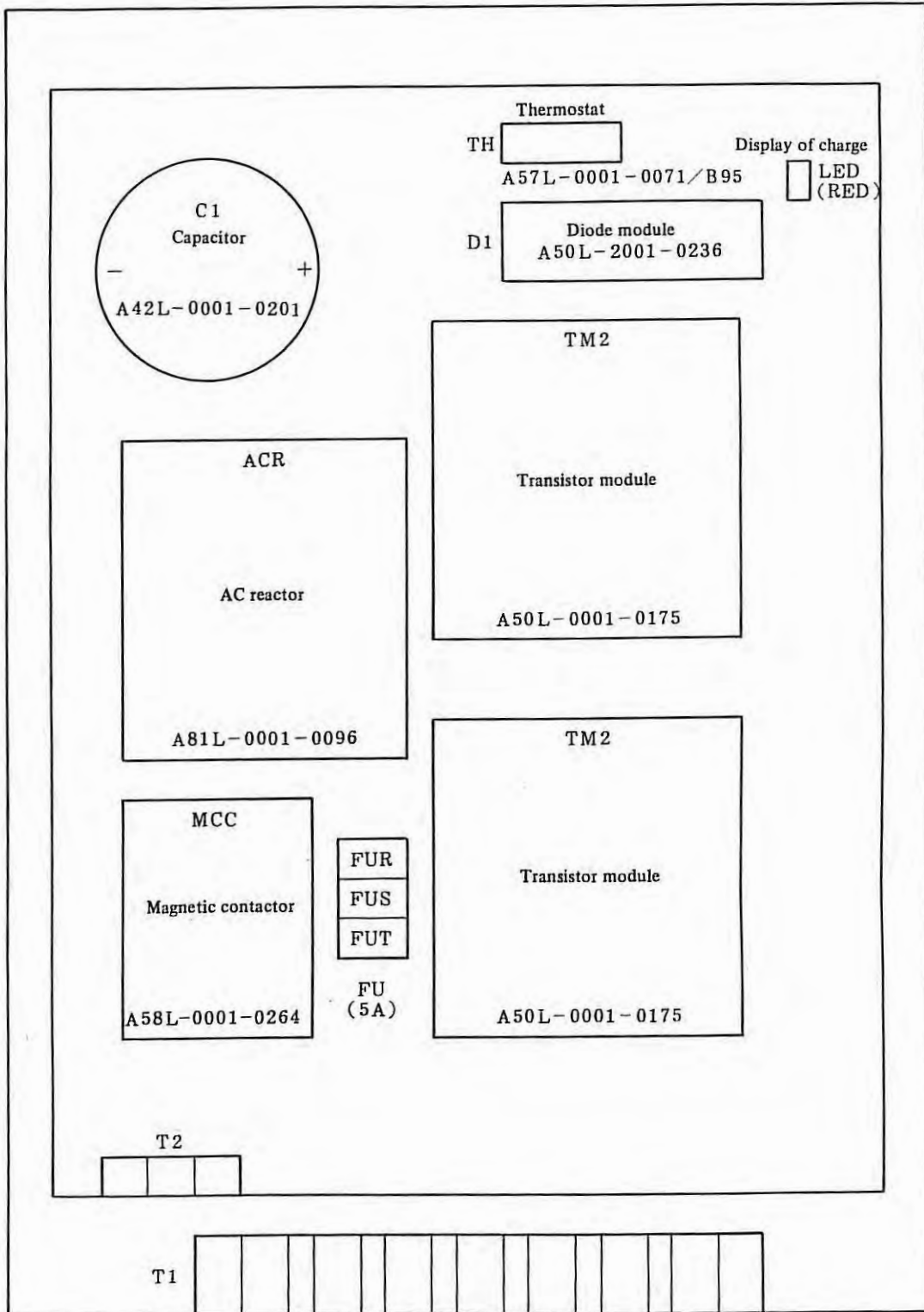

Spindle control circuit PCB (PCB1): A20B-1003-0010
 Control circuit PCB (PCB2) : A20B-1003-0020

See Fig. 2 (b) in Appendix 2.

3) Unit (models 15S - 22S)

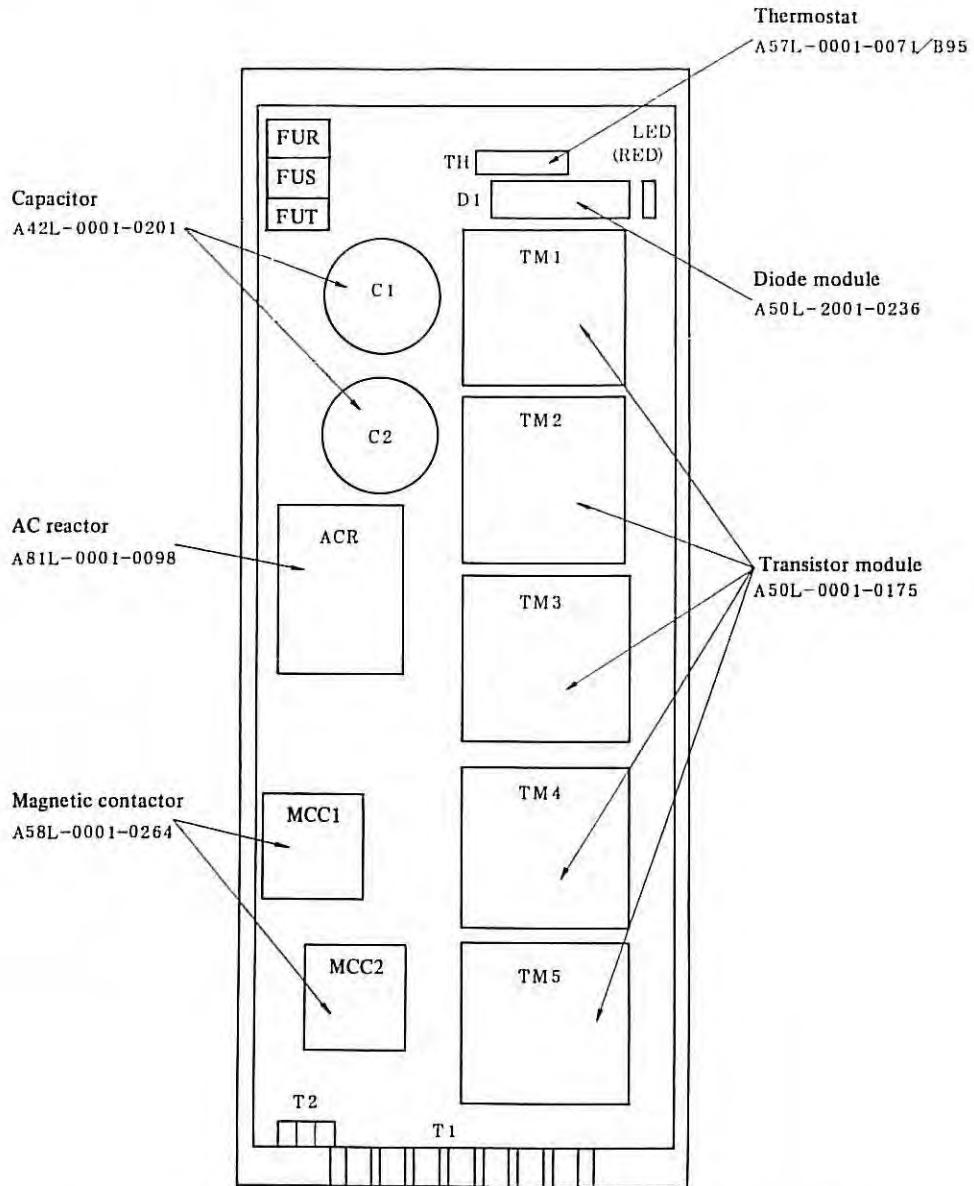

Spindle control circuit PCB (PCB1): A20B-1003-0010
 Control circuit PCB (PCB2) : A20B-1003-0120

See Fig. 2 (c) in Appendix 2.

APPENDIX 6 LOCATION OF PCB

1) Models 1S - 3S

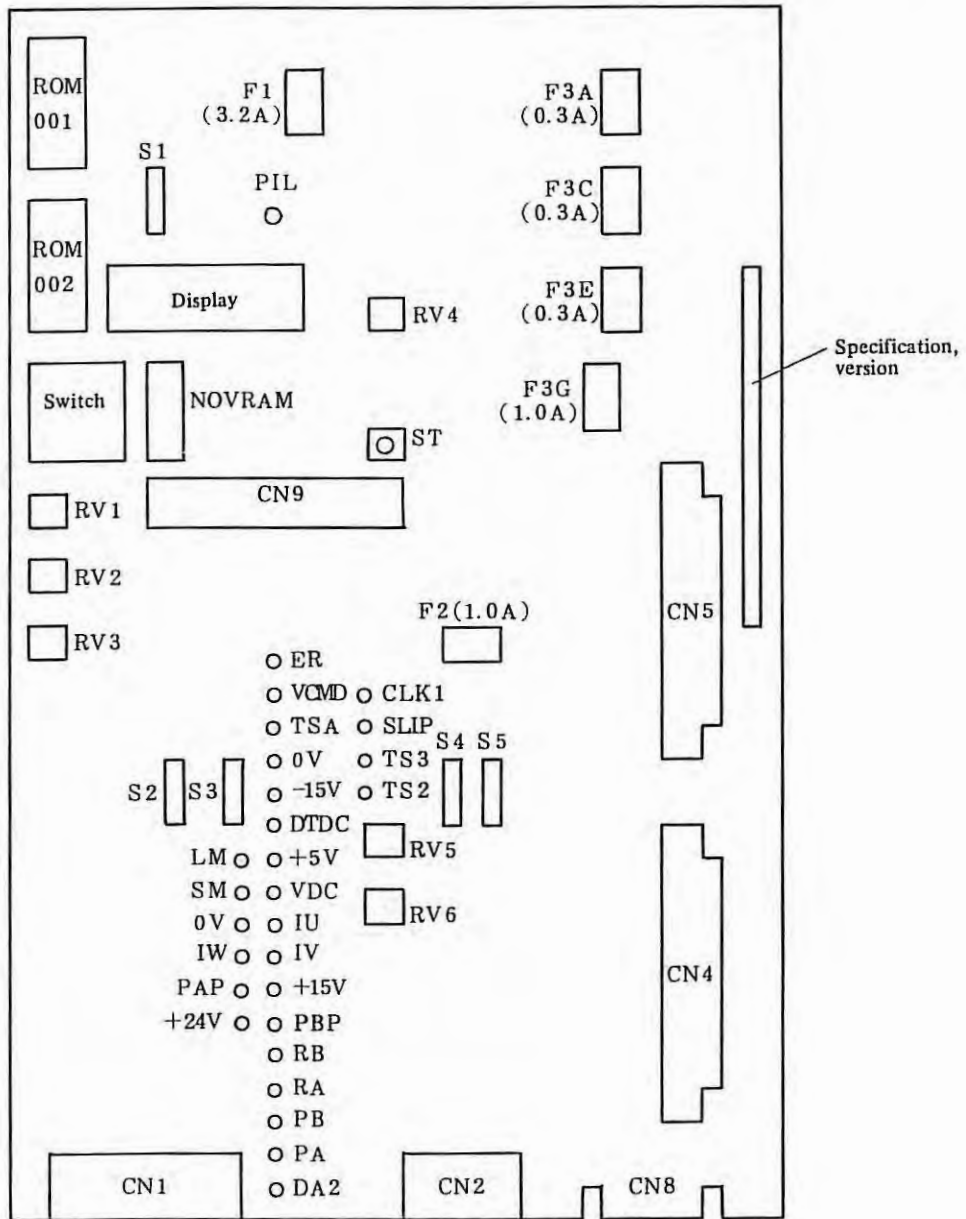

2) Models 6S - 22S

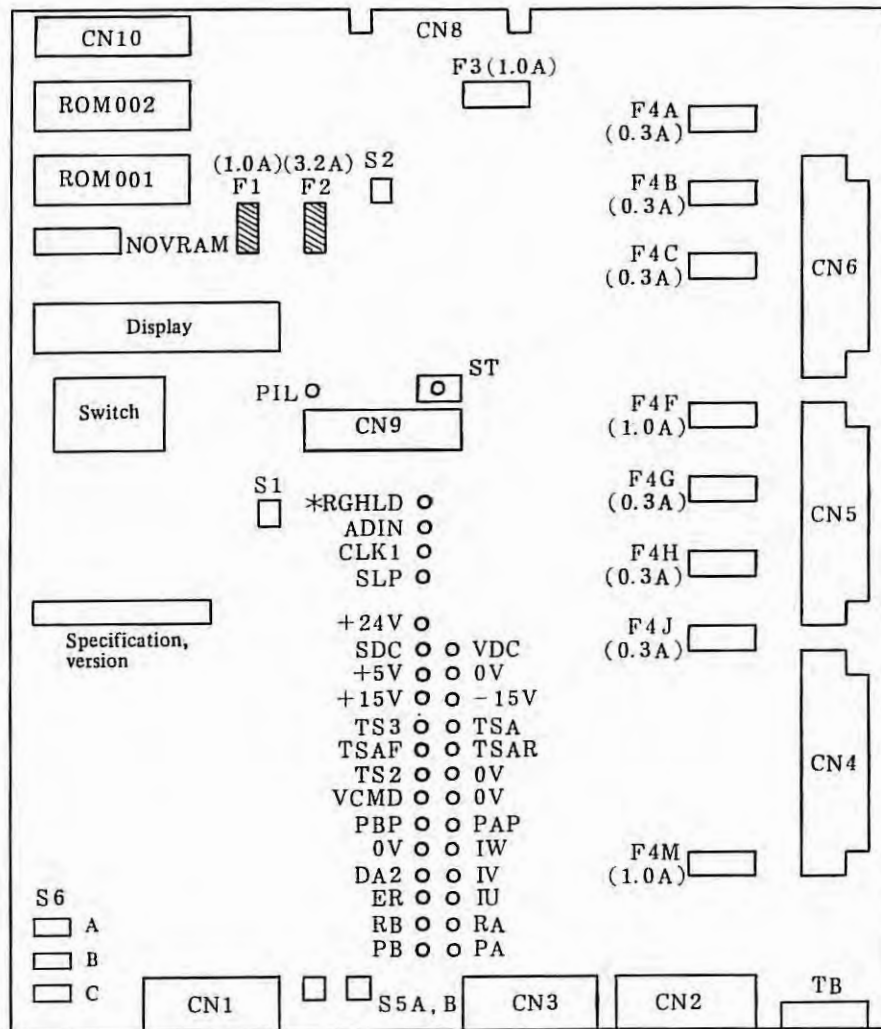

APPENDIX 7 MAJOR PARTS

1) Models 1S - 3S

Name	Symbol	Specifications	Remarks
Spindle control circuit PCB	PCB1	A16B-1100-0200	
Fuse	F1	A60L-0001-0175/3.2A	3.2A
	F2, F3G	A60L-0001-0175/1.0A	1.0A
	F3A, C, E	A60L-0001-0175/0.3A	0.3A
Control circuit PCB	PCB2	A16B-1100-024	
Transistor module	TM1	A50L-0001-0125#A	50A/600Vx6
Transistor	TR1	A50L-0001-0126#B	50A/600Vx1
Diode module	DM1	A50L-2001-0193#A	
Magnetic contactor	MCC	A58L-0001-0207#A	
Capacitor	C1	A42L-0001-0142#A	
Thermostat	TH	A57L-0001-0071/B95	
AC line filter		A81L-0001-0083/3C	option

2) Models 6S - 22S

Name	Symbol	Specifications	Remarks
Spindle control circuit PCB	PCB1	A20B-1003-0010	
Alarm fuse	F1	A60L-0001-0046/1.0	1.0A
	F2	A60L-0001-0046/3.2	3.2A
Fuse	F3, F4M, F4F	A60L-0001-0175/1.0A	1.0A
	F4A, B, C, G, H, J	A60L-0001-0175/0.3A	0.3A
Control circuit PCB	PCB2	A20B-1003-0020	Models 6S - 12S
		A20B-1003-0120	Models 15S - 22S
Fuse	FUR, S, T	A60L-0001-0031/5A	5.0A
Transistor module	TM1 - 5	A50L-0001-0175	120A/600Vx6
Diode module	D1	A50L-2001-0236	
Magnetic contactor	MCC	A58L-0001-0264	
Capacitor	C1, 2	A42L-0001-0201	
Surge absorber		A50L-2001-0155/ 20D431	
Thermostat	TH	A57L-0001-0071/B95	
AC reactor	ACR	A81L-0001-0096	Models 6S - 12S
	ACR	A81L-0001-0098	Models 15S - 22S
Terminal cover		A300-0001-X088	Models 6S - 22S (basic)

APPENDIX 8 MAGNETIC SENSOR SIGNALS CHECKING METHOD

8.1 Application

This document applies to the following check procedure by observing output signals of the magnetic sensor (specification: A57L-0001-0037) employed for magnetic sensor system spindle orientation.

Item	Check item
1	Whether magnetizer, magnetic sensor head, and magnetic sensor amplifier are defective or not.
2	Whether magnetizer and magnetic sensor head are properly mounted or not;
3	Whether magnetic sensor signal cables are properly connected without any connection failure and short-circuit.

8.2 Check Procedure

1) Preparation

- ① Rotate the spindle at about 120rpm. Select the counterclockwise rotating direction as viewed from the AC spindle motor shaft (in such a direction as the voltage at the test point (VCMD) of AC spindle control circuit PCB becomes positive against 0 V.
Models 1S - 3S : A16B-1100-0200
Models 6S - 22S: A20B-1003-0010
- ② Check the peak voltage and offset voltage levels of the following signal waveforms at the test points of the orientation circuit (A20B-0008-0030 to 1 or A20B-0009-0520) using an oscilloscope. The names of test points and signal contents are common, irrespective of the kinds of orientation circuit.

Test points	Signal name	Symbol	Prove common terminal
CH1	Magnetic sensor output signal A	MSA	0 V
CH2	Magnetic sensor output signal B	LSA	

APPENDIX 9 PARAMETER LIST

Note) Parameters made with * are used for models 6S - 22S.

Mode	Contents		Standard setting	Data	
F-00	Display of rotation number of motor				
F-01	Use/non-use of machine ready signal (MRDY)	Use : 1	1		
		Non-use: 1			
F-02 *	Use/non-use of override function	Use : 1	1		
		Non-use: 1			
F-03 *	Setting of override range	- 120% : 1	1		
		- 100% : 0			
F-05 *	Setting of maximum speed		Depends upon the motor specification		
	Standard specification	High speed specification			Setting
	- 5000 rpm	- 10000 rpm			0
	- 6000 rpm	- 12000 rpm			1
		- 15000 rpm			2
	- 20000 rpm	3			
F-06	Pattern setting of output limit		0		
	Contents	Setting			
		Pattern 1			Pattern 2
	No output limiting made	0			0
	Output limit is made only at acceleration/deceleration	1			4
Output limit is made only at normal rotation, not at acceleration/deceleration	2	5			
Output limit is made for all operations	3	6			
F-07	Setting of limit value at Rated maximum output is 100 output limit		100		
F-08	Setting of delay time before shut-off of motor power Delay time = (Set value) x 40 msec.		5		

Mode	Contents	Standard setting	Data
F-09	Use/non-use of shut-off of motor power by machine ready signal (MRDY)	Use : 1	0
		Non-use: 0	
F-10	Velocity deviation offset adjustment at forward rotation command (SFR)	128	
F-11	Velocity deviation offset adjustment at reverse rotation command (SRV)	128	
F-12	Velocity deviation offset adjustment at orientation command (OCR)	128	
F-13	Rotation number adjustment at forward rotation	Depends upon models	
F-14	Rotation number adjustment at reverse rotation		
F-15	Rotation number at velocity command voltage, 10 V Rotation number = (Set value) x 100 rpm		
F-16	Detection range of velocity arrival signal Detection range = Within +(Set value)% of command rotation number	15	
F-17	Detection level of velocity detection signal Detection range = Less than (Set value)% of maximum rotation number	3	
F-18	Setting of torque limit value Torque limit value = Less than (Set value)% of maximum output	50	
F-19	Setting of time needed for acceleration/deceleration Set value = (Acceleration time, sec) x 2	10	
F-20	Limiting of regenerated power (Adjustment of deceleration time) Setting range = 0 - 100	60	
F-21	Setting of velocity control phase compensation P: HIGH gear (CTH = 1)	50	
F-22	Setting of velocity control phase compensation P: LOW gear (CTH = 0)	50	
F-23	Setting of velocity control phase compensation P at orientation: HIGH gear	100	
F-24	Setting of velocity control phase compensation P at orientation: LOW gear	100	
F-25	Setting of velocity control phase compensation I: HIGH gear (CTH = 1)	30	

Mode	Contents	Standard setting	Data
F-26	Setting of velocity control phase compensation I: LOW gear (CTH = 0)	30	
F-27	Setting of velocity control phase compensation I at orientation: HIGH gear	30	
F-28	Setting of velocity control phase compensation I at orientation: LOW gear	30	
F-29 *	Adjustment of velocity detection offset (adjusted at shipping)	Approx. 128	
F-31	Setting of rigid tap mode	0	
F-32	Setting of normal motor voltage	10	
F-33	Setting of motor voltage at orientation	10	
F-34	Setting of motor voltage at rigid tap mode	100	
F-35	Setting of zero speed signal detection level	75	
F-36	Setting of load detection level	90	
F-37 *	Time constant of torque change at deceleration	0	
F-38 *	Setting of control characteristics at deceleration	0	
F-39 *	Setting of control characteristics at stable rotation with no load	0	
F-40 *	Setting of control characteristics at torque limit	0	

Revision Record

AC SPINDLE SERVO UNIT S series MAINTENANCE MANUAL (B-65015E)

01	'87, 11	_____			
Edition	Date	Contents	Edition	Date	Contents

- *No part of this manual may be reproduced in any form.*
- *All specifications and designs are subject to change without notice.*