

# **Tandon**

**TM501, TM502, TM503**

**RIGID DISK DRIVES**

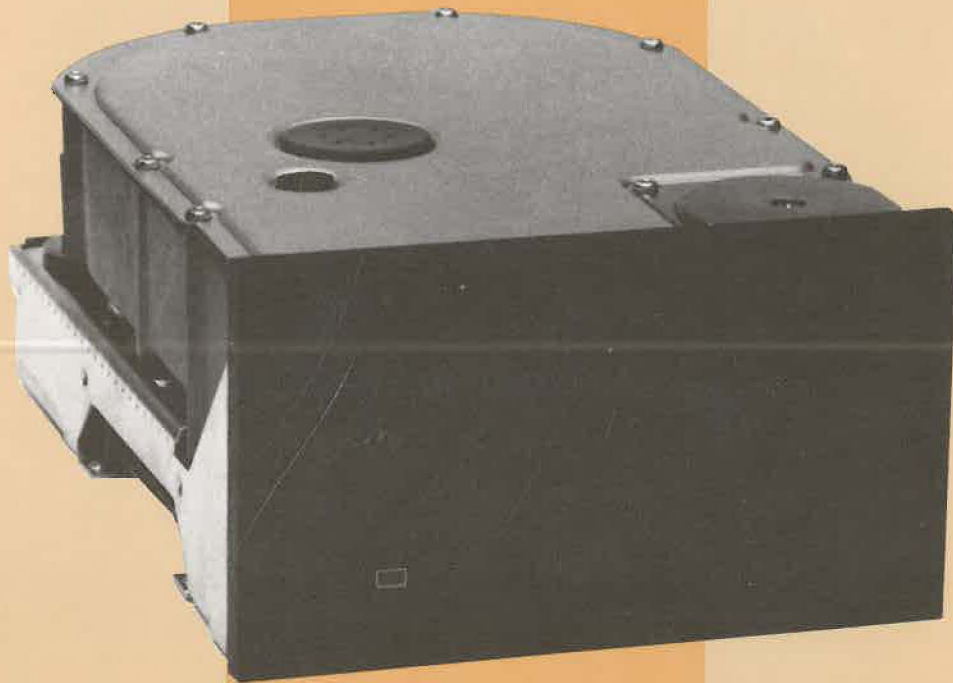

**PRODUCT SPECIFICATION AND USER'S MANUAL**

TM501, TM502, TM503  
345 TRACKS PER INCH  
PRODUCT SPECIFICATION AND USER'S MANUAL

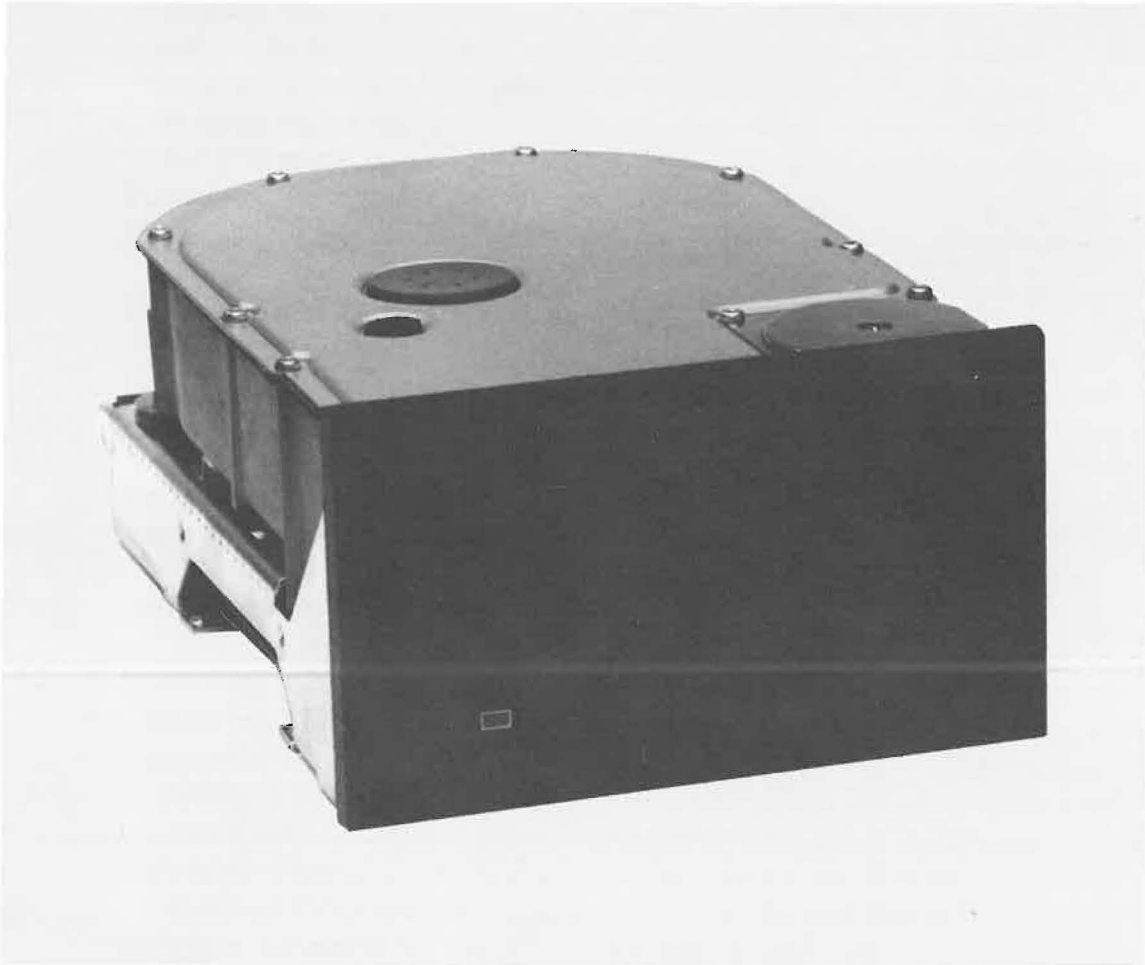

**Tandon** CORPORATION  
20320 PRAIRIE STREET  
CHATSWORTH, CALIFORNIA 91311

© COPYRIGHT 1983 TANDON CORPORATION

# CONTENTS

Section Number	Title	Page Number
SECTION 1	GENERAL DESCRIPTION	
	Introduction.....	1-1
1.1	Scope Of The Document.....	1-1
1.2	Purpose Of The Drive.....	1-1
1.3	Major Features.....	1-1
	Microprocessor Control.....	1-1
	Daisy Chain Capability.....	1-1
	Industry Standard Interface Compatibility.....	1-1
	Activity Indicator.....	1-2
	Air Filtration.....	1-2
1.4	Functional Description.....	1-2
1.5	Physical Description.....	1-2
SECTION 2	PRODUCT SPECIFICATIONS	
	Introduction.....	2-1
2.1	Mechanical Specifications.....	2-1
2.2	Electrical and Operational Specifications.....	2-1
2.3	Reliability Specifications.....	2-1
2.4	Environmental Specifications.....	2-1
SECTION 3	OPERATION	
	Introduction.....	3-1
3.1	Unpacking The Drive.....	3-1
3.2	Preinstallation Checkout.....	3-1
3.3	Mounting The Drive.....	3-1
	Dust Cover.....	3-3
	Free Air Flow.....	3-3
	Confined Environment.....	3-3
3.4	Interface Connectors.....	3-3
	J1/P1 Connector.....	3-3
	J2/P2 Connector.....	3-3
	J3/P3 Connector.....	3-6
	Frame Ground Connector.....	3-6
3.5	Interface Line Descriptions.....	3-6
	Input Control Signals.....	3-6
	Output Control Signals.....	3-12
	Data Transfer Signals.....	3-13
3.6	Drive Address and Option Selection.....	3-14
3.7	Shipping Pack and Handling.....	3-14

## ILLUSTRATIONS

### FIGURES

<b>Figure Number</b>	<b>Title</b>	<b>Page Number</b>
1-1	Disk Drive.....	1-2
2-1	Disk Drive Outline Drawing.....	2-2
2-2	Typical Starting Currents.....	2-5
3-1	Four Pack Shipping Container.....	3-2
3-2	J1 Edge Connector Dimensions.....	3-4
3-3	J2 Edge Connector Dimensions.....	3-4
3-4	J3 Power Connector.....	3-4
3-5	Radial Configuration.....	3-7
3-6	Daisy Chain Control Lines.....	3-8
3-7	Control Signal/Driver Receiver Circuit Combination.....	3-9
3-8	Step Mode Timing.....	3-11
3-9	Buffered Seek Step Pulses.....	3-11
3-10	Data Transfer Line Driver Receiver.....	3-13
3-11	Recommended Shipping Pack Design, Configuration 1.....	3-16
3-12	Recommended Shipping Pack Design, Configuration 2.....	3-18
3-13	Recommended Shipping Pack Design, Configuration 3.....	3-19
3-14	Load Graph.....	3-21

### TABLES

<b>Table Number</b>	<b>Title</b>	<b>Page Number</b>
2-1	Electrical and Operational Specifications.....	2-3
2-2	Reliability Specifications.....	2-6
2-3	Environmental Specifications.....	2-7
3-1	Drive Interface Signals and Pin Assignments.....	3-5
3-2	Head Select Lines.....	3-10
3-3	Option Programming Guide.....	3-15



# SECTION 1

## GENERAL DESCRIPTION

### INTRODUCTION

This manual provides useful information to assist the customer when incorporating the Tandon rigid disk drive into a system.

Tandon Corporation's TM500 series of drives are full feature, 5-1/4-inch, rigid disk drives. They are compact data storage devices that contain one or more 130-millimeter plated aluminum platters within a sealed housing.

The TM500 series includes Model Numbers TM501, TM502, and TM503, which have one, two, and three recording platters, and use two, four, and six recording heads, respectively.

#### 1.1 SCOPE OF THE DOCUMENT

Section 1 of this manual contains a general description of the disk drives. Section 2 contains the product specifications. Section 3 provides information on operation of the drives.

#### 1.2 PURPOSE OF THE DRIVE

The 5-1/4-inch disk drive is a rotating disk memory device designed for random access data storage and retrieval. Typical applications include word processing systems, entry level microprocessor systems, intelligent calculators, program storage, small business computer systems, and any application in which low cost, random access data storage is required.

#### 1.3 MAJOR FEATURES

##### MICROPROCESSOR CONTROL

The TM500 series of drives feature an onboard microprocessor. The microprocessor provides five major functions:

1. Self-calibration on power-up.
2. Buffered seek timing for improved access times.
3. Improved positioning with reduced hysteresis.
4. Write current switching for optimal recording quality.
5. Power and track fault detection.

##### DAISY CHAIN CAPABILITY

The drive provides the address selection and gating functions necessary to daisy chain a maximum of four units at the user's option. The last drive on the daisy chain terminates the interface. The terminations are accomplished by a resistor array plugged into a DIP socket.

##### INDUSTRY STANDARD INTERFACE COMPATIBILITY

The drive is compatible with controllers that use an industry standard interface.

## ACTIVITY INDICATOR

The activity indicator is located on the front panel of the drive. It is automatically illuminated when the drive is selected.

## AIR FILTRATION

A self-contained, recirculating air filtration system supplies clean air through a 0.3-micron filter. A secondary absolute filter is provided to allow pressure equalization with the ambient atmosphere without contamination. The entire head-disk-actuator compartment is maintained at a slightly positive pressure to further ensure an ultraclean environment.

## 1.4 FUNCTIONAL DESCRIPTION

The drive is fully self-contained and requires no operator intervention during normal operation. During the power-up sequence, the spindle motor reaches 3600 RPM, and the positioning mechanism recalibrates the recording heads back to Track 0. At this time, a Ready signal on the interface indicates the drive is ready for operation.

The head is positioned over the desired track by means of a four-phase stepper motor/band assembly and its associated electronics. This positioner uses a one-step rotation to cause a one-track radial movement. Subsequently, the recording heads can be positioned over the desired cylinders, and the data can be read or written from the appropriate track by selecting the desired head.

Typically, the drive uses MFM write and read data recording methods. Data recovery electronics include a low-level read amplifier, differentiator, a zero-crossover detector, and digitizing circuits. No data decoding feature is provided on the drives.

The drive has the following sensor systems:

1. An optical Track 0 switch senses when the Head/Carriage Assembly is positioned at Track 0.

2. An index sensor, which consists of a magnetic pick-up and index hole positioned to provide an analog signal when an index hole is detected.

## 1.5 PHYSICAL DESCRIPTION

The TM500 drive is shown in Figure 1-1. The drives contain 130 millimeter storage media that rotate at 3600 RPM, using a direct drive, brushless D. C. motor. The recording is accomplished by noncontact standard recording heads that are moved by a precision split band positioning device and stepper motor.

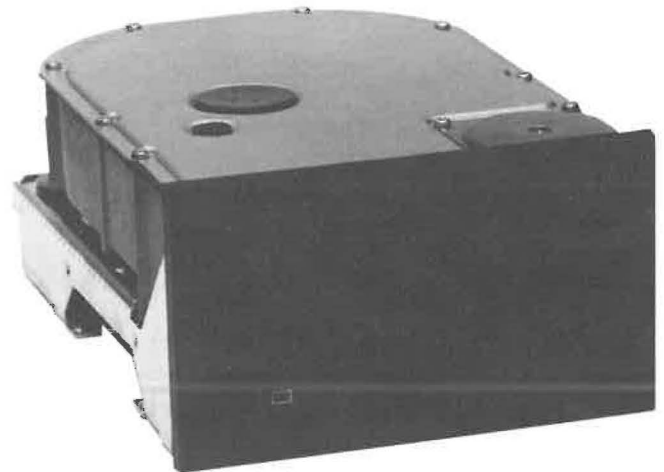

**FIGURE 1-1  
DISK DRIVE**

The Head Disk Assembly is enclosed in a sealed cast aluminum housing, which includes an air filtration system to ensure a contamination-free environment. The housing is shock mounted to a metal frame that has the front panel attached, and threaded holes on the sides and bottom for mounting the drive onto a chassis.

In addition, the drive includes the read/write control electronics, the servo spindle control electronics, an index sensor, a brake assembly, and a front panel indicator.

# SECTION 2

## PRODUCT SPECIFICATIONS

### INTRODUCTION

This section contains the mechanical, electrical and operational, reliability, and environmental specifications for the TM501, TM502, and TM503 disk drives.

#### 2.1 MECHANICAL SPECIFICATIONS

The mechanical and physical dimensions are contained in Figure 2-1.

#### 2.2 ELECTRICAL AND OPERATIONAL SPECIFICATIONS

The electrical and operational specifications are contained in Table 2-1. Typical starting current requirements at nominal voltage are contained in Figure 2-2.

#### 2.3 RELIABILITY SPECIFICATIONS

The reliability specifications are contained in Table 2-2.

#### 2.4 ENVIRONMENTAL SPECIFICATIONS

The environmental specifications are contained in Table 2-3.

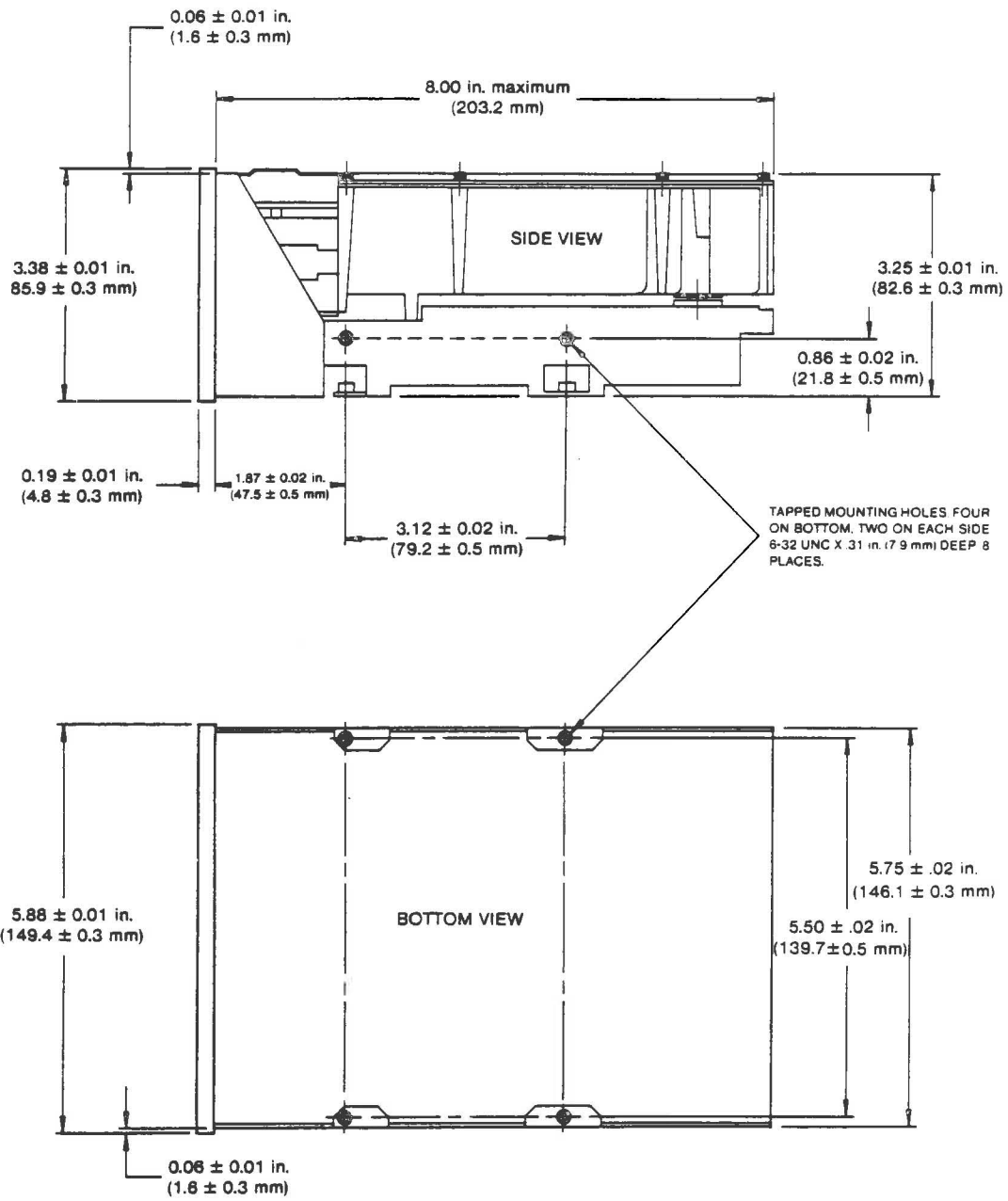

Note: Weight is 3.0 kilograms, 6.5 pounds maximum

**FIGURE 2-1  
DISK DRIVE OUTLINE DRAWING**

**TABLE 2-1  
ELECTRICAL AND OPERATIONAL SPECIFICATIONS**

Media	Lubricated, 130 millimeter, plated aluminum disk
Tracks Per Inch	345 TPI
Spacing, Track to Track	2.9 milinches
Number of Cylinders	306 cylinders
Number of Tracks	
TM501	612 tracks
TM502	1224 tracks
TM503	1836 tracks
Disk Speed	3600 RPM $\pm$ 1 percent
Average Latency	8.33 milliseconds
Start Time	15 seconds maximum
Stop Time	15 seconds maximum
Seek Time	3 milliseconds track to track
Head Settling Time	15 milliseconds, last track accessed
Average Access Time, Including Head Settling Time, 3 Millisecond Step Rate	321 milliseconds
Average Access Time Using Buffered Seek, Including Head Settling Time	85 milliseconds
Transfer Rate	5 megabits per second

**TABLE 2-1 (CONTINUED)  
ELECTRICAL AND OPERATIONAL SPECIFICATIONS**

Maximum Flux Reversal Density	9090 FRPI
Unformatted Capacity Per Drive	
TM501	6.38 megabytes
TM502	12.76 megabytes
TM503	19.14 megabytes
Unformatted Capacity Per Surface	3.19 megabytes
Unformatted Capacity Per Track	10.4 kilobytes

**POWER REQUIREMENTS**

+12 volts D. C.  $\pm 10$  percent, 1.5 amperes typical, 5 amperes maximum during motor start-up, not to exceed 12 seconds, 2 amperes maximum running, with no more than 50 millivolts Periodic and Random Deviation (PARD).

+5 volts D. C.  $\pm 5$  percent, 0.8 amperes typical, 1.2 amperes maximum running, with no more than 50 millivolts PARD.

There are no restrictions in sequencing power supplies on or off.

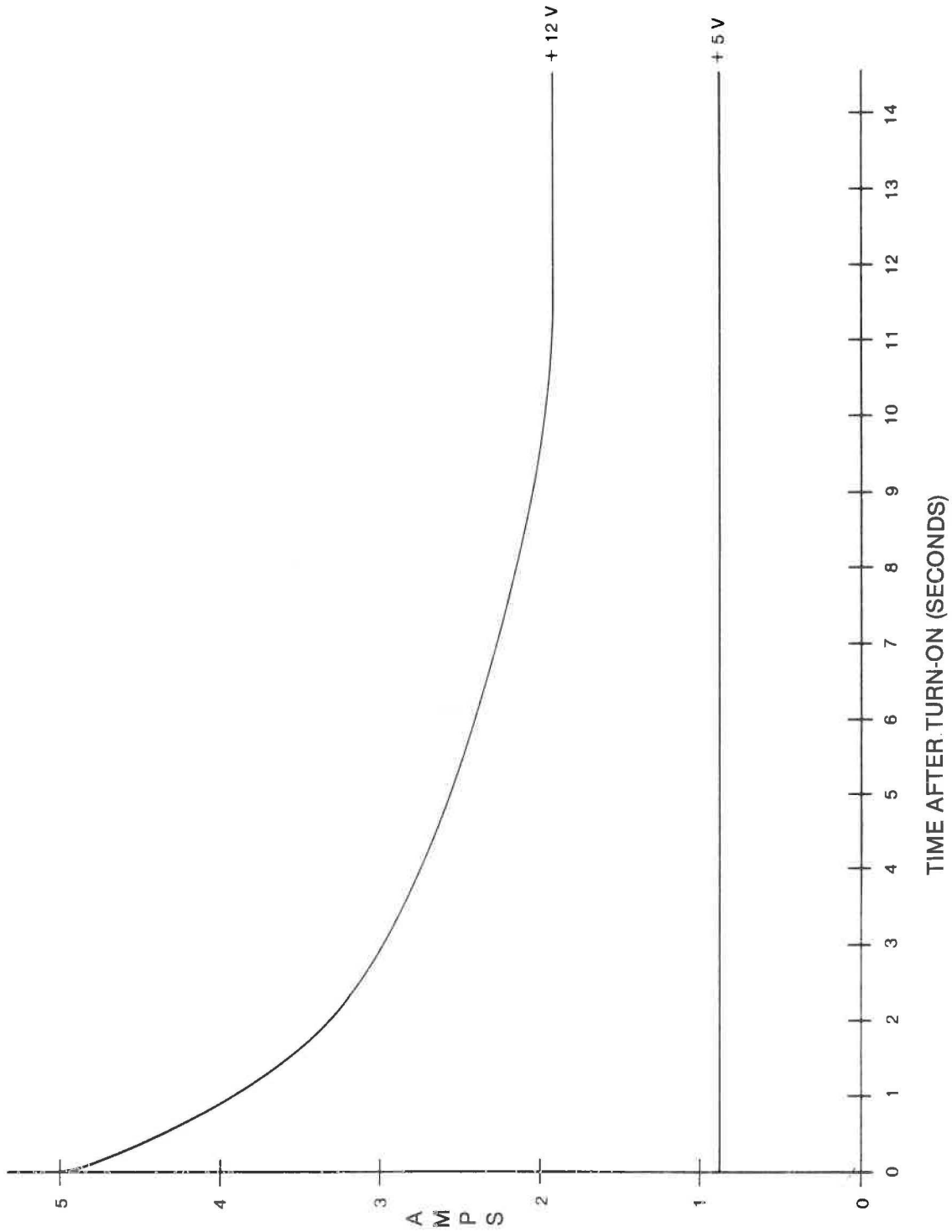

FIGURE 2-2  
TYPICAL STARTING CURRENTS

**TABLE 2-2  
RELIABILITY SPECIFICATIONS**

**SOFT AND HARD READ ERROR RATES, EXCLUSIVE OF MEDIA DEFECTS**

For data that has been verified previously as error free, and when used in conjunction with a data separator and phase lock loop of good design, the recoverable (soft) read error rate for any subsequent read operation shall not exceed one error in  $1 \times 10^{10}$  bits transferred. A recoverable read error is an error that may be corrected within five attempts to reread the data.

The nonrecoverable (hard) read error rates shall not exceed one error in  $1 \times 10^{12}$  bits transferred. A nonrecoverable read error is an error that may not be corrected within five attempts to reread data, providing that the writing of the data previously has been verified as correct. The seek error rate is not to exceed one error in  $1 \times 10^6$  seeks.

**MEDIA DEFECTS**

Any defects on the media surface will be identified on a defect map provided with each drive. This defect map will indicate the head number, track number, and number of bytes from index for each defect. Each defect shall be no longer than 16 bits. Cylinders 000 and 001 are guaranteed error free.

The map is offered as a guide only. The number of defects and their location can change due to customer system variations such as data separators.

Mean Time Between Failures	11,000 power on hours
Mean Time To Repair	30 minutes
Component Design Life	5 years
Preventative Maintenance	Not required



**TABLE 2-3  
ENVIRONMENTAL SPECIFICATIONS**

<p>Ambient Temperature</p> <p>    Operating</p> <p>    Nonoperating</p> <p>Temperature Gradient</p> <p>    Operating</p> <p>    Nonoperating</p> <p>Relative Humidity</p> <p>Relative Humidity Gradient</p> <p>    Operating</p> <p>    Nonoperating</p> <p>Maximum Wet Bulb Temperature</p> <p>Elevation</p> <p>    Operating</p> <p>    Nonoperating</p>	<p>4°C to 50°C, 39°F to 122°F</p> <p>-40°C to 60°C, -40°F to 140°F</p> <p>10°C per hour, 18°F per hour</p> <p>Below that causing condensation</p> <p>8-to-80 percent, noncondensing</p> <p>20 percent per hour</p> <p>Below that causing condensation</p> <p>26°C, 78.8°F, without condensation</p> <p>Density Altitude: -457 to 2,972 meters, -1,500 to 9,750 feet</p> <p>Sea level to 3,650 meters, Sea level to 12,000 feet</p>
--	--

# SECTION 3

## OPERATION

### INTRODUCTION

This section contains information pertinent to the handling, inspection, installation, and operation of the TM500 series of drives.

#### 3.1 UNPACKING THE DRIVE

Each drive is shipped in a protective container which, when bulk packaged, minimizes the possibility of damage during shipment.

Visually examine the shipping container for possible damage. Notify the carrier immediately if any damage is found.

The following procedure is recommended for unpacking the drive.

1. Place the shipping container on a flat work surface.
2. Cut the tape on the shipping container.
3. Remove the foam lid and pads from the shipping container.
4. Remove the inner container.
5. Remove the drive from the inner container.
6. Place the drive on a foam lined surface.

#### CAUTION

*Do not manually rotate the stepper motor or spindle motor. Damage to the heads and disk may result.*

#### NOTE

The inside chamber of the drive is a sealed compartment that must not be opened.

When returning the drive to the service center, be

sure to use prior steps in reverse order, and ensure the foam stiffeners are in the proper location, with the cardboard dividers properly in place between the drives (see Figure 3-1).

#### 3.2 PREINSTALLATION CHECKOUT

Before applying power to the drive, inspect for the following:

1. Ensure the front panel is secure.
2. Ensure the circuit board is secure.
3. Ensure the connectors are firmly seated.
4. Ensure there is no debris or foreign material between the frame and the head/disk casting.
5. Ensure the head/disk housing can move freely on the shock mounts of the frame.
6. Ensure the termination resistor pack and jumper blocks are firmly seated and in the correct configuration.

#### 3.3 MOUNTING THE DRIVE

The drive can be mounted in any vertical or horizontal plane. Eight 6-32 tapped holes are provided for mounting: two on each side and four on the bottom of the frame (see Figure 2-1, page 2-2). The drive is manufactured with some critical internal alignments that must be maintained. Hence, it is important the mounting hardware does not introduce significant stress on the drive.

Any mounting scheme in which the drive is part of the structural integrity of the enclosure is not permitted. Mounting schemes should allow for adjustable brackets or incorporate resilient members to accommodate tolerances.

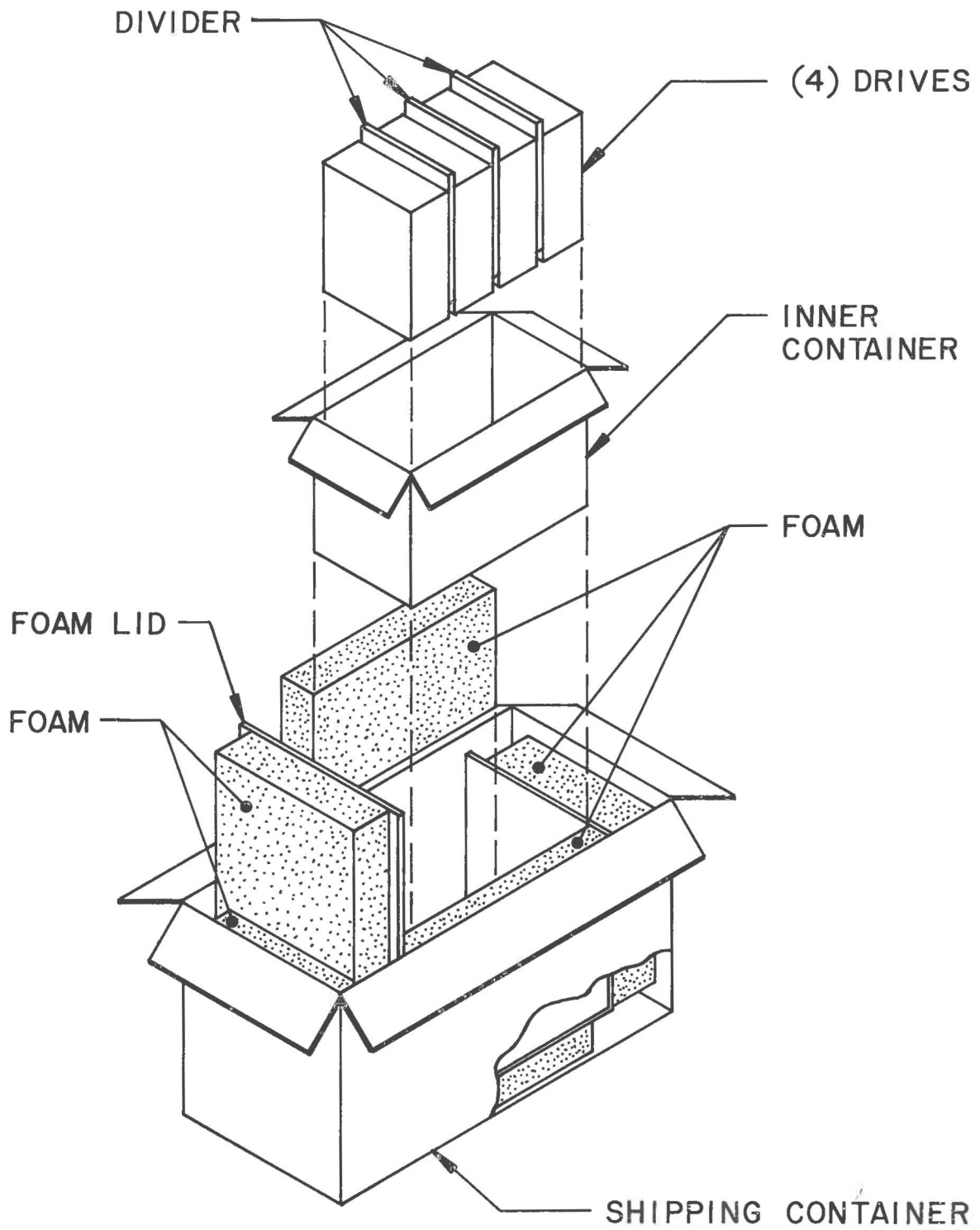

**FIGURE 3-1**  
**FOUR PACK SHIPPING CONTAINER**

## DUST COVER

The design of an enclosure should incorporate a means to prevent contamination from loose items, e.g., dust, lint, and paper chad since the drive does not have a dust cover.

## FREE AIR FLOW

When the drive is mounted so the components have access to the free flow of air, normal convection cooling allows operation over the specified temperature range (see Table 2-3, page 2-7).

## CONFINED ENVIRONMENT

When the drive is mounted in a confined environment, air flow must be provided to maintain specified air temperatures in the vicinity of the motors and the circuit boards.

## 3.4 INTERFACE CONNECTORS

The electrical interface between the drive and the host system is via three connectors. J1 provides control signals for the drive (see Figure 3-2). J2 provides for the radial connection of read/write

data signals (see Figure 3-3). J3 provides for D.C. power (see Figure 3-4).

Table 3-1 contains interface lines. The interface description of the connectors, and the location of each, is contained in this section.

### J1/P1 CONNECTOR

Connection to J1 is through a thirty-four-pin circuit board connector. Figure 3-2 contains the dimensions of this connector. The pins are numbered 1 through 34. The even pins are located on the component side of the circuit board. Pin 2 is located on the end of the circuit board connector closest to the D. C. power connector J3/P3, and is labeled. A key slot is provided between Pins 4 and 6. The recommended mating connector for P1 is 3M ribbon connector P/N 3463-0001, without ears.

### J2/P2 CONNECTOR

Connection to J2 is through a 20-pin circuit board edge connector. Figure 3-3 contains the dimensions of this connector. The pins are numbered 1 through 20. The even pins are located on the component side of the circuit board. The recommended mating connector for P2 is 3M ribbon connector P/N 3461-0001, without ears. A key slot is provided between Pins 4 and 6.

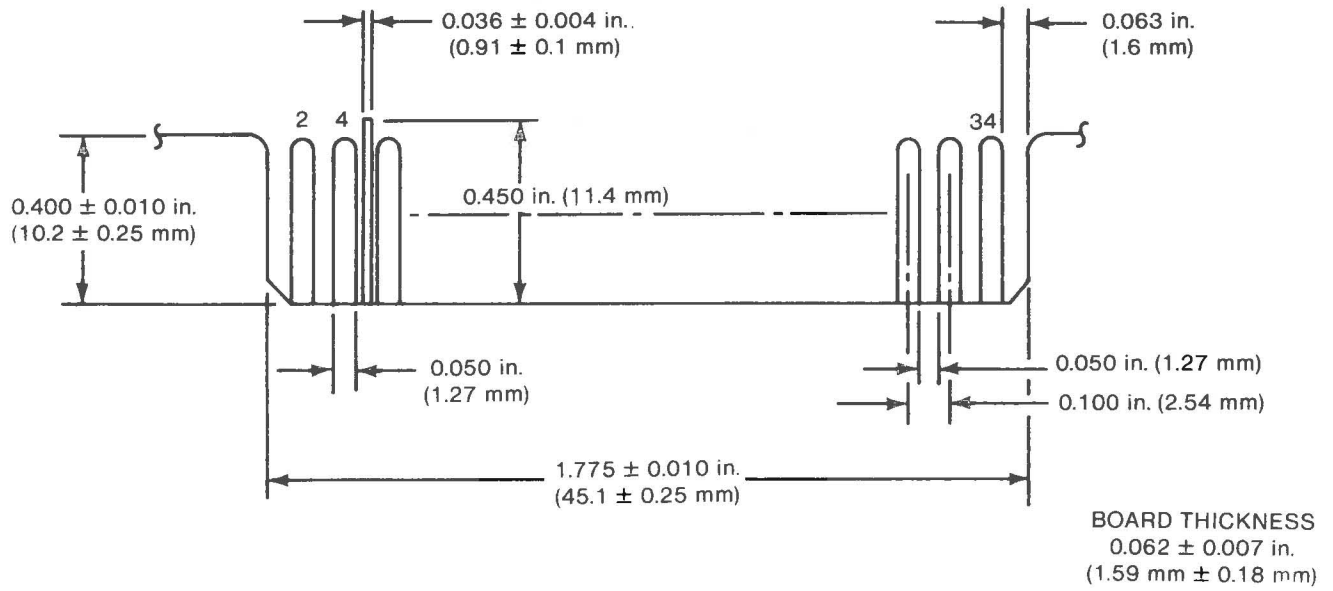

**FIGURE 3-2**  
**J1 EDGE CONNECTOR DIMENSIONS**

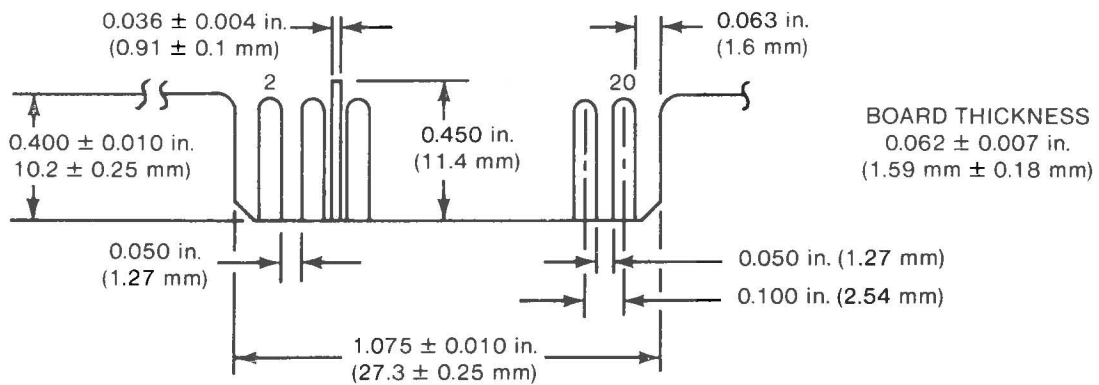

**FIGURE 3-3**  
**J2 EDGE CONNECTOR DIMENSIONS**

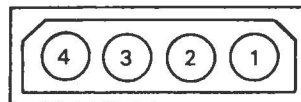

**FIGURE 3-4**  
**J3 POWER CONNECTOR**

**TABLE 3-1  
DRIVE INTERFACE SIGNALS AND PIN ASSIGNMENTS**

Connector	Signal	Interface Pin Number		Signal Type	I/O	Name of Signal
		Ground				
P1 ↑ 34-Pin Ribbon Daisy Chain ↓ P1	2	(1)	S	I	Spare	
	4	(3)	S	I	Head Select 2 <sup>2</sup>	
	6	(5)	S	I	Write Gate	
	8	(7)	S	O	Seek Complete	
	10	(9)	S	O	Track 0	
	12	(11)	S	O	Fault	
	14	(13)	S	I	Head Select 2 <sup>0</sup>	
	16	(15)	—	—	Reserved (To J2 - 7)	
	18	(17)	S	I	Head Select 2 <sup>1</sup>	
	20	(19)	S	O	Index	
	22	(21)	S	O	Ready	
	24	(23)	S	I	Step	
	26	(25)	S	I	Drive Select 0	
	28	(27)	S	I	Drive Select 1	
	30	(29)	S	I	Drive Select 2	
	32	(31)	S	I	Drive Select 3	
34	(33)	S	I	Direction In		
P2 ↑ 20-Pin Ribbon Radial ↓ P2	1	(2)	S	O	Drive Select	
	3	(4)	S	—	Spare	
	5	(6)	—	—	Reserved	
	7	(8)	—	—	Reserved (To J1-16)	
	9	(10)	—	—	Spare	
	11	(12)	—	—	Ground	
	13	—	D	I	+ Write Data	
	14	—	D	I	- Write Data	
	15	(16)	—	—	Ground	
	17	—	D	O	+ Read Data	
18	—	D	O	- Read Data		
19	(20)	—	—	Ground		
P3 ↑ Radial P3	1			—	+ 12 volts D. C. In	
	2			—	+ 12 volts D. C. Return	
	3			—	+ 5 volts D. C. Return	
	4			—	+ 5 volts D. C. In	

**NOTES:**

1. S — Single Ended
2. D — Differential
3. I — Drive Input
4. O — Drive Output

## J3/P3 CONNECTOR

D. C. power connector J3 is a four-pin AMP Mate-N-Lok connector, P/N 350211-1, mounted on the solder side of the circuit board. The recommended mating connector, P3, is AMP P/N 1-480424-0, utilizing AMP pins P/N 60619-4. J3 pins are labeled on the J3 connector (see Figure 3-4). J3 cabling must be 18 AWG, minimum.

## FRAME GROUND CONNECTOR

The frame ground connector is Faston AMP P/N 61761-2. The recommended mating connector is AMP P/N 62187-1. To realize error rates (see Table 2-2), it must be connected directly to the centrally located system ground via an 18 AWG, minimum, cable.

### 3.5 INTERFACE LINE DESCRIPTIONS

The interface for the TM500 series drive is available in one configuration. It is compatible with industry standard drives. Compatibility is defined as using the same pin assignment where the signal and function are common. Table 3-1 contains pin assignments.

The interface may be connected in the radial or daisy chain configuration (see Figures 3-5 and 3-6).

## INPUT CONTROL SIGNALS

The input control signals are of two kinds: those to be multiplexed in a multiple drive system and those that do the multiplexing. The input control signals to be multiplexed are: Reduced Write Current, Write Gate, Head Select Line 2<sup>0</sup>, Head Select Line 2<sup>1</sup>, Head Select Line 2<sup>2</sup>, Step, and Direction In. The multiplexing signal is Drive Select 0, Drive Select 1, Drive Select 2 or Drive Select 3.

The input signals have the following electrical specifications, as measured at the drive. Figure 3-7 illustrates the recommended circuit.

True: 0.0 volt D. C. to 0.4 volt D. C. at  $I = -40$  milliamperes, maximum

False: 2.5 volts D. C. to 5.25 volts D. C. at  $I = 250$  microamperes, maximum (open) <sup>L</sup>

All input signals share a 220/330 ohm resistor pack for line termination. Only the last drive in the chain should have the resistor pack installed.

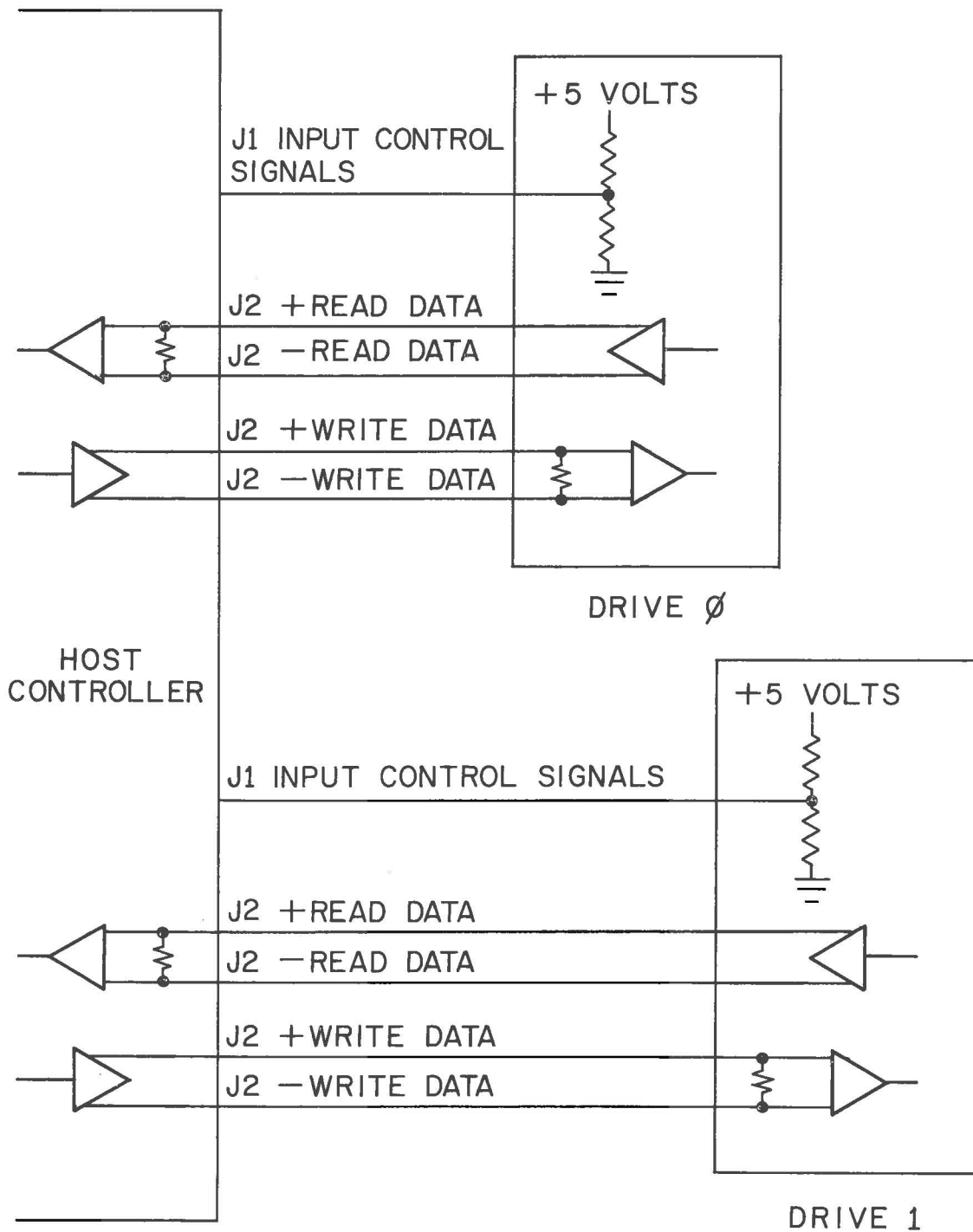
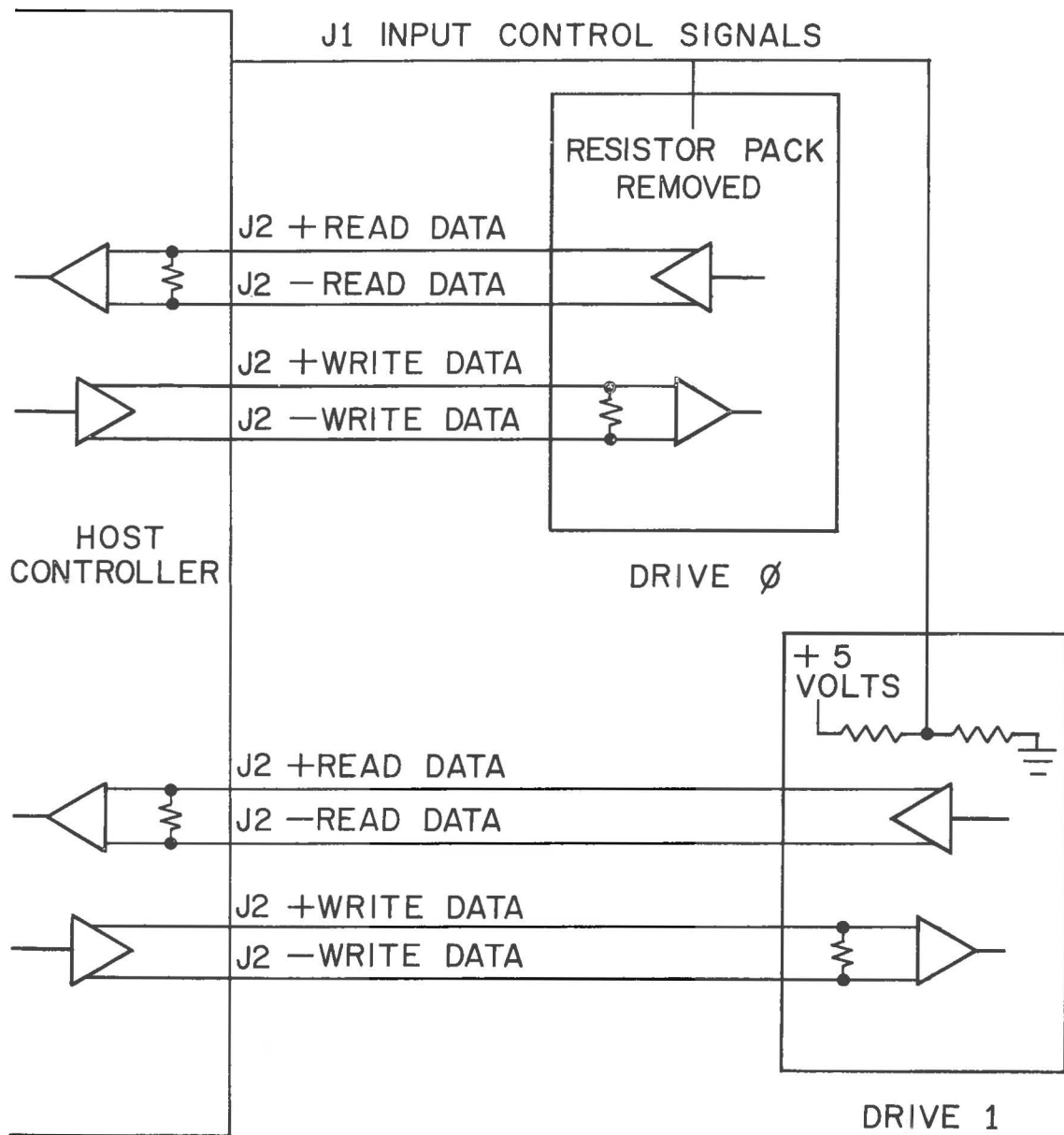
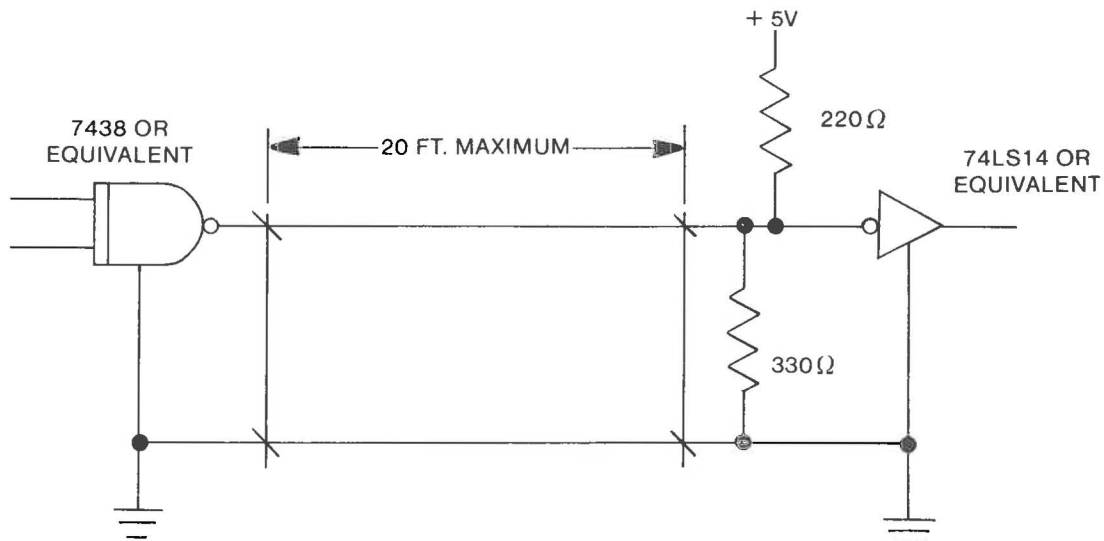

FIGURE 3-5  
RADIAL CONFIGURATION





**FIGURE 3-6**  
**DAISY CHAIN CONTROL LINES**



**FIGURE 3-7**  
**CONTROL SIGNAL/DRIVER RECEIVER CIRCUIT COMBINATION**

### WRITE GATE

The active state of this signal or logical zero level enables write data to be written on the disk. The inactive state of this signal enables the data to be transferred from the drive. In addition, the inactive state enables the step pulse to step the read/write actuator.

### HEAD SELECT LINES $2^0, 2^1, 2^2$

These three lines provide for the selection of each read/write head in a binary coded sequence. Head Select Line  $2^0$  is the least significant line. The heads are numbered 0 through 5. When all Head Select Lines are false, Head 0 is selected. Table 3-2 describes which head is selected for the head select lines.

**TABLE 3-2  
HEAD SELECT LINES**

Head Select Line			Head Selected	
$2^2$	$2^1$	$2^0$	Jumper 3 PW13 OUT TM501, TM502	Jumper 3 PW13 IN TM503
1	1	1	0	0
1	1	0	1	1
1	0	1	2	2
1	0	0	3	3
0	1	1	0	4
0	1	0	1	5
0	0	1	2	0
0	0	0	3	1

Head recovery time (head-to-head select, write-to-read recovery, or read-to-write recovery) is 2.4 microseconds maximum.

**STEP**

This interface line is a control signal that causes the read/write heads to move with the direction of motion defined by the Direction In line.

The access motion is initiated at the logical true-

to-logical false transition or the trailing edge of this signal pulse. Any change in the Direction In line must be made at least 100 nanoseconds before the true-to-false edge of the step pulse. The quiescent state of this line should be held logically false.

The read/write head moves at the rate of the incoming step pulses. The minimum time between successive steps is three milliseconds, except during execution of a buffered seek. The minimum pulse width is one microsecond. Figure 3-8 illustrates the step timing.

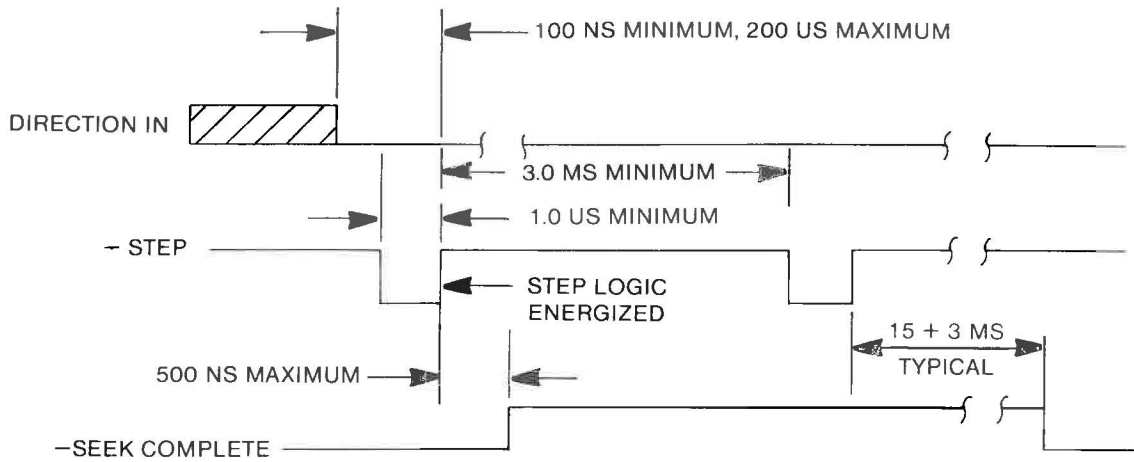

**FIGURE 3-8  
STEP MODE TIMING**

**BUFFERED SEEK**

The buffered seek uses an onboard microprocessor that calculates the most efficient seek algorithm for the user. The user need only issue step pulses in accordance with the timing shown (see Figure 3-9). Step pulses are issued in a 1:1 ratio to the cylinders moved. If more pulses are issued than there are cylinders left to move, the heads soft stop at the last cylinder.

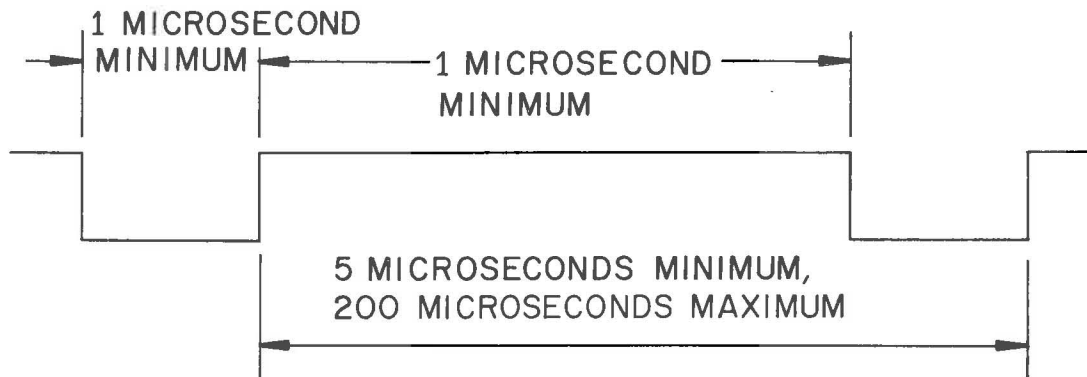

**FIGURE 3-9  
BUFFERED SEEK STEP PULSES**

## DIRECTION IN

This signal defines the direction of motion of the read/write head when the Step line is pulsed. An open circuit or logical false defines the direction as "out". If a pulse is applied to the Step line, the read/write heads move away from the center of the disk. If this line is true, the direction is defined as "in", and the read/write heads move in toward the center of the disk.

Seek Complete must be true prior to changing directions and the application of additional step pulses.

## REDUCED WRITE CURRENT

The Reduced Write Current input line is terminated, but is not used in the TM500 series drives. The microprocessor automatically switches write current.

## DRIVE SELECT 0 THROUGH DRIVE SELECT 3

These control signals enable the selected drive's input receivers and output drivers. When logically false, the output drivers are open circuits and the input receivers do not acknowledge signals presented to them.

Selecting the appropriate jumper block at W9 through W12 determines which select line activates the drive.

### NOTE

Only one drive may be selected at a time.

## OUTPUT CONTROL SIGNALS

The output control signals are driven with an open collector output stage capable of sinking a maximum of 40 milliamperes in a true state, with a maximum voltage of 0.4 volt measured at the driver. When the line driver is in the false state, the driver transistor is off, and the collector cutoff is a maximum of 250 microamperes.

All J1 output lines are enabled by the respective Drive Select lines.

## SEEK COMPLETE

The Seek Complete signal goes true when the read/write heads have settled on the final track at the end of a seek. Reading or writing should not be attempted when Seek Complete is false.

Seek complete goes false:

1. When a recalibration sequence is initiated by the microprocessor at power on because the read/write heads are not over Track 0.
2. 500 nanoseconds, maximum, after the trailing edge of a step pulse or a series of step pulses.
3. When power is momentarily lost, Seek Complete is false when power is restored and remains false until an automatic recalibration is completed.

## TRACK 0

The Track 0 signal indicates a true state only when the drive's read/write heads are positioned at Track 0, the outermost data track.

## FAULT

The Fault signal is used to indicate a condition exists in the drive that could cause improper writing on the disk. When this line is true, further writing is inhibited, as are other drive functions, until the condition is corrected.

This condition is caused by either the +12 volt or +5 volt supply dropping below the specified limits, and on power up until a successful recalibration sequence is completed.

## INDEX

The Index signal is provided once each revolution, 16.7 milliseconds nominal, to indicate the beginning of the track. Normally, this signal is false and makes the transition to true to indicate Index. Only the transition from logical false to logical true is valid.

## READY

When true, the Ready signal, together with Seek Complete, indicates that the drive is ready to read, write or seek, and the I/O signals are valid. When this line is false, all controller-initiated functions are inhibited.

The typical time after power on for Ready to be true is fifteen seconds. Track 0, Seek Complete, and Ready come true sequentially during power on.

## SELECT STATUS

A Status line is provided at the J2/P2 connector to inform the host system of the selection status of the drive.

The Drive Selected line is driven by a TTL open collector drive (see Figure 3-7). This signal goes active only when the drive is programmed as Drive X, X = 0, 1, 2, or 3, by programming the shunt on the drive, and the Drive Select X line at J1/P1 is activated by the host system.

## DATA TRANSFER SIGNALS

All lines associated with the transfer of data between the drive and the host system are differential in nature and may be multiplexed. These lines are provided at the J2/P2 connector on all drives. Signal levels are defined by RS-422A.

Two pairs of balanced lines are used for the transfer of data: MFM Write Data and MFM Read Data. Figure 3-10 illustrates the driver/receiver combination used with the drive for data transfer signals.

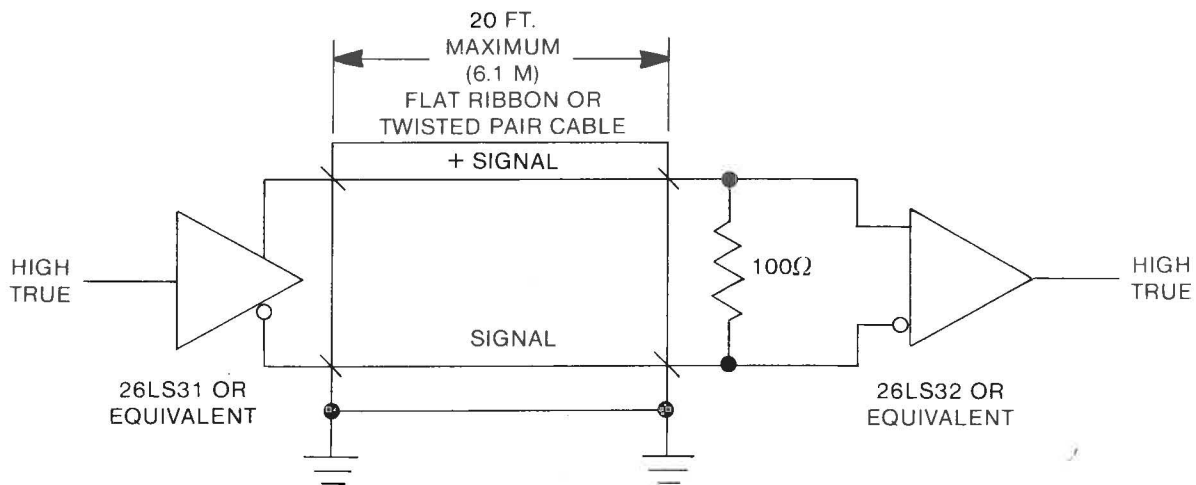

**FIGURE 3-10**  
**DATA TRANSFER LINE DRIVER RECEIVER**

## **MFM WRITE DATA**

This is a differential pair of lines that define the flux transition to be written on the track. The transition of the +MFM Write Data line going more positive than the —MFM Write Data line causes a flux reversal on the track if Write Gate is active. This signal must be driven to an inactive state, +MFM Write Data more negative than —MFM Write Data, by the host system when in a read mode.

The delay from the leading edge of Write Gate to the Write Data pulse is 400 nanoseconds, maximum.

## **MFM READ DATA**

The data recovered by reading a prerecorded track is transmitted to the host system via the differential pair of MFM Read Data lines. The transition of the +MFM Read Data line going more positive than the -MFM Read Data line represents a flux reversal on the track of the selected head.

### **3.6 DRIVE ADDRESS AND OPTION SELECTION**

The drive address and option selection is determined by the programmable jumper blocks located on the logic circuit board. If jumper configurations are changed, power should be cycled off and on, so that the microprocessor can recognize the new configuration.

The option programming guide is contained in Table 3-3

### **3.7 SHIPPING PACK AND HANDLING**

Figures 3-11 through 3-13 provide basic information on recommended design guidelines for packaging systems.

From various drop tests conducted, it has been established that drives subjected to shock loads in excess of twenty G's may be damaged and consequently not meet published performance specifications for data reliability, margins, and function.

In order to avoid media or head damage, it is recommended that:

1. Drive mounting designs incorporate some type of shock dampening consideration.
2. Shipping cartons protect the drive within the system to withstand twenty G's.
3. Individual drives are handled carefully, e.g., receiving and in-process personnel are properly trained, surface mats are used on working surfaces to prevent the possibility of "handling shock," and padding is placed on racks and carts.

Please emphasize the critical aspects of handling these drives to all concerned people. In addition, Tandon provides technical assistance on packing and handling to customers upon request.

**TABLE 3-3  
OPTION PROGRAMMING GUIDE**

<b>W1 - W3 Jumper</b>	<b>Function</b>	<b>Factory Programmed</b>	<b>Usage</b>
W1	Track Fault	O	Install for excess track fault.
W2	Test	O	Install for factory test.
W3	Disable Limit	O	Install to disable soft limits.
W4	Spin Select	O	Install for spin select.
W5	Tracks	S	Install for standard version only.
W6	Motor Type	—	Install for Type 1.8 <sup>0</sup> motor.
RTW7	Read Terminator	I	Close only at end drive of daisy chain data. Closed for radial data.
WTW8	Write Terminator	I	
S4W9	Drive Select 4	O	Install one of four plugs only. Plug corresponds to drive address.
S3W10	Drive Select 3	O	
S2W11	Drive Select 2	O	
S1W12	Drive Select 1	I	
3PW13	Three Disk	503	Close for Model TM503 only.
U22	Terminator Pack	I	Install in end drive of daisy chain.

**NOTES:**

- O = Omit
- I = Install
- S = Close jumper for standard version only.
- 503 = Close jumper for TM503 only.



STEP A.

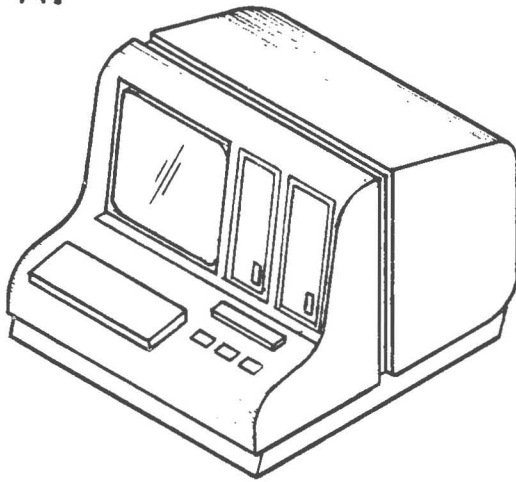

ENCLOSE UNIT IN POLY BAG  
TO AVOID SURFACE  
SCRATCHES AND  
OTHER DAMAGE

STEP B.

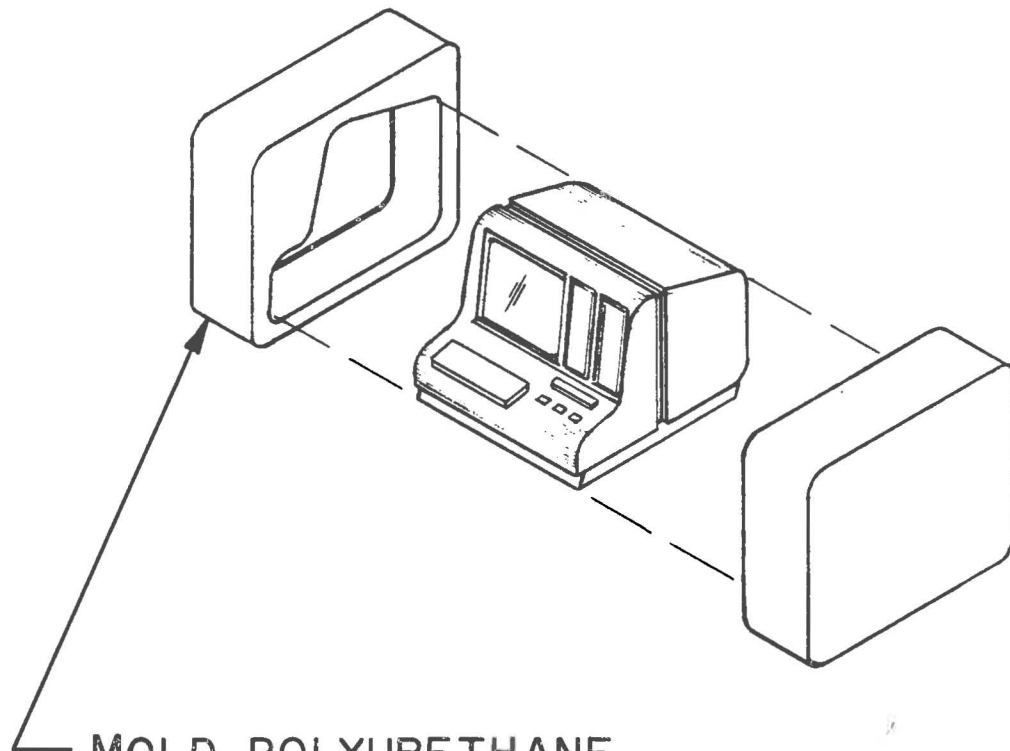

MOLD POLYURETHANE  
"CLAMSHELL" TO "CUBE" UNIT

FIGURE 3-11  
RECOMMENDED SHIPPING PACK DESIGN,  
CONFIGURATION 1

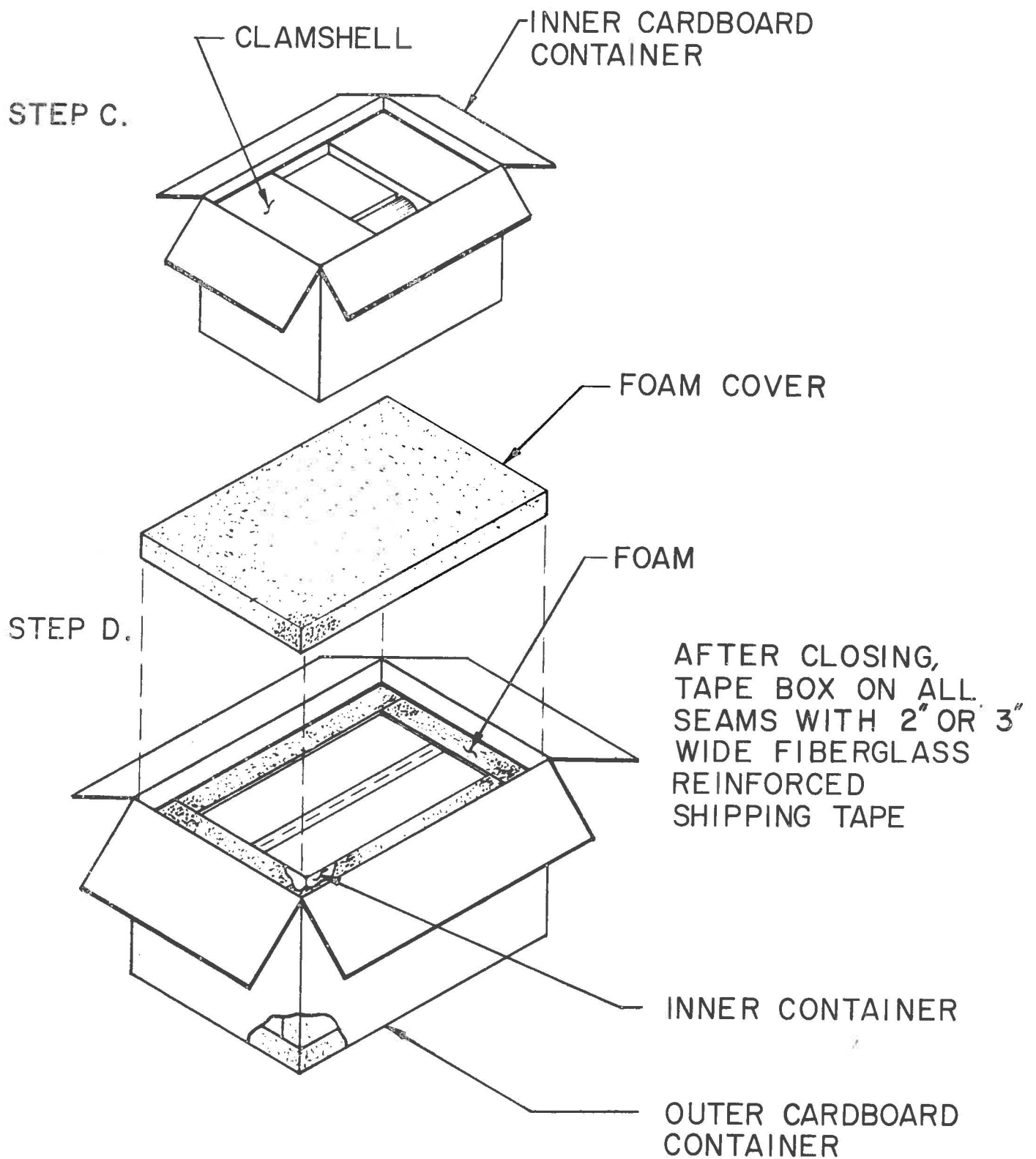
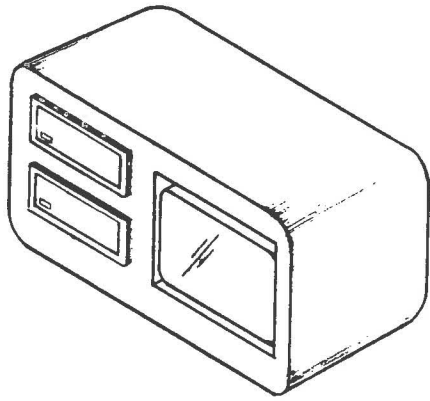

FIGURE 3-11 (CONTINUED)  
RECOMMENDED SHIPPING PACK DESIGN,  
CONFIGURATION 1

STEP A.



ENCLOSE UNIT IN POLY BAG  
TO AVOID SURFACE  
SCRATCHES AND  
OTHER DAMAGE

STEP B.

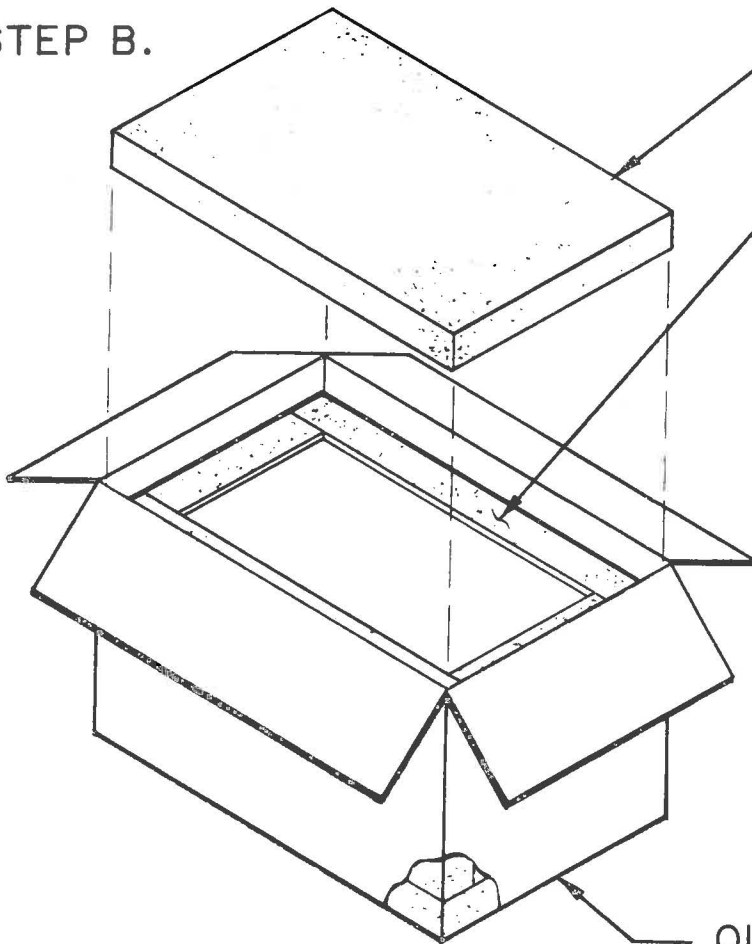

FOAM COVER

FOAM

AFTER CLOSING,  
TAPE BOX ON ALL  
SEAMS WITH 2" OR 3"  
WIDE FIBERGLASS  
REINFORCED  
SHIPPING TAPE

OUTER CARDBOARD  
CONTAINER

FIGURE 3-12  
RECOMMENDED SHIPPING PACK DESIGN,  
CONFIGURATION 2

STEP A.

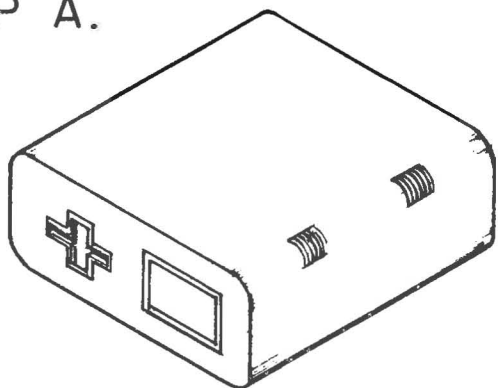

ENCLOSE UNIT IN POLY BAG  
TO AVOID SURFACE  
SCRATCHES AND  
OTHER DAMAGE

STEP B.

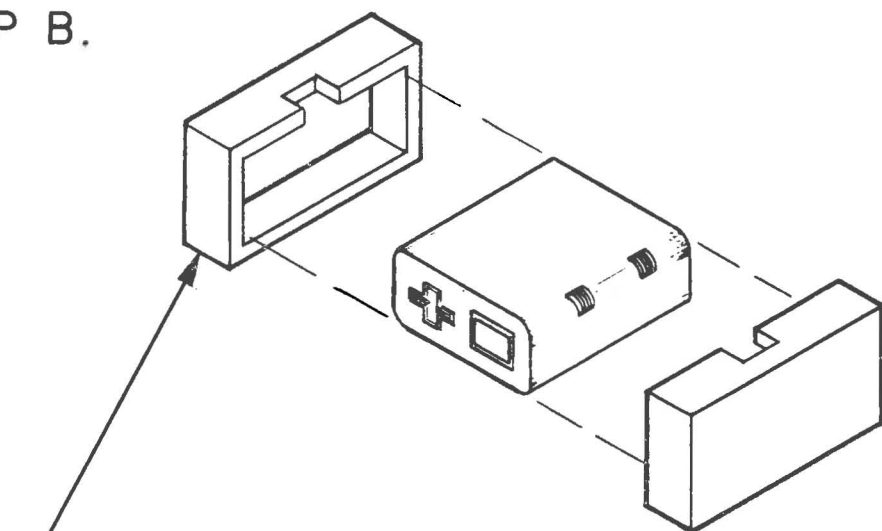

MOLDED POLYURETHANE  
"CLAMSHELL" TO "CUBE" UNIT

FIGURE 3-13  
RECOMMENDED SHIPPING PACK DESIGN,  
CONFIGURATION 3

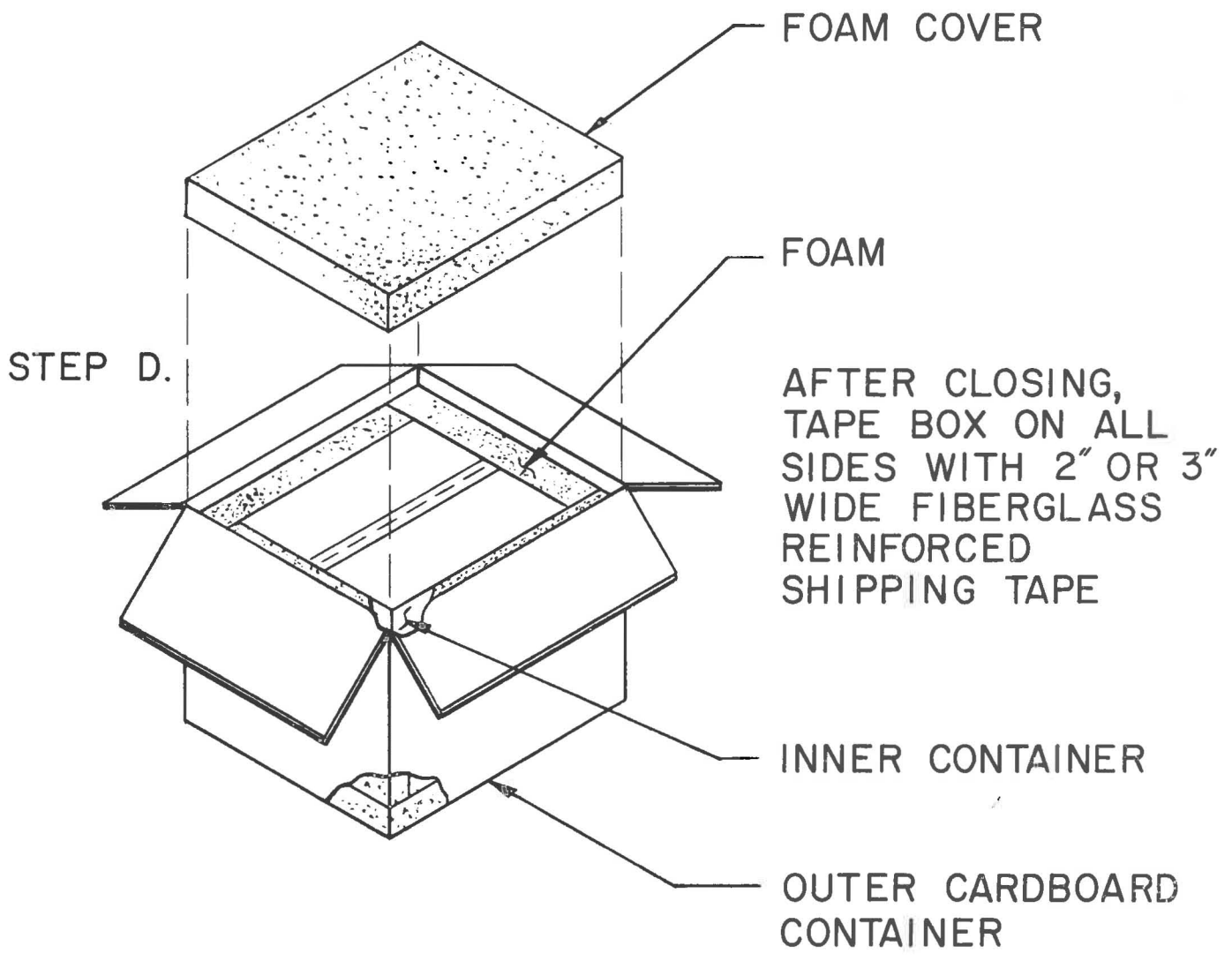
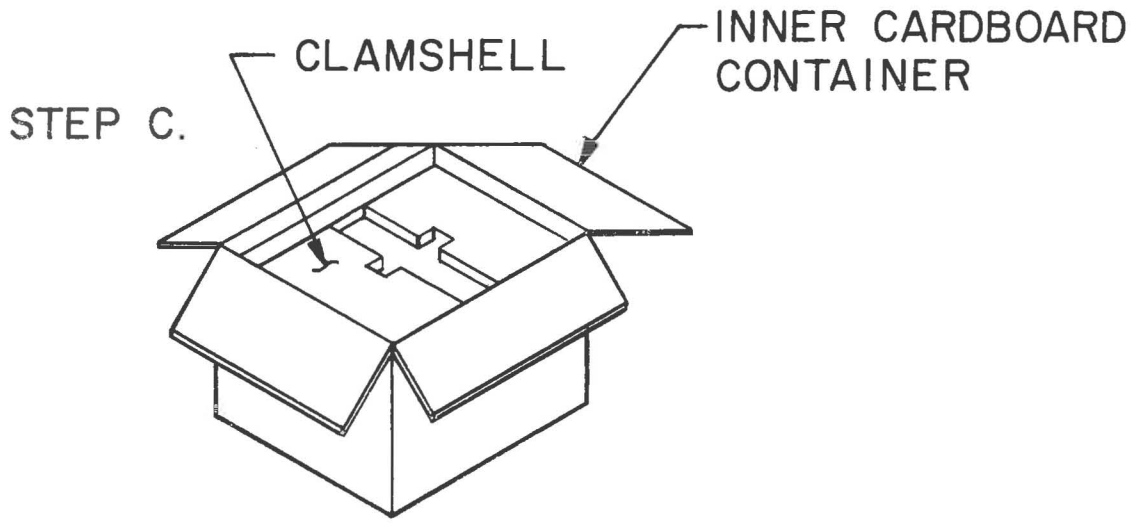

**FIGURE 3-13 (CONTINUED)**  
**RECOMMENDED SHIPPING PACK DESIGN**  
**CONFIGURATION 3**

POLYETHER POLYESTER FOAM \*

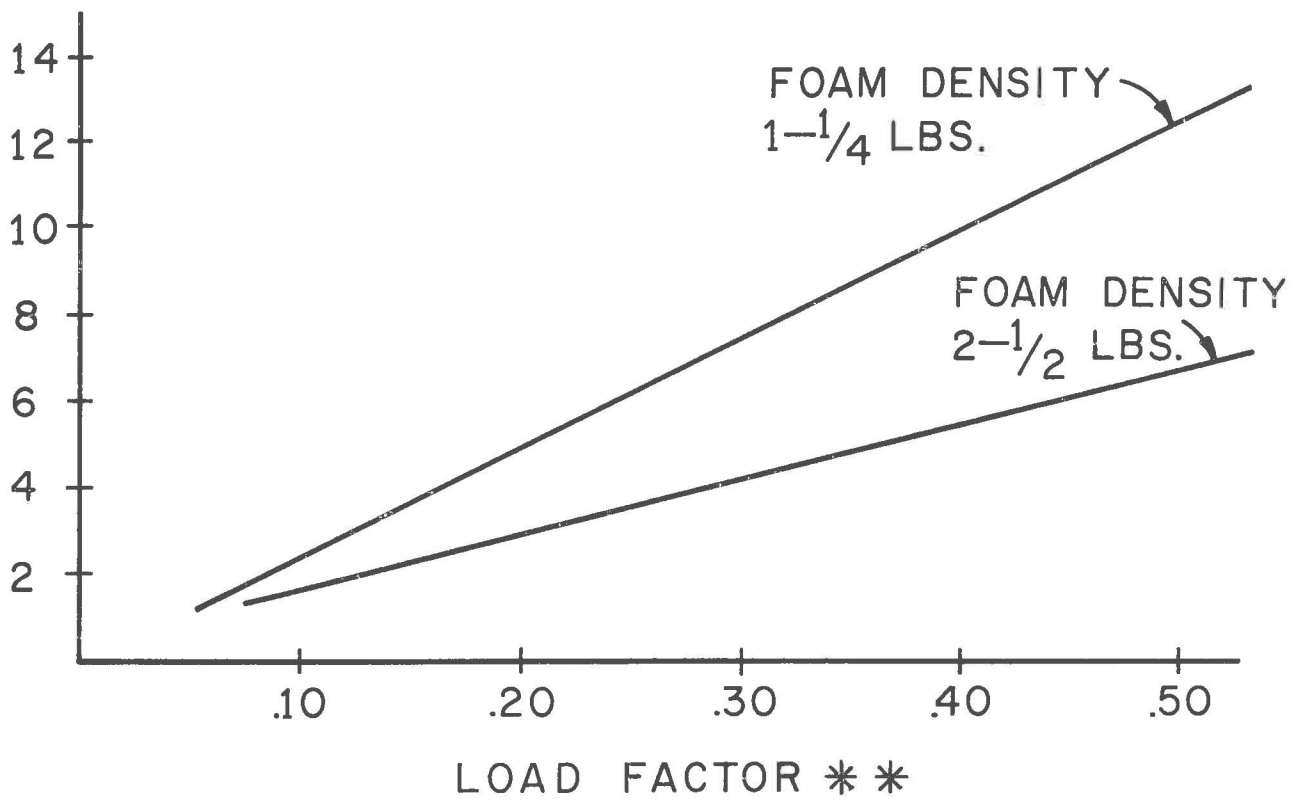

NOTE

THE GRAPH GIVES FOAM THICKNESSES TO SATISFY 10 G MINIMUM SHOCK LOADS ON STANDARD 30 INCH DROP TEST. HENCE, ALL PACKAGE DESIGNS SHOULD BE TESTED TO VERIFY THEIR ULTIMATE PERFORMANCE.

\* THICKNESS IS IN INCHES.

\*\* THE LOAD FACTOR IS IN LBS. PER SQ. INCH.

THE FORMULA IS :  $LOAD\ FACTOR = \frac{UNIT'S\ WEIGHT\ (LBS.)}{SMALLEST\ SIDE\ OF\ UNIT\ (SQ.\ INCHES)}$

FIGURE 3-14  
LOAD GRAPH

**Tandon**

CORPORATE OFFICES  
20320 PRAIRIE STREET  
CHATSWORTH, CA 91311

TEL. NO.: (213) 993-6644

TELEX NO.: 194794

TWX NO.: 910-494-1721