

TANDY®

300-Bps Intelligent Modem DCM-7

OPERATION MANUAL

Cat. No. 26-1394



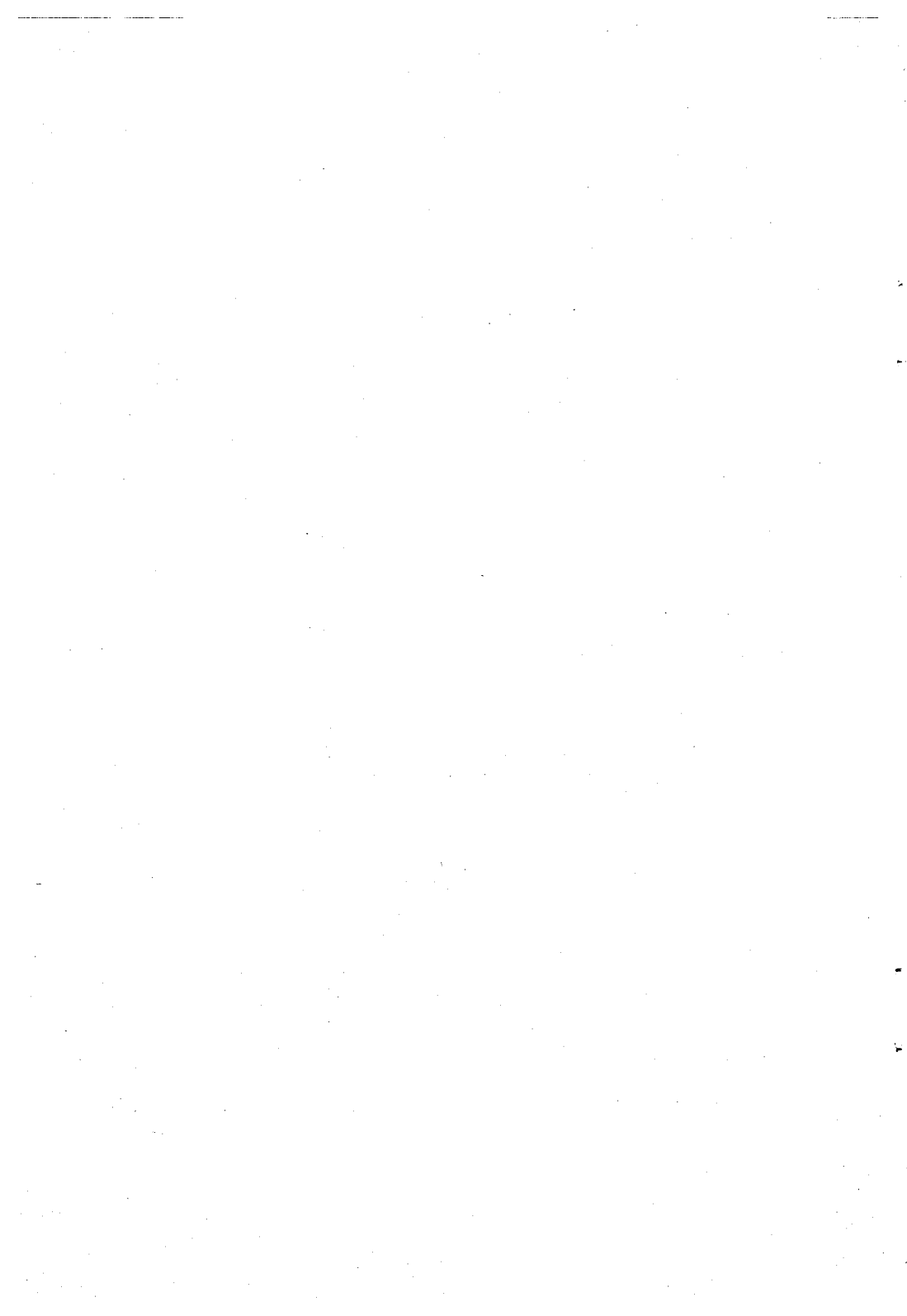

TERMS AND CONDITIONS OF SALE AND LICENSE OF TANDY COMPUTER EQUIPMENT AND SOFTWARE PURCHASED FROM RADIO SHACK COMPANY-OWNED COMPUTER CENTERS, RETAIL STORES AND RADIO SHACK FRANCHISEES OR DEALERS AT THEIR AUTHORIZED LOCATIONS

LIMITED WARRANTY

I. CUSTOMER OBLIGATIONS

- A. CUSTOMER assumes full responsibility that this computer hardware purchased (the "Equipment"), and any copies of software included with the Equipment or licensed separately (the "Software") meets the specifications, capacity, capabilities, versatility, and other requirements of CUSTOMER.
- B. CUSTOMER assumes full responsibility for the condition and effectiveness of the operating environment in which the Equipment and Software are to function, and for its installation.

II. LIMITED WARRANTIES AND CONDITIONS OF SALE

- A. For a period of ninety (90) calendar days from the date of the Radio Shack sales document received upon purchase of the Equipment, RADIO SHACK warrants to the original CUSTOMER that the Equipment and the medium upon which the Software is stored is free from manufacturing defects. **This warranty is only applicable to purchases of Tandy Equipment by the original customer from Radio Shack company-owned computer centers, retail stores, and Radio Shack franchisees and dealers at their authorized locations.** The warranty is void if the Equipment's case or cabinet has been opened, or if the Equipment or Software has been subjected to improper or abnormal use. If a manufacturing defect is discovered during the stated warranty period, the defective Equipment must be returned to a Radio Shack Computer Center, a Radio Shack retail store, a participating Radio Shack franchisee or a participating Radio Shack dealer for repair, along with a copy of the sales document or lease agreement. The original CUSTOMER'S sole and exclusive remedy in the event of a defect is limited to the correction of the defect by repair, replacement, or refund of the purchase price, at RADIO SHACK'S election and sole expense. RADIO SHACK has no obligation to replace or repair expendable items.
- B. RADIO SHACK makes no warranty as to the design, capability, capacity, or suitability for use of the Software, except as provided in this paragraph. Software is licensed on an "AS IS" basis, without warranty. The original CUSTOMER'S exclusive remedy, in the event of a Software manufacturing defect, is its repair or replacement within thirty (30) calendar days of the date of the Radio Shack sales document received upon license of the Software. The defective Software shall be returned to a Radio Shack Computer Center, a Radio Shack retail store, a participating Radio Shack franchisee or Radio Shack dealer along with the sales document.
- C. Except as provided herein no employee, agent, franchisee, dealer or other person is authorized to give any warranties of any nature on behalf of RADIO SHACK.
- D. **EXCEPT AS PROVIDED HEREIN, RADIO SHACK MAKES NO EXPRESS WARRANTIES, AND ANY IMPLIED WARRANTY OF MERCHANTABILITY OR FITNESS FOR A PARTICULAR PURPOSE IS LIMITED IN ITS DURATION TO THE DURATION OF THE WRITTEN LIMITED WARRANTIES SET FORTH HEREIN.**
- E. Some states do not allow limitations on how long an implied warranty lasts, so the above limitation(s) may not apply to CUSTOMER.

III. LIMITATION OF LIABILITY

- A. **EXCEPT AS PROVIDED HEREIN, RADIO SHACK SHALL HAVE NO LIABILITY OR RESPONSIBILITY TO CUSTOMER OR ANY OTHER PERSON OR ENTITY WITH RESPECT TO ANY LIABILITY, LOSS OR DAMAGE CAUSED OR ALLEGED TO BE CAUSED DIRECTLY OR INDIRECTLY BY "EQUIPMENT" OR "SOFTWARE" SOLD, LEASED, LICENSED OR FURNISHED BY RADIO SHACK, INCLUDING, BUT NOT LIMITED TO, ANY INTERRUPTION OF SERVICE, LOSS OF BUSINESS OR ANTICIPATORY PROFITS OR CONSEQUENTIAL DAMAGES RESULTING FROM THE USE OR OPERATION OF THE "EQUIPMENT" OR "SOFTWARE." IN NO EVENT SHALL RADIO SHACK BE LIABLE FOR LOSS OF PROFITS, OR ANY INDIRECT, SPECIAL, OR CONSEQUENTIAL DAMAGES ARISING OUT OF ANY BREACH OF THIS WARRANTY OR IN ANY MANNER ARISING OUT OF OR CONNECTED WITH THE SALE, LEASE, LICENSE, USE OR ANTICIPATED USE OF THE "EQUIPMENT" OR "SOFTWARE." NOTWITHSTANDING THE ABOVE LIMITATIONS AND WARRANTIES, RADIO SHACK'S LIABILITY HEREUNDER FOR DAMAGES INCURRED BY CUSTOMER OR OTHERS SHALL NOT EXCEED THE AMOUNT PAID BY CUSTOMER FOR THE PARTICULAR "EQUIPMENT" OR "SOFTWARE" INVOLVED.**
- B. RADIO SHACK shall not be liable for any damages caused by delay in delivering or furnishing Equipment and/or Software.
- C. No action arising out of any claimed breach of this Warranty or transactions under this Warranty may be brought more than two (2) years after the cause of action has accrued or more than four (4) years after the date of the Radio Shack sales document for the Equipment or Software, whichever first occurs.
- D. Some states do not allow the limitation or exclusion of incidental or consequential damages, so the above limitation(s) or exclusion(s) may not apply to CUSTOMER.

IV. SOFTWARE LICENSE

RADIO SHACK grants to CUSTOMER a non-exclusive, paid-up license to use the TANDY Software on one computer, subject to the following provisions:

- A. Except as otherwise provided in this Software License, applicable copyright laws shall apply to the Software.
- B. Title to the medium on which the Software is recorded (cassette and/or diskette) or stored (ROM) is transferred to CUSTOMER, but not title to the Software.
- C. CUSTOMER may use Software on a multiuser or network system only if either, the Software is expressly labeled to be for use on a multiuser or network system, or one copy of this software is purchased for each node or terminal on which Software is to be used simultaneously.
- D. CUSTOMER shall not use, make, manufacture, or reproduce copies of Software except for use on one computer and as is specifically provided in this Software License. Customer is expressly prohibited from disassembling the Software.
- E. CUSTOMER is permitted to make additional copies of the Software **only** for backup or archival purposes or if additional copies are required in the operation of one computer with the Software, but only to the extent the Software allows a backup copy to be made. However, for TRSDOS Software, CUSTOMER is permitted to make a limited number of additional copies for CUSTOMER'S own use.
- F. CUSTOMER may resell or distribute unmodified copies of the Software provided CUSTOMER has purchased one copy of the Software for each one sold or distributed. The provisions of this Software License shall also be applicable to third parties receiving copies of the Software from CUSTOMER.
- G. All copyright notices shall be retained on all copies of the Software.

V. APPLICABILITY OF WARRANTY

- A. The terms and conditions of this Warranty are applicable as between RADIO SHACK and CUSTOMER to either a sale of the Equipment and/or Software License to CUSTOMER or to a transaction whereby Radio Shack sells or conveys such Equipment to a third party for lease to CUSTOMER.
- B. The limitations of liability and Warranty provisions herein shall inure to the benefit of RADIO SHACK, the author, owner and/or licensor of the Software and any manufacturer of the Equipment sold by Radio Shack.

VI. STATE LAW RIGHTS

The warranties granted herein give the **original** CUSTOMER specific legal rights, and the **original** CUSTOMER may have other rights which vary from state to state.

The FCC Wants You to Know

This equipment generates and uses radio frequency energy. If not installed and used properly, that is in strict accordance with the manufacturer's instructions, it may cause interference to radio and television reception.

It has been type tested and found to comply with the limits for a Class B computing device in accordance with the specifications in Subpart J of Part 15 of FCC Rules, which are designed to provide reasonable protection against such interference in a residential installation. However, there is no guarantee that interference will not occur in a particular installation.

If this equipment does cause interference to radio or television reception, which can be determined by turning the equipment off and on, the user is encouraged to try to correct the interference by one or more of the following measures:

- Reorient the receiving antenna
- Relocate the computer with respect to the receiver
- Move the computer away from the receiver
- Plug the computer into a different outlet so that computer and receiver are on different branch circuits.

Warning

This equipment has been certified to comply with the limits for a Class B computing device, pursuant to Subpart J of Part 15 of FCC Rules. Only peripherals (computer input/output devices, terminals, printers, etc.) certified to comply with the Class B limits may be attached to this computer. Operation with non-certified peripherals is likely to result in interference to radio and TV reception.

2/86

300-Bps Intelligent Modem DCM-7 Operation Manual:
© 1986 Tandy Corporation, Fort Worth, Texas 76102 U.S.A.
All Rights Reserved.

Reproduction or use, without express written permission from Tandy Corporation, of any portion of this manual is prohibited. While reasonable efforts have been taken in the preparation of this manual to assure its accuracy, Tandy Corporation assumes no liability resulting from any errors or omissions in this manual, or from the use of the information contained herein.

Hayes® is a registered trademark of Hayes Microcomputer Products, Inc.

XENIX® is a registered trademark of Microsoft Corporation.

10 9 8 7 6 5 4 3 2 1

Contents

Introduction	1
1 Description of the DCM-7	3
Protocol (DIP) switches	5
Communications protocol	8
2 Tandy protocol mode operation	11
Manual v. automatic operation	11
Originate v. answer mode	11
Sample programming sessions	11
Manual mode operations	14
Automatic mode operations	15
Analog self-test mode	17
Always auto-answer mode operation	18
On-line abort conditions	18
Result codes	19
3 Hayes® protocol mode operation	21
Command codes	21
Registers	24
Result codes	26
Logons in MS-DOS operating systems	26
Appendices	
A Tandy protocol reference	31
B Hayes protocol reference	39
Programming commands	39
Registers	44
Data line monitoring	48
C Connecting the DCM-7	49
Telephone connections	49
Computer connections	51
Power source	51

D XENIX® operations	53
E Troubleshooting	55
Analog loop self-test	55
Multi-line phone operation	56
F Specifications	57
Performance	57
Physical/environmental	57
G Schematic diagram	59
Index	61

Tables

1	DIP Switch Settings in Tandy Protocol Mode	6
2	DIP Switch Settings in Hayes Protocol Mode	8
3	Result Codes (Tandy)	19
4	Commands with Parameters (Hayes)	22
5	Basic Command Codes (Hayes)	23
6	Dialing and Answering Command Codes (Hayes)	23
7	Registers (Hayes)	24
8	Result Codes (Hayes)	26
9	Programming Commands (Tandy)	31
10	List Settings and Related Commands (Tandy)	36
11	Dialer Codes (Hayes)	40
12	Modem-to-Computer Cables	51
13	Computer Option Boards	51

Introduction

With the Tandy direct-connect, 300-Bps Intelligent Modem DCM-7, your computer or data terminal can communicate with other computers or terminals using ordinary telephone lines.

The DCM-7 accepts data from a computer, converts the data into two-frequency tones and then sends the tones over telephone lines to another modem. Conversely, the DCM-7 accepts tones from telephone lines and changes those tones into data that your computer understands.

This direct-connect, Bell 103-type modem is not only designed with standard automatic dial, answer and disconnect features, but also a wide range of system configuration enhancements as well. Its microprocessing unit (MPU) provides operation in **both Tandy and Hayes protocol modes** — each selectable at the flip of a DIP switch.

In the Hayes protocol mode, your Modem is AT-compatible and capable of running with Hayes software. Special command instructions and registers in Hayes protocol allow you to program the DCM-7 from your computer keyboard for the same operational modes used in Tandy protocol.

For example, you can set the DCM-7 for manual originate or manual answer mode, in which you manually dial the telephone number or answer an incoming call when you are contacting a remote computer. Or you can program the DCM-7 for auto-originate or auto-answer mode and let the DCM-7 dial the telephone number of a remote computer or answer an incoming call. In either Tandy or Hayes protocol, the DCM-7 can be programmed to perform operations such as automatically seizing the telephone line after a specified number of rings and automatically redialing a phone number when communication is not established.

Another feature of the DCM-7 is a built-in monitor speaker which enables you to monitor audibly the dialing and data communication progress. The situation is reported visually on your display with messages called results codes.

Sample programming sessions are provided in each section of this manual to help familiarize you with the various functions of the DCM-7 and to get you started using your Modem as quickly as possible. After you have become familiar with the manual and your Modem, the handy Quick Reference Card should keep you “up-and-running!”

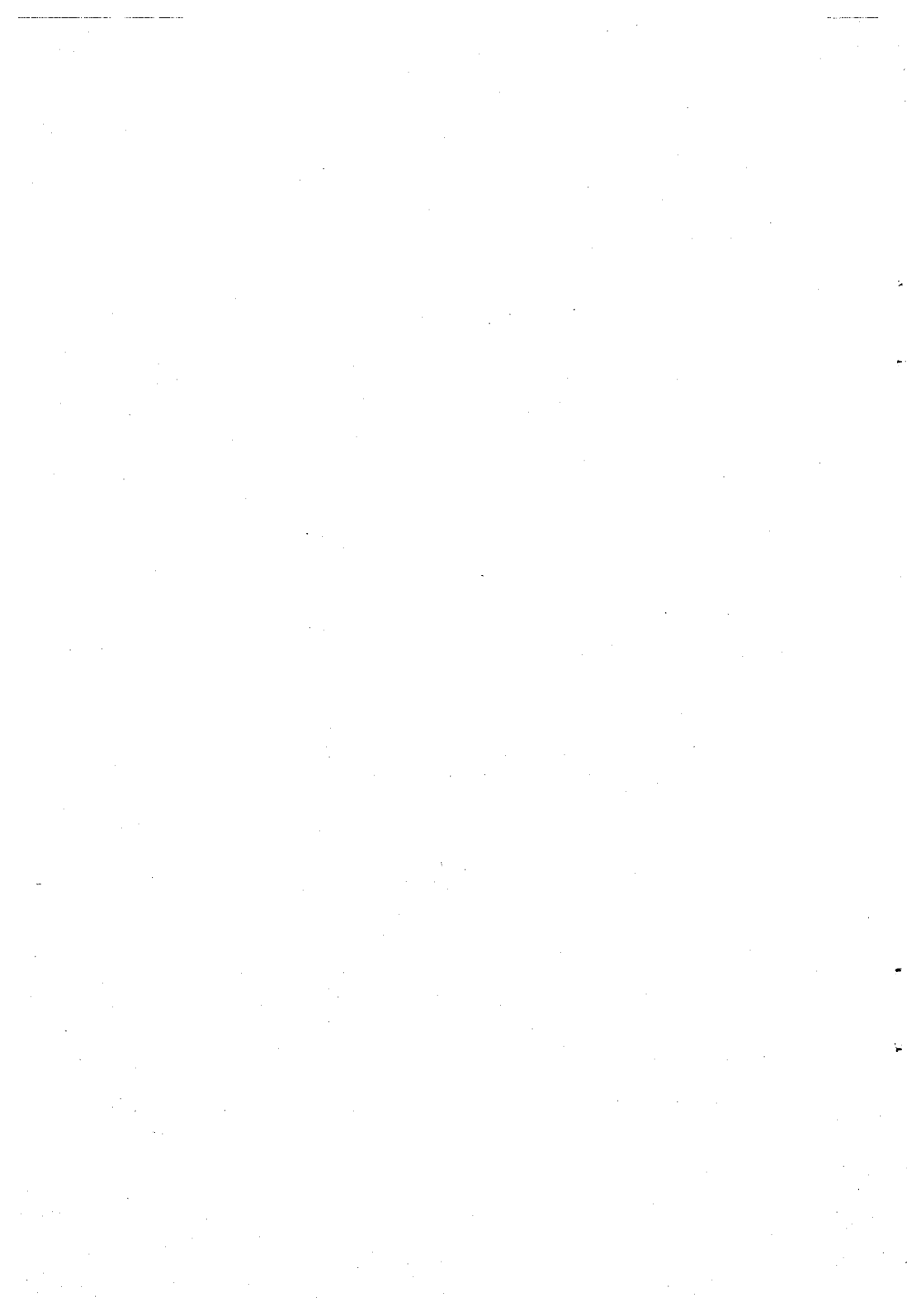

Description of the DCM-7 1

When power is first applied, several of the indicators on the DCM-7's front panel will light — depending on the status of the computer's protocol and DIP switch settings. These 6 indicators show the Modem's internal and external operation status.

- ① **POWER** indicator lights when the power is ON.
- ② **POWER** switch turns the Modem ON or OFF. Be sure to turn it OFF when the Modem is not being used.
- ③ **OFF HOOK** indicator lights when the Modem is ON LINE (connected to the phone line).
- ④ **TERMINAL READY** indicator lights when the terminal is supplying the DTR (Data Terminal Ready) signal.
- ⑤ **CARRIER DETECT** indicator lights when the Modem receives a carrier tone or generates a "false" carrier.
- ⑥ **TRANSMIT DATA** indicator flashes when the Modem is transmitting data.
- ⑦ **RECEIVED DATA** indicator flashes when the Modem is receiving data.

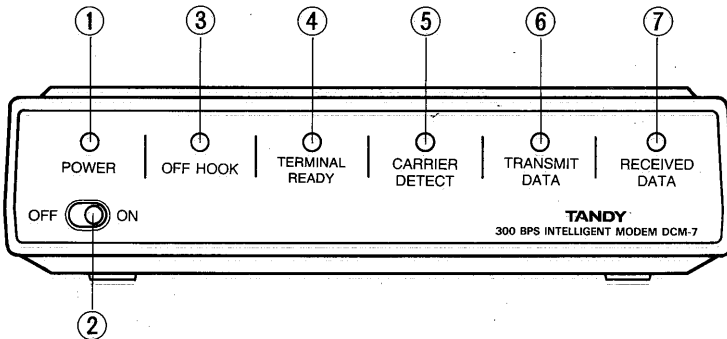

Figure 1. Front Panel View

Description of the DCM-7

- ① **RS-232C standard DB-25 jack** connects the Modem to the RS-232C interface of your computer.
- ② **PROTOCOL (DIP) switches** control the Modem's power-up condition.
- ③ **PHONE jack** connects the telephone to the Modem.
- ④ **POWER jack** connects the Modem to the AC power adapter.
- ⑤ **WALL JACK phone line cord** connects the Modem to the telephone line.

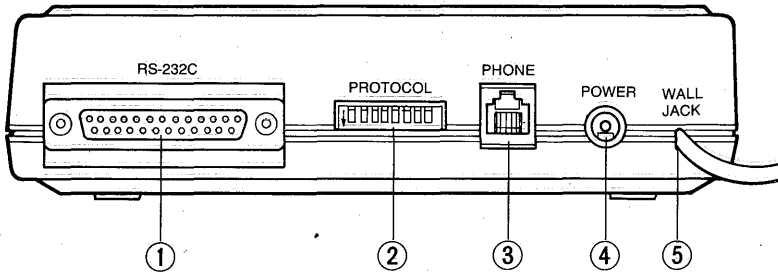

Figure 2. Rear Panel View

Before you connect the DCM-7, first read the instructions in Appendix C, **Connecting the DCM-7**. Be sure to turn OFF the power to the Modem and to the computer!

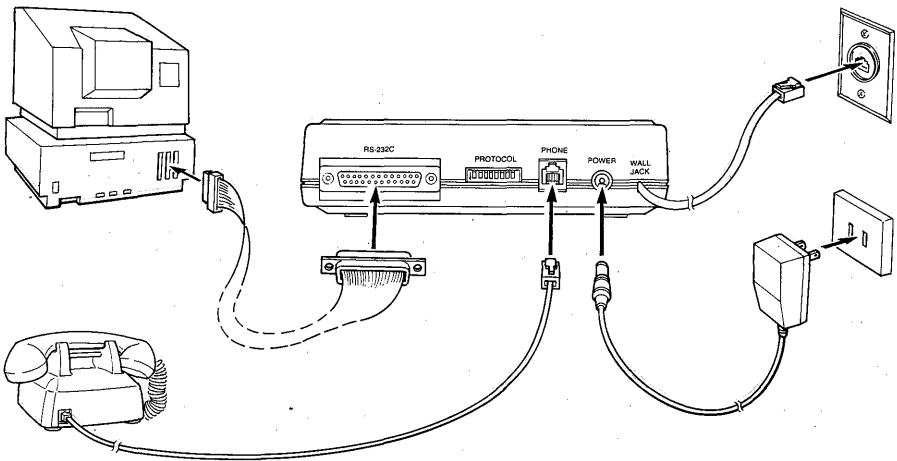

Figure 3. A Typical Connection

Protocol (DIP) switches

DIP switches control the DCM-7's power-up condition. These switches must be set before you turn the power ON.

First, you will have to decide whether you want to use the Modem in the Tandy protocol mode or Hayes protocol mode. If you are using Tandy communications software, you will want to set it for Tandy protocol. For use with Hayes communications software, set it to the Hayes protocol mode. (Both the Tandy 1000 and 1200 and 3000 personal computers can be used with either communications software.)

Tandy protocol

When you select Tandy protocol mode, set DIP Switch 7 to ON. This tells the Modem to set other DIP switch functions as listed in Table 1. Refer to Figure 4 for the suggested switch settings in this mode (black portion shows the switch position).

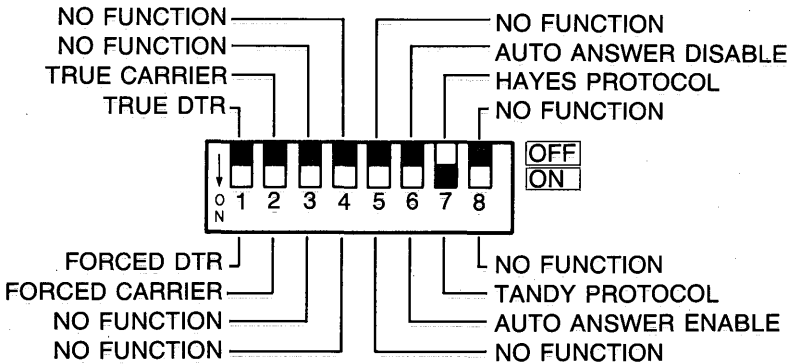

Figure 4. DIP Switch Settings in Tandy Protocol Mode

Table 1. DIP Switch Settings in Tandy Protocol Mode

SW	Position	Function
1	ON	Forced DTR (Data Terminal Ready). Modem accepts command from the local computer without a DTR signal.
	OFF	True DTR. Modem is OFF until it receives a true DTR signal from the computer.
2	ON	Forced carrier. Modem assumes forced carrier detect ^{*1)} and disables the G command.
	OFF	Forced/True carrier. Modem selects between forced carrier detect and true carrier detect ^{*2)} according to the G command input.
3	Should be OFF	No function.
4	Should be OFF	No function.
5	Should be OFF	No function.
6	ON	Auto-answer enable. Modem assumes auto-answer upon power-up.
	OFF	Auto-answer disable. Modem assumes auto-originate upon power-up.
7	Should be ON	Tandy. Sets the Modem to Tandy protocol mode.
8	Should be OFF	No function.

*1) Forced carrier detect ... Modem issues a forced carrier signal to the local computer as soon as power is turned ON.

*2) True carrier detect ... Modem will be off until it receives true carrier from the remote computer.

DIP Switch 2 interlocks with DIP Switch 6 as follows:

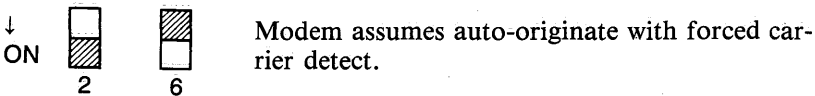
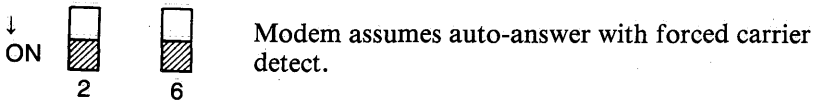

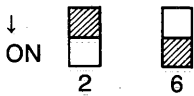

Modem assumes auto-answer with true carrier detect at power-on. The true/forced carrier condition can be changed with the G command.

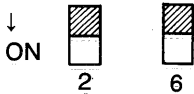

Modem assumes auto-originate with forced carrier detect at power-on. The true/forced carrier condition can be changed with the G command.

Hayes protocol

When you want to use your DCM-7 in Hayes protocol mode, position Switch 7 to OFF. In this protocol mode, the remaining switches function differently from those in Tandy protocol. Refer to Figure 5 for suggested switch settings in Hayes protocol mode.

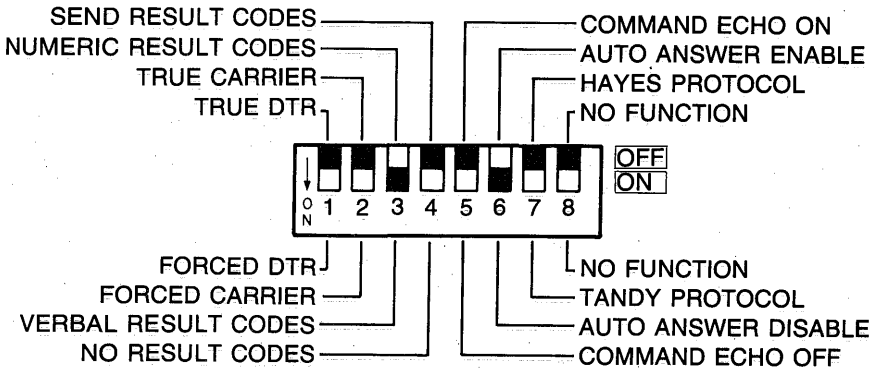

Figure 5. DIP Switch Settings in Hayes Protocol Mode

Table 2. DIP Switch Settings in Hayes Protocol Mode

SW	Position	Function
1	ON	Forced DTR.
	OFF	True DTR.
2	ON	Forced carrier detect.
	OFF	True carrier detect.
3	ON	Displays verbal result codes.
	OFF	Displays numeric result codes.
4	ON	Result codes disabled. Disables Switch 3.
	OFF	Result codes enabled. Enables Switch 3.
5	ON	Command echo disable.
	OFF	Command echo enable.
6	ON	Auto-answer disable.
	OFF	Auto-answer enable.
7	Should be OFF	Sets the Modem to Hayes protocol mode.
8	Should be OFF	No Function.

For easy operation, position Switch 5 to OFF to echo the command line. Set Switch 4 to OFF and Switch 3 to ON to send the verbal result codes to the screen.

Communications protocol

The following criteria must be met before computer-to-computer communication can occur.

1. Both computers must have the same communications protocol:

- 300 bits/second (Bps)
- Word length (7 bits or 8 bits)
- Parity (even, odd or none)
- Number of stop bits (1 or 2 bits)

See your computer owner's manual for instructions on setting the communications protocol.

2. One modem must be in ORIGINate mode and the other must be in ANSwEr mode. Usually, when you call another computer, you should be in ORIGINate mode. When you receive a call, you should be in ANSwEr mode.

The DCM-7 provides automatic and manual operations in both originate and answer modes. When opened for programming by the wake-up or attention code sequence, it will automatically synchronize the speed rate, word length, parity and stop-bit numbers (communications protocol) of your computer system.

Helpful Tip:

When you use your DCM-7 for the first time or when you seem to be getting garbled data, use the self-test mode to help you find the cause of the problem. Refer to the section on **self-test** in Appendix A, **Tandy protocol reference** or in Appendix B, **Hayes protocol reference**.

If you plan to use the DCM-7 in Tandy protocol mode only, you may skip Chapter 3 and Appendix B. However, if you intend to use it in Hayes protocol mode only, you may disregard Chapter 2, and Appendices A and D. Refer also to the operation manual which accompanies your communications software package.

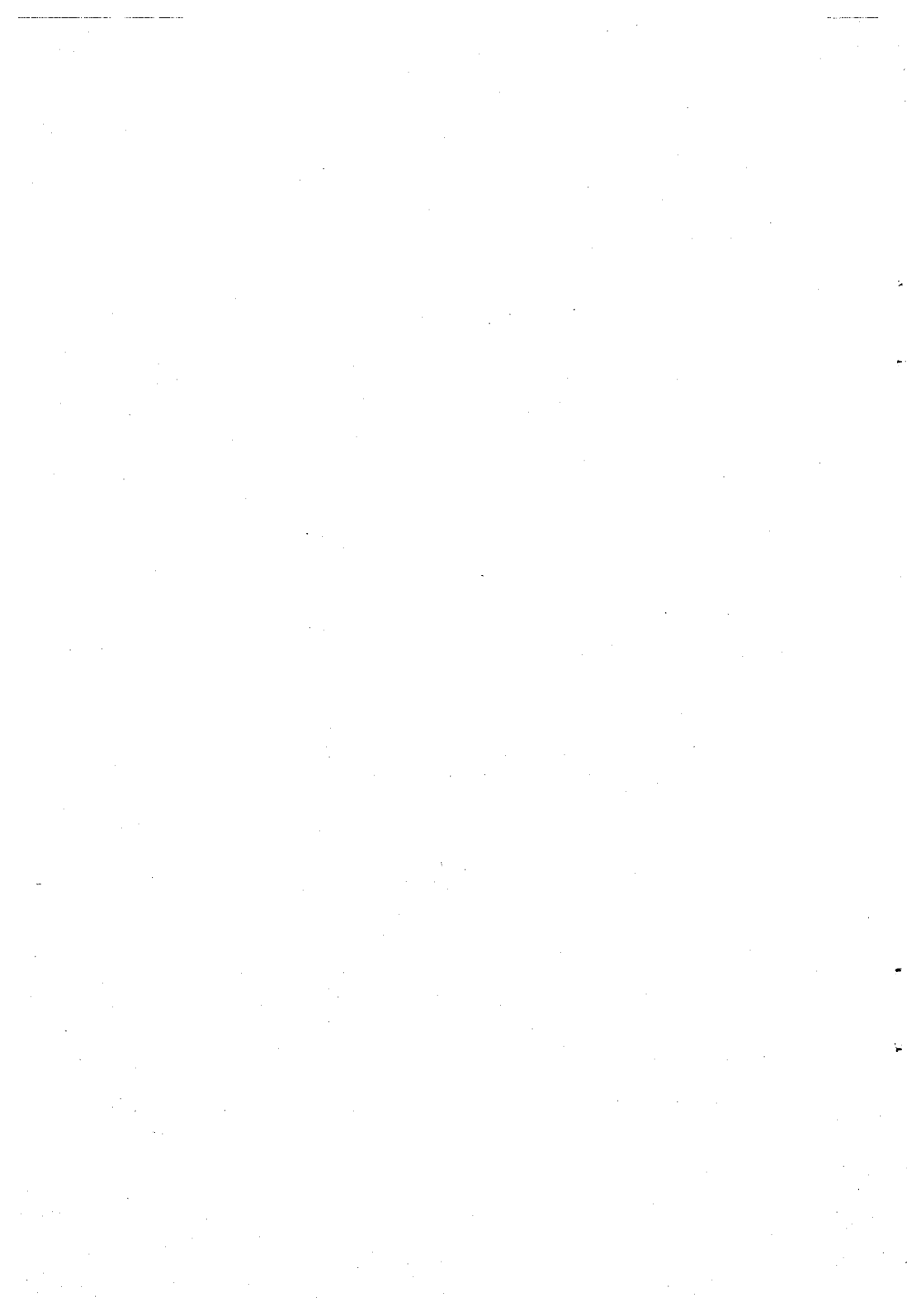

Tandy protocol mode operation 2

This chapter will give you an idea of what the DCM-7 can do in the Tandy protocol mode. A Videotex Plus communications package for Tandy's Model II, 12, 16 and 6000 microcomputers is used in the sample sessions following. With this software package you can communicate with a variety of information services and host computer systems. The examples will help familiarize you with some of the operations the Modem is capable of performing.

If you are using an MS-DOS operating system, move directly to the auto logon session using DeskMate's Telecom in Chapter 3, **Hayes protocol mode operation**. XENIX users may want to skip to Appendix D.

For a detailed discussion of all the available commands in Tandy protocol, refer to Appendix A.

Manual v. automatic operation

When you want to dial an information service (such as CompuServe or Dow Jones) or communicate with another person whose computer is also using VIDTEX, set the Modem to manual operation mode. In this mode, you can control what the system does by manually dialing and answering the phone.

When you want the DCM-7 to dial a phone number or answer the phone for you, set it to automatic operation mode. In this mode, the Modem dials the phone number you store in its memory or answers the phone when someone calls you. Automatic mode, for instance, lets you dial the information service number without picking up the phone — just type the number along with the proper DCM-7 programming commands on the computer keyboard.

Originate v. answer mode

To place a call to an information service or another person using VIDTEX, set the DCM-7 to originate mode. In this mode, the call originates from your computer. When you want to receive a call (answer the phone), set the DCM-7 to answer mode. Note that originate and answer modes can be used either manually or automatically.

Sample programming sessions

All Modem functions are controlled by ASCII encoded commands that you send from your computer keyboard. Use the wake-up command * to open the DCM-7 for programming.

1. Check again that all peripherals are correctly connected and receiving power.

Tandy protocol mode operation

2. Set the DIP switches as follows:

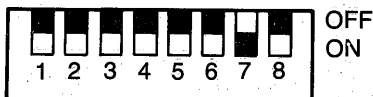

3. Flip the Modem's power switch on the front panel to the ON position.
4. Load and run the Videotex Plus communications program. Refer to your Videotex user's guide as well.
5. At TRSDOS Ready, type VIDTEX (ENTER) . *TERMINAL READY indicator lights.*
6. Set the communications protocol. Be sure the operation speed is set to 300 Bps.
7. Open the Modem for programming by pressing * for the wake-up command.

The Modem is now in the command receptive state and is waiting for you to begin programming or setting the internal switches that will tell it what operations are to be performed.

8. When the * echoes on your computer screen, enter LIST command L to display or list the Modem's current parameters. When the Modem is turned on, the list shows:

MODE = A	Automatic
TYPE = O	Originate
F CD = Y	Forced Carrier Detect ON
SPKR = Y	Monitor speaker ON
ANSW = 2	2 rings before Auto Answer
DTRY = 1	1 automatic dial try
TEST = N	Test mode OFF
NUMB =	Telephone number stored in memory
RATE = S	Slow Dialing rate
EXIT = 0F	Exit communication upon receiving <CTRL> <O> (ASCII 0F)

Note: The default parameter of line F CD = varies with the position of DIP switches 2 and 6.

After the parameters are listed, the Modem returns to the command receptive state where it waits for further instructions.

CompuServe logon

CompuServe Information Service is widely known for its numerous on-line services for both business and home computer owners. Dedicated telephone numbers in major cities provide you access to CompuServe. Use your information service user's guide to find out how to contact and use the service.

Since the DCM-7 is already in the command receptive state — waiting for your command — all you have to do to begin the logon is prepare the Modem to dial the information service access number.

1. Press **D** to place the Modem in the dialer programming mode. For example, if you enter (111)555-1234 as your local access number for touch-tone dialing, the sequence appears as:

DT(111)555-1234

If you're using a rotary (pulse) type telephone, type **R** instead of **T**.

2. When the phone number is properly formatted (see **D command, Tandy protocol reference**), press **X** to force the Modem to seize the telephone lines and to begin dialing the number. *OFF HOOK indicator lights.*

The screen shows:

DIALING ... T(111)555-1234
CONNECT

Dialing . . . and connect are the **Result codes** (discussed later in this section) which keep you informed of the status or progress of a phone call. If you received a? instead of the message shown, you probably entered a key that the Modem did not recognize.

3. Press **CTRL C** and type the User ID number that you received with the software package when the screen prompts:

User ID:

4. Next, type the password that you received with the software package when the display prompts:

Password:

Your password is not printed on the screen to retain its secrecy.

At this point, your logon to CompuServe is complete and you may begin using the service. To use other information services and host systems, simply substitute the appropriate dialog as provided in the information service user's guide.

Manual mode operations

When operating in manual mode, you control the system by manually dialing and answering the telephone. Manual mode (answer or originate) is useful when you want to talk by telephone to a friend at a remote location, and later exchange computer data without redialing.

Example 1. Manual answer mode

The phone rings and you answer by picking up the receiver. After talking a while to your friend, you decide to exchange information by computer (telecommunications) without breaking voice call:

1. Your friend selects to be the originating station, while you are the answering station. Set up your Modem by entering:

*	Wake up!
M	Select manual mode.
A	Select answer mode.

2. Give your friend time to set up the originating modem.
3. Press (X). The Modem transmits carrier tone. The carrier is the sound you hear through the built-in speaker or when you pick up the receiver while the Modem is in communication with another modem.
4. The answer station always issues the X command first. After hearing the answer modem's carrier tone, the originate station sends the X command to complete the connection. The Modem goes on line, and you'll see the CONNECT result code on the screen.
5. Hang up both handsets.

Be sure to keep quiet when the handset is OFF HOOK. Noise picked up could cause errors in the data being passed by the modems.

Be careful when you hang up the telephone since slamming or dropping the phone back on the hook while the modems are controlling the lines could disrupt carrier long enough to start a loss-of-carrier disconnect sequence.

To return to voice communications after transmitting data:

1. Carefully pick up the handset (both modem stations).
2. Type at the keyboard that you will be aborting carrier. For example, you might signal your friend by typing:

THAT'S ALL! I AM ABORTING CARRIER.

3. After making sure your handset is OFF HOOK, enter the abort character (CTRL) (O) to force the Modem OFF LINE. If your computer does not have the CTRL key, refer to your computer manual to find out the key of hex value 0F, or change the abort character using abort character redefinition @. Refer to Appendix A, @ command.

After 3 seconds of inactivity, your Modem logs out with the DISCONNECT result code, and your friend's modem (if automatic) shuts down, too. The Modem is in OFF-LINE mode. Press (*) to return to the command receptive mode.

Example 2: Manual originate mode

1. Set the Modem for manual originate mode. Press (M) for manual and (O) for originate. Then, press (L) to check the current parameter settings. The first two parameters should show:

```
MODE = M
TYPE = O
```

2. Now pick up the telephone and dial the information service phone number. When the information service answers the phone, you will hear a high-pitched tone.
3. Press (X). The OFF-HOOK indicator lights. As soon as the Modem detects the carrier tone, it issues low-pitched tone. Then it goes ON LINE and sends the CONNECT result code to the screen.
4. Gently hang up the phone. You can then begin following the instructions detailed in your Videotex and information service user's guides.

Automatic mode operations

The DCM-7 can be programmed to make a call or answer your telephone automatically. In automatic mode operation, you can call an information service without picking up the phone — just type in the phone number on your computer keyboard. You can also tell the Modem to auto-answer your telephone.

Example 3: Automatic answer mode

1. To set the Modem for automatic mode, first type * to enter command mode, then type L to display the current parameter settings. If screen shows MODE=M, then press (M) for automatic mode. Type L to confirm that the mode is now A for automatic.

2. Type **A** to set the Modem to the answer mode if the **TYPE** parameter does not show the value **A**.
3. Press **(X)** to force the Modem out of command receptive state and into auto-answer mode. The Modem will then wait for the telephone to ring and sends:

WAITING FOR RING

4. When the phone rings, the Modem begins counting the rings and sends the **RING** result code to the display for each ring. After 2 rings, it answers by seizing the telephone line and asserts carrier. The calling modem replies with its carrier. Both modems are now **ON LINE** and telecommunications can begin.

The ring number is set to 2 at power-on. This means your Modem will seize the phone line after 2 rings. When you want to change this number, press **(1)** for the ring change command when the Modem is in command receptive mode. The display prompts:

ANSWER ON 1-9 RINGS OR CR FOR NO CHANGE =

When you do not need to change the number of rings, answer this prompt by pressing **(ENTER)**, which is the **CR** (Carriage Return) key. To change the ring number, type in the new number. Note that only a number key or the **ENTER** key is accepted. If you press any other key, the DCM-7 will "echo" the typed key (if displayable) and ask the question again.

If the key you press is a valid entry, the Modem sends the next prompt:

RETRY FOR 1-9 TIMES OR CR FOR NO CHANGE =

For the time being, press **(ENTER)** to skip.

If either modem breaks the connection after a successful data exchange with the abort character, the DCM-7 will send the **DISCONNECT** result code, then the **WAITING FOR RING** result code. This means it returns to auto-answer mode and monitors the line. As long as the Modem is in auto-answer mode, it will continue to monitor the telephone line for an incoming call. You can turn **OFF** this call-waiting mode by pressing **(*)**. When the Modem detects the *****, it will change to auto-originate mode and return to the command receptive state.

Example 4: Automatic originate mode

1. Follow the procedure in Step 1 of Example 3, **Automatic answer mode**.
2. Type **O** to set the Modem to originate mode if the **TYPE** parameter does not show the value **O**.

3. Enter the telephone number you want to dial using the D command (See Appendix A, **Dialer programming mode**). You can also specify the dialing method (either pulse or touch-tone), the dialing speed and any pause which may be necessary to access an outside line in a PBX. For example, in the phone number below:

DT9P1234567

T indicates tone, 9 is the access code to the outside line, P is the 2-second pause and the digits 1234567 are to be dialed. For more information on storing a telephone number, refer to Appendix A.

4. Press (X) to force the Modem out of command receptive state and to begin dialing the number.
5. After detecting the carrier tone of the answer modem, after the telephone line is connected, the Modem is ON LINE.

If the Modem does not detect the carrier tone of the answer modem within 30 seconds after dialing (due to busy or no answer condition, etc.), it goes off line after sending the NO CARRIER and DISCONNECT result code. To dial the number again, press (*) (X). The Modem automatically dials the number stored in dialers memory. If you press (X) without having stored a number, the Modem displays the NO NUMBER result code.

You can also program the Modem to automatically redial (RETRY) the number in advance. In this case, press (1) for the dial retry command. After you respond to the first prompt, a second prompt appears:

RETRY FOR 1-9 TIMES OR CR FOR NO CHANGE =

Again, a valid entry is a number or (ENTER). Input the desired number of tries. If no change is required, just press (ENTER).

Analog self-test mode

Type Q, then type L to confirm that the value of the TEST parameter is now changed to Y. Type X to execute the test command. The Modem displays CONNECT and you are in the self-test mode. Type any characters on the keyboard. If the DCM-7 is working properly, the TRANSMIT DATA and RECEIVED DATA indicators blink simultaneously and the characters you typed will appear on the display. If not, there are problems with the circuit. Check all cables and connections and run the test again. To abort self-test mode, press (CTRL) (O) for the abort character.

Always auto-answer mode operation

The Modem assumes always automatic answer mode operation when the DIP Switch 6 is set to on at power up, and begins monitoring the telephone line. When you type * , the Modem enters command receptive mode and changes to automatic originate mode as in normal automatic answer mode. After disconnecting, or after receiving the C (clear memory) command, the Modem returns to automatic answer mode.

This setting is useful when you use the Modem mainly in the answer mode.

On-line abort conditions

After establishing communications with a remote modem, the DCM-7 is in monitor mode. In this mode, the parameters are constantly scanned. If any one of these parameters fails, the DCM-7 will break communications and go OFF LINE immediately. The parameters monitored include loss of carrier, the abort character and space disconnect.

Loss of carrier

The carrier monitored is the one that is sent over the telephone line, not the false carrier generated by the DCM-7. In all modes, except TEST, if carrier is removed for longer than 0.3 seconds, the Modem will exit monitor mode and drop the phone line. If the carrier interruption is less than 0.3 seconds, loss of carrier is ignored.

In automatic originate mode, when the Modem is waiting for a call to be completed (a 30-second delay time between dialing and disconnect where the DCM-7 is looking for a valid carrier signal), you can command the DCM-7 to abort the call by inputting any keys including *. If you aborted with other keys, press **(*)** to set the Modem to command receptive mode.

Manual abort entry

When you send a CTRL O (0F HEX) or another character you programmed with the @ key and do not send any other character for 2 seconds, the DCM-7 will exit monitor mode.

DTR (Data Terminal Ready) is also scanned in this mode. If the DTR is OFF, the DCM-7 will terminate communications, just as if the carrier had failed.

Space disconnect

Your DCM-7 will drop the phone line any time it receives a continuous RS-232C SPACE (ASCII BREAK or null with no start and stop bits) for 3 seconds from the remote modem or for 1.5 seconds from your computer. This is called space disconnect and is in accordance with Bell 103J standards for short and long space disconnect.

To regain control over the Modem after disconnection, input wake-up code *. The Modem returns to the command receptive state with the same parameter settings as before. When you want to change the parameters to the default settings, press (C) .

Note: The clear memory command C sets the Modem to off-line mode. Press (*) again to enter command receptive mode.

Result codes

The DCM-7 sends the result codes to report its status or telephone line condition.

Table 3. Result Codes

Result Code	Meaning
?	The command input is invalid.
NO NUMBER	There's no number to be dialed in the memory.
DIALING ...	Modem is dialing the number that follows.
CONNECT	Detected carrier and goes on line.
NO CARRIER	Does not receive carrier or lost it.
DISCONNECT	Goes on hook after the connection.
WAITING FOR RING	Modem is monitoring the telephone line for a ring signal.
RING	Detects an incoming ring signal on the telephone line.
FORCED CD SWITCH IS ON	Since DIP Switch 2 is ON, Modem does not accept G command (Refer to Chapter 1 Protocol (DIP) switch.)

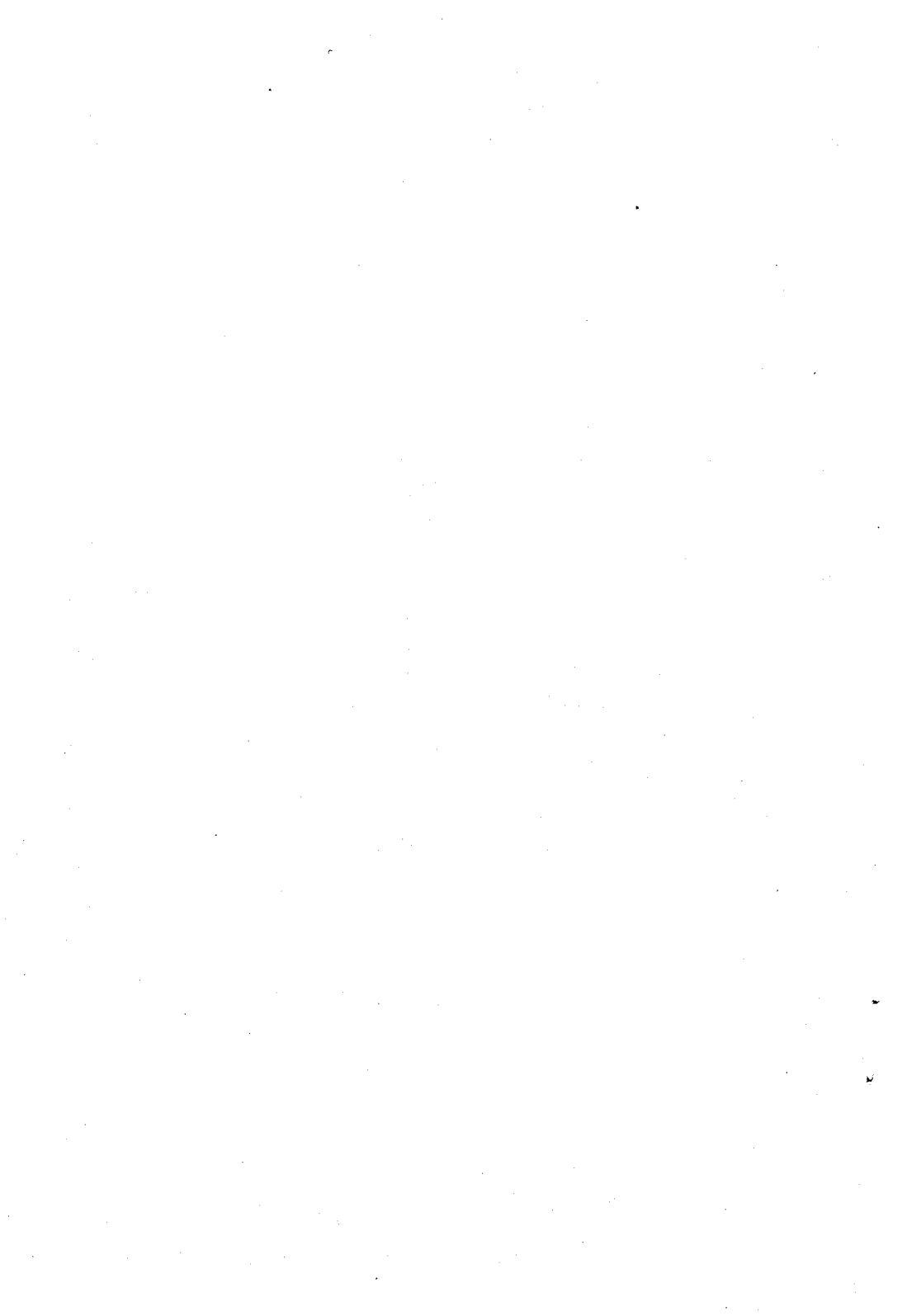

Hayes protocol mode operation 3

In Hayes protocol mode, commands instruct the DCM-7's operation and register values determine how the commands will be executed. The command structure is patterned from the industry standard AT-string-interface command, which makes the DCM-7 Hayes-software compatible.

Command codes

All command lines in Hayes protocol mode begin with the AT (attention code) string and end with a carriage return (ENTER). AT must be entered in uppercase letters, but the commands following can be entered in either upper- or lowercase letters. When the AT command is received, the DCM-7 will automatically set the operation speed (in Bps) and parity.

You can store a sequence of commands in the command buffer memory, provided the command line does not exceed the 40-character buffer capacity. These commands, however, must be entered in logical order in order to be executed. If the command line exceeds the buffer-character limit, the Modem will not execute the commands and instead sends an error result code (Table 8).

Example 1. Sample command line

AT V1 S6=3 DP9, T(111)123-4567R (ENTER)

Now, to review the commands, one by one:

AT	Beginning of command line. Place the Modem in command receptive mode.
V1	Display the verbal result code. (Refer to Result codes later in this chapter.)
S6=3	Wait 3 seconds for the dial tone.
DP9,	Dial 9 by pulse dialing, then pause 2 seconds (default value of register S8). (Refer to the section on Registers .)
T	Touch-tone dial the telephone number that follows.
R	Change to answer mode and wait for carrier.
(ENTER)	End of command line. Execute all commands.

The attention code AT, control characters and spaces do not take up space in the command buffer. The punctuation used in the telephone number to make it easier to read does take up space. Input the attention code AT, reset command Z, or turn OFF the power supply of the Modem to clear the command buffer.

The basic commands needed for programming the Modem in Hayes protocol mode are provided in Table 5. Table 6 lists the dialing and answering commands. For a detailed explanation of each command, refer to Appendix B, **Hayes protocol reference**.

Commands with parameters

Some of the commands have parameters. The parameter value, usually 0, 1 or 2, follows the command. When the command parameter is not used, the Modem assumes a value of 0. For example, the echo command E does not echo when parameter 0 is assumed. It does echo when parameter 1 is issued. E used alone is the same as E0.

Table 4. Commands with Parameters

Code	Parameter	Function	Default
Q	0	Result codes ON.	Defined by DIP Switch 4.
	1	Result codes OFF.	
V	0	Numeric result codes.	Defined by DIP Switch 3.
	1	Verbal result codes.	
E	0	Commands are not echoed.	Defined by DIP Switch 5.
	1	Echo commands.	
F	0	Half duplex.	F1
	1	Full duplex.	
M	0	Monitor speaker always OFF.	M1
	1	Monitor speaker ON until carrier-detect.	
	2	Monitor speaker always ON.	
C	0	Transmitter OFF.	C1
	1	Transmitter ON.	
H	0	ON HOOK (phone line is disconnected when not in use).	H0
	1	OFF-HOOK (phone line is connected regardless of its condition).	

Table 5. Basic Command Codes

Code	Description	Function
AT	Attention Code	Wakes up the Modem to command receptive state. Starts the command line.
CR	Carriage Return	Closes the command line and executes commands. Register S3 defines the carriage return character.
BS	Backspace	Edits the command line by deleting characters one by one. Register S5 defines the backspace character.
+++	Escape Code	Returns the Modem to command mode from on-line mode. Register S2 defines the escape code character. S12 defines the escape code guard time.
O	On-line	Returns the Modem to on-line mode from command mode.
Z	Reset	Resets the Modem to default condition.

Table 6. Dialing and Answering Command Codes

Code	Description	Function
D	Dial	Sets the Modem to originate a telephone call. D command parameters include: 0-9, (), space, *, and #.
P	Pulse Dial	Sets the Modem to pulse dialing mode.
T	Touch-tone Dial	Sets the Modem to touch-tone dialing mode.
R	Reverse Mode	Automatically changes the Modem to answer mode after a call is originated.
,	Pause	Causes the Modem to pause while dialing. Follows the access code. Length of pause is set by Register S8.
(comma)		
;	(semicolon)	Returns the Modem to command mode after dialing.
A/	Repeat Command	Repeats the command line. AT and ENTER are not necessary for this command.
A	Answer Mode	Immediately sets the Modem to answer mode without waiting for a ringing signal.

Registers

Registers are used to store the parameters which control communications. Each register has variables that determine how the DCM-7 operates or supplies information on the Modem's current condition. The DCM-7 has 14 registers:

Table 7. Registers

Register	Range	Unit	Function	Default
S0	0-255	Ring	Defines the rings in answer mode.	0 ^{*3)}
S1	0-255	Ring	Counts the rings.	0
S2	0-127	ASCII code	Defines the escape code character.	43
S3	0-127	ASCII code	Defines the CR code character.	13
S4	0-127	ASCII code	Defines the LF code character.	10
S5	0-32,127	ASCII code	Defines the BS code character.	8
S6	2-255	Seconds	Defines the dial tone wait time.	2
S7	1-255	Seconds	Defines the carrier wait time.	30
S8	0-255	Seconds	Defines pause duration for comma (actual maximum value is 54, but a value up to 225 can be input).	2
S9	1-255	1/10 sec.	Defines carrier detect response time.	6
S10	1-255	1/10 sec.	Defines carrier loss time to hang up.	7
S11	50-255	Millisec.	Defines touch-tone dialing speed.	70
S12	20-255	1/50 sec.	Defines escape code guard time.	50
S13-S15			Not used.	
S16	0		Self-test mode OFF.	0
	1		Self-test mode ON.	

*3) When DIP SW 6 is OFF, the Modem will power-up in auto answer with S0 = 1.

Register S0 defines the number of ringing signals before a call is answered; register S1 counts the rings; registers S2-S5 define the function key characters; registers S5-S12 control the function time and register S16 is for the self-test.

Note: The ASCII code values are expressed in decimal.

Command syntax

You can read the current value of a register or assign a new value to match the registers to your particular environment by using the $Sx?$ or $Sx=n$ command syntax.

 $Sx?$ Check the register value

To check the value of a register, use the $Sx?$ syntax. The value of the registers are displayed on the screen in decimal numbers. For example, to check the value of register S2, type:

AT S2?

On the screen, you will see —

043
OK

You can also check the values of plural registers in the same command line. To check the values of register S3 and register S4, type:

AT S3? S4?

The screen might show:

013
010
OK

 $Sx=n$ Change the register value

Use the $Sx=n$ syntax to assign or change the value of a register. To assign the value 3 to register S0, type:

AT S0=3

After changing the value, the Modem signals OK. Another syntax for changing a register value is:

AT S0

Set the pointer to register S0.

AT ?

Read the value of S0.

AT=3

Assign the new value 3 to S0.

For more information on the registers, refer to Appendix B, **Hayes protocol reference**.

Result codes

Result codes are displayed in either numeric or verbal code after the command line is executed.

Command Q determines whether the result codes will be displayed. When Q1 is selected, the result codes will not be displayed. When Q0 is selected, you can see the codes on the screen. Command V selects either numeric (V0) or verbal (V1) codes.

The default values of these controls are fixed by DIP switches. For example, when DIP Switch 4 is set to ON, the result codes do not appear on the screen unless Q0 is entered from the keyboard. (Refer to Chapter 1, **DIP switches**).

Table 8. Result Codes

Numeric	Verbal	Meaning
0	OK	Executed the command line without errors.
1	CONNECT	Detected carrier.
2	RING	Detected an incoming phone line ring signal.
3	NO CARRIER	Carrier was lost or never heard.
4	ERROR	Error in the command line, command is invalid (not recognized by the Modem), or the command line exceeds command buffer size.

Logons in MS-DOS operating systems

With DeskMate's Telecom applications program and your Tandy Personal Computer, you can easily program your DCM-7 to log on to a host computer, information service or another terminal either manually or automatically. Follow the instructions in your DeskMate Tutorial and Reference manual for setting the parameters and using the functions available. Depending on the computer you are using, the procedures may differ slightly from those shown. A Tandy 1000 PC is used for the examples following.

1. Power up the computer and load your communications software. Set the DIP switches on the DCM-7 as follows:

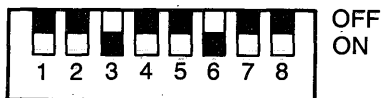

- At the Main Menu, select Telecom and change the TELECOM-STATUS screen to show:

Autodial Modem	Yes
BAUD Rate	300
Data Word Length	8 BITS
Parity	NONE
Number of Stop Bits	1 BIT
XON/XOFF Flow Control	ON
ASCII Character Filter	OFF
Line Feed Filter	OFF
Echo (Half Duplex)	OFF
Redial (# of Retries)	0

- Select "Yes" for the Autodial Modem status setting and press (F2). When the DEFINE MODEM FOR COMPUTER DIALING screen appears, change the dialing sequence to show:

PAUSE: 2	Pause for 2 seconds.
SEND: ATDT	Wake up and originate a call using touch-tone dialing.
NUMBER	Send number which will be input at terminal mode.
SEND: ^M	Send ^M to force the DCM-7 to execute the commands:
WAITC	Wait for carrier detect before continuing.

Note: If your telephone system requires pulse, rather than touch-tone dialing, change ATDT to ATDP in the first SEND line.

- Press (F12) twice to return to the TELECOM-STATUS screen after saving the dialing sequence.

Manual logon

- Enter terminal mode from the TELECOM-STATUS screen (F5).
- At the TERMINAL MODE screen, press (F8) and type in the telephone number of the information service, then press (ENTER) .
- After the connection has been made successfully, proceed with the logon procedures step by step.

Automatic logon .

1. At the TELECOM-STATUS screen, press **(F4)** to create an autolog file and enter your log file name, then press **(ENTER)** . Press **(F1)** to create the STATUS line. After selecting the parameters, press **(F12)** to return to the original screen and complete the rest of file. When completed, the screen for your autolog file might show:

```
STATUS: Y, 30, 8, N, 1, ON, OFF, OFF, OFF, 0
CALL: 123-4567 (Use your local TELENET number.)
PAUSE: 5
SEND: ^M^M
RECV: TERMINAL =
SEND: D1^M
RECV: @
SEND: C 60942^M
RECV: ????
SEND: DJNS^M
```

2. Press **(F12)** **(ENTER)** to save this autolog file and return to the TELECOM-STATUS screen.
3. Input **(F3)** filename **(ENTER)** to execute your autolog file. When the logon sequence is entered correctly, the DCM-7 will dial your local access number, connect to the service, then automatically execute the rest of the autolog file.

Appendices

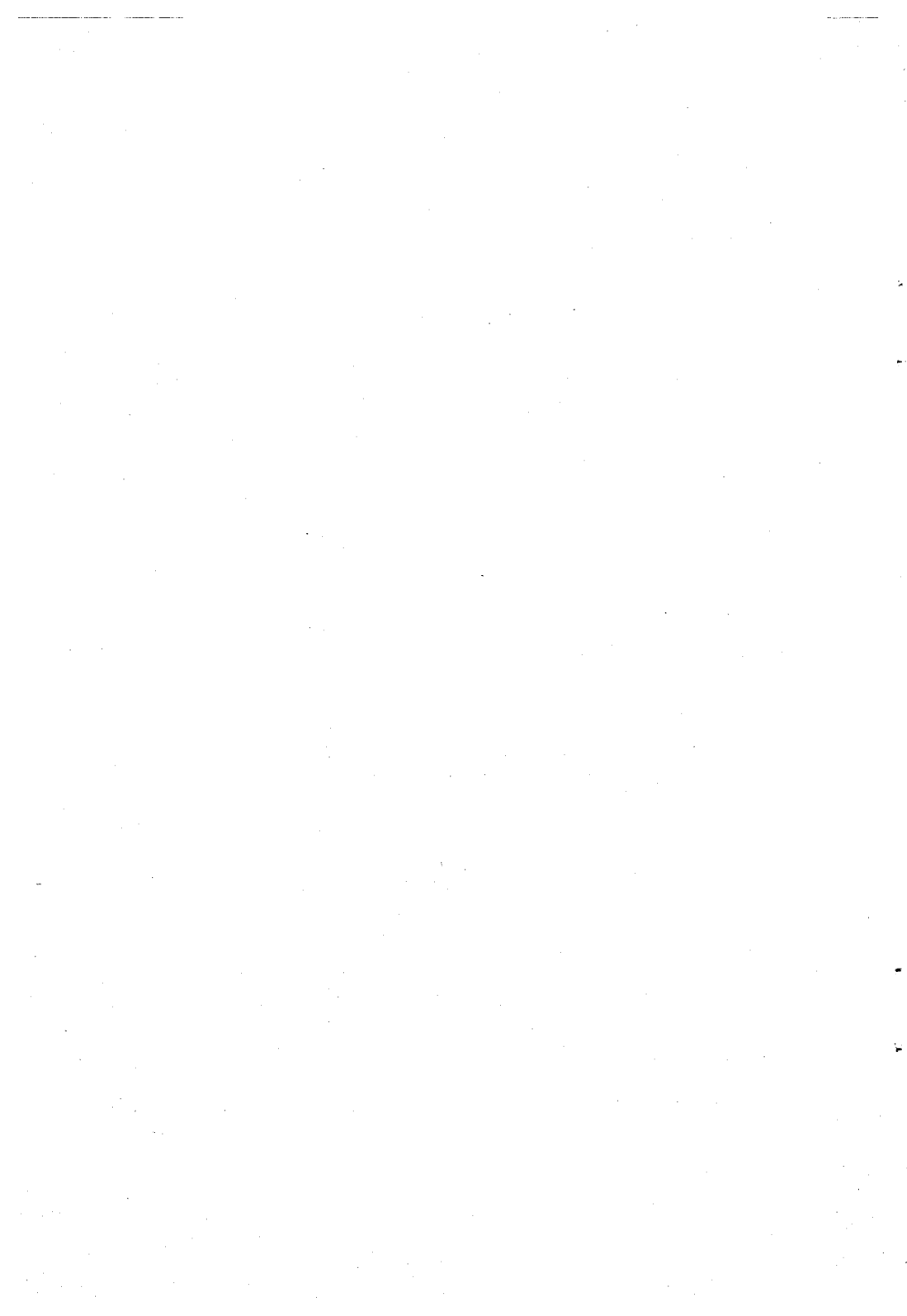

Tandy protocol reference **A**

When you use your DCM-7 in automatic mode, you don't have to dial any numbers or pick up your telephone receiver to answer a call — your DCM-7 does all that for you. As long as you're going to be at your computer throughout communications, you can control the DCM-7 and your telephone through your computer keyboard.

You can also send or receive data from another computer while you are not at your computer keyboard. Just write a BASIC or machine-language program and use the commands to program your DCM-7 to dial a number (automatic originate) or answer (automatic answer) the phone unattended. By programming your DCM-7 to download daily information to another computer after 12 midnight, for example, you'll save time and be able to take advantage of lower telephone rates.

The DCM-7 is completely programmable using the commands shown in Table 9. These commands can be entered either in upper- or lowercase letters.

Table 9. Programming Commands

Command	Description	Default
*	Wake up command	
@	Redefine abort character	CTRL O (HEX 0F)
A, a	Answer mode operation	Originate mode
C, c	Clear memory	
D, d	Enter dialer programming mode	
P, p	Pause subcommand	
R, r	Pulse (Rotary) dial subcommand	
T, t	Touch-tone dial subcommand	Pulse (Rotary)
E, e	Command echo disable/enable toggle	Echo enable
F, f	Fast dialing speed	Slow dialing
G, g	Forced carrier detect toggle	DIP Switch 2/6
I, i	Ring/Retry change command	Ring 2/no retry
L, l	List parameter settings	
M, m	Manual/automatic toggle	Automatic
O, o	Originate mode operation	
P, p	Monitor speaker ON/OFF toggle	Speaker ON
Q, q	Self-test command	
S, s	Slow dialing speed	
X, x	Execute command(s)	

Command description

This section details how to program the DCM-7 using the commands listed in Table 9.

*** Wake-up command**

This command is used to wake up the DCM-7 — that is, switch from the off-line state and into the command receptive state. At initial power-up, you will need to precede any command with the *.

The wake-up command is also used to (1) abort (turn off) the dialing process; (2) abort the waiting-for-carrier state (after dialing is complete); and (3) interrupt the waiting-for-ring state when the DCM-7 is in auto-answer mode.

When the * is used while the DCM-7 is waiting for a telephone call (phone to ring), it terminates the answer mode.

When used while the DCM-7 is dialing in automatic originate mode, the Modem will stop dialing, displays DISCONNECT and return to the command receptive mode.

The * command can be used at any time while in command mode. It will be echoed to the computer, but no action will occur.

@ Redefine abort character

The abort character allows the Modem to be disconnected under software control. With this command, you can change the default abort character CTRL O into any ASCII character you like.

To program this symbol, press @ . The next key the Modem receives will be stored as the abort character. For example, to change the abort code from CTRL O to CTRL R after doing a List command, you would type:

@ CTRL R

CTRL R would be listed as EXIT = 12 (in HEX). When you enter the ASCII character, it will not be echoed on the screen. Only @ will be echoed, provided the echo switch is not disabled.

The DCM-7 will watch for transmitter activity for 3 seconds after the abort code is sent. If there is no activity during that 3-second period, the computer will abort any ON-LINE activity in progress. If there is keyboard activity within that 3-second period, the DCM-7 will ignore the abort command.

A, a Answer mode operation

The Modem is defaulted to operate in originate mode when first powered up. The A command is used to change the DCM-7 from an originate modem to an answer modem. Use the answer mode when you want to receive a call from a modem which is operating in originate mode. The M command (manual/automatic toggle) determines whether the Modem will wait for the telephone to ring (auto answer) or seize the telephone line as soon as you exit the command receptive state with the X (manual answer).

You can enter this command repeatedly. There is no harm in entering A when the DCM-7 is already in answer mode. You may want to put A in your applications software to be sure the DCM-7 is in answer mode before running the program.

C, c Clear memory

The C command clears the DCM-7's memory and resets all the parameters to the default values. There is no need to follow the C command with the execute command (X), because the memory is cleared immediately when © is pressed. After this command is issued, the DCM-7 returns to off-line mode. Use the wake-up command (*) to enter the command receptive mode.

You can use the C command when you have changed several parameters and you do not want to go back and change each one. It also saves you from having to cycle the power switch OFF and ON.

D, d Enter dialer programming mode

Use this command to enter the dialing parameter setting mode. When you enter the D command, the dialer memory is cleared and the DCM-7 waits for the following subcommand entries:

0-9, *, # *(Telephone number and code)*

These must be valid digits that can be dialed on the phone. The * and # are used only in the touch-tone dialing mode for special service.

P, p *Dial pause subcommand*

Wait here for 2 seconds before dialing the rest of the digits. You may need to enter this command to access an outside line when your phone is located behind a PBX.

R, r *Pulse (rotary) dial subcommand*

Sets the DCM-7 to pulse dialing mode.

T, t *Touch-tone dial subcommand*

Sets the DCM-7 to touch-tone mode.

(,), -, <space>

Enter these symbols to make the phone number easy to read. These entries are ignored by the dialer routine, but are accepted and stored in the dialer memory.

BS *BACKSPACE code*

The BS code is simply an editing feature for the D command. If you are typing a number and make an error, press (BS) to delete the last character typed. If you press (BS) immediately after selecting the D command, a ? will appear to indicate an error condition.

A total of up to 40 digits and symbols that follow the D command can be stored and dialed by the DCM-7. The stored number will be kept in memory until you turn off or reprogram the DCM-7 by entering D or C. Use the list command to confirm the number.

The pulse dialing mode is the default condition and the Modem applies the dialing mode of the previous call if R nor T does not precede the telephone number.

The DCM-7 allows you to mix signaling types in a telephone number. For example, the sequence DR234333PPT-(111)-123-4567 says to pulse dial the number 234333, pause for 4 seconds, then tone dial the number 1111234567. The dashes, parentheses and space are ignored by the DCM-7 during dialing.

If you have problems when using touch-tone and/or the fast dialing rate, your telephone line may not be suitable for these modes. Use rotary dialing and/or the slow dialing rate. Refer to dialing speed commands F and S.

E, e *Echo disable/enable toggle*

This code is used to disable or enable the "echo" function. When enabled, the echo supplies feedback to your computer's display. When disabled, data you send to the DCM-7 will not be echoed to the computer display, including the parameter settings. The display will not show anything, even if you type L. If the echo feature is disabled, the DCM-7 will appear dead, but actually it is working normally.

The default (power-up) setting of echo function is the echo enable.

F, f Fast dialing speed

When you want to tone or pulse dial using faster signaling rates, you can use this command. The F command forces the Modem to dial while in the automatic originate mode at 10 digits-per-second for touch-tone or 20 pulses/second (pps) for pulse dialing. The RATE = S line on the listing will then show RATE = F.

Note: The fast dialing speed command is mainly used in touch-tone dialing. Fast pulse dialing is seldom used. When you experience difficulty in fast pulse dialing, set the rate to slow.

G, g Forced carrier detect toggle

This command is used to turn on and off the forced carrier detect signal (FCD). When the FCD is ON, the DCM-7 issues a forced carrier detect signal to the computer upon power-up, and the CARRIER DETECT indicator lights. When the FCD is OFF, the DCM-7 issues a carrier detect signal to the computer when it detects a true carrier signal on the telephone line and lights up the CARRIER DETECT indicator.

The default condition of this command is set by DIP switches 2 and 6. The G command is disabled when DIP SW 2 is ON. If you input G when the switch is ON, the Modem informs you by showing:

FORCED CD SWITCH IS ON

You can check the status of the FCD at the FCD = parameter listing by using the L command.

I, i Ring/retry change command

This command allows you to change the answer on n rings or retry n times. The I command displays the intermediate menu. When you press **I**, the DCM-7 prompts:

ANSWER ON 1-9 RINGS OR CR FOR NO CHANGE =

The cursor (if used) will be positioned after the = sign and await your input. If you press **ENTER** instead of typing a number, the DCM-7 assumes that you want to keep the already programmed number of rings. Only a number between 1 and 9 or the **ENTER** key is a valid entry. All other entries are not accepted. If you reply to the prompt with an invalid entry, the DCM-7 will echo the key (display the key you just entered, if displayable) and ask the question again.

When you correctly respond to the first prompt, the display shows the next prompt:

RETRY FOR 1-9 TIMES OR CR FOR NO CHANGE =

Here again, only a number in the range 1 to 9 or the **ENTER** key is valid. The prompt is asking you how many times the DCM-7 should try a telephone number before exiting the auto-dialer routine. Enter a value of 2 or greater if you want it to redial the number.

When your response is acceptable, the DCM-7 will return to the command receptive mode, ready to accept the next command.

The DCM-7 will look for a valid carrier tone from the remote modem. If carrier is not detected within 30 seconds, your DCM-7 gives up and prepares for the next try.

L, l List command

The list command is used to review the current state of the DCM-7.

Table 10. List Settings and Related Commands

The screen shows:	Parameter	Related Commands
MODE = A	A (Automatic), M (Manual)	M
TYPE = O	O (Originate), A (Answer)	O, A
F CD = Y	Y (On-line), N (Off-line)	G
SPKR = Y	Y (Monitor speaker on), N (Monitor speaker off)	P
ANSW = 2	1-9	I
DTRY = 1	1-9	I
TEST = N	Y (Self-test on), N (Self-test off)	Q
NUMB =	0-9, T (Touch-tone), R (Pulse), P (Pause), -, (,), space, *, #	D
RATE = S	S (Slow), F (Fast)	S, F
EXIT = 0F	Hex code for abort character	@

The parameters or settings shown above are defaulted when the Modem is initially powered up.

M, m Manual/automatic toggle

The M command is used to switch the DCM-7 from its automatic (defaulted) state to manual state. Each time this command is entered, the value of the MODE = x line on the listing changes from A (automatic) to M (manual) and back again, depending on how many times the M command is used.

O, o Originate mode operation

The Modem will always operate in originate mode when cold-started (initial power-up). Use originate mode when you want to call a time-sharing network, like CompServe. You can also use this mode to force the Modem to automatically dial a telephone number for you while in automatic mode.

This code will change the TYPE = *x* line in the listing to TYPE = O (originate type modem) while the A command changes the line to TYPE = A (answer type modem).

P, p Monitor speaker on/off toggle

Use this command to control the on/off condition of the built-in monitor speaker. Since the Modem powers up with the speaker ON, you can monitor the telephone line signal (dialing tone, ringback tone, busy tone, carrier tone etc.) through the speaker during dialing mode. For quiet dialing, turn the speaker OFF by entering (P). SPKR=*x* line in the list setting will show SPKR=N. Enter (P) again to turn it ON. SPKR=N will change to SPKR=Y.

Q, q Self-test command

This command forces the DCM-7 to enter the self-test mode to “talk to itself” when the X command is issued. With this feature, you will be able to tell if the Modem is functioning correctly. This self-test neither tests nor analyzes the condition of your telephone lines, since data transmitted from the computer is looped back through only the Modem’s circuitry.

When power is first applied, the listing line TEST=N tells you that the Modem is not selected to go into self-test mode. When you input Q, the line reads TEST=Y. The Modem is ready to enter the self-test mode upon exiting the command receptive state with the X command. You can then test to see if typed characters are displayed on the screen.

During the self-test mode, the TRANSMIT DATA and RECEIVED DATA indicators flash almost at the same time everytime you input characters.

To exit self-test mode, input the abort code CTRL O and the Modem goes OFF LINE. To return to command receptive state, enter the wake-up command *.

S, s Slow dialing speed

The slow dialing speed command is used to force the DCM-7 to dial any telephone number with slow timing (RATE = *x* line on the listing reads RATE = S). Slow dialing speed is the default at power-up. While in slow speed mode, the Modem pulse dials at 10 pulses per second and touch-tone dials at 5 digits per second.

X, x Execute programmed command(s)

This command signals the DCM-7 that programming is completed and it is time to go ON LINE (off-hook) and execute your instructions. When the X command is received, the Modem will do one of three things:

1. Enter a waiting state and monitor the telephone lines for an incoming call (auto-answer mode).
2. Seize the telephone lines and monitor for carrier (if in manual originate or manual answer mode) or start the dialing sequences (if in auto-originate mode).
3. Enter the self-test mode in the TEST = Y condition.

Hayes protocol reference **B**

Programming commands

AT **Attention code**

Every command line starts with the attention code. Always enter this code in uppercase letters. Other commands may be typed in lower- or uppercase letters.

CR **Carriage return**

Ends the command line. The Modem does not execute a command until you press **(ENTER)**. The carriage return key is defined as 13 in ASCII value. To redefine it, change the value of register S3.

BS **Backspace**

You can edit a command line with the **(BS)** key, but the attention code at the beginning of a command line cannot be deleted. The **(BS)** key is defined as 08 in ASCII value. To redefine it, change the value of register S5.

+++ **Escape code**

Use the escape code to return to command mode from ON LINE. When you input escape code + + +, the Modem returns to command mode and displays the result code OK. The telephone line will remain connected until you input H0 (ON HOOK command) or Z (Reset command).

The escape character can be redefined with register S2. When you redefine the escape character, do not select characters which are frequently used in the data line.

The escape code is marked off from data by the escape guard time. This guard time is inserted between the last character transmitted and the first character of the escape code. It is also inserted after the third character of the escape code. As a result, the escape code is sandwiched by the escape guard time.

The escape guard time can be redefined with register S12. Its default value is 50 (1 second). When entering the escape code with default values, wait at least 1 second, input + + +, then wait 1 second more before entering the command line. Without the guard time, the Modem cannot recognize the escape code.

To return ON LINE, enter ATO **(ENTER)**.

A, a Manual answer command

When the A command is entered, the Modem goes OFF HOOK and waits for the carrier signal. Use this command to begin computer communication immediately after talking with a friend by phone. In this case, one user should input A while the other uses the dial command D. Any command placed after A will not be executed. If you want to execute other commands, insert the commands before the manual answer command.

Example:

```
AT F1 A ENTER        Wake up!  
                          Select full duplex.  
                          Wait for a carrier tone.
```

D, d Autodial command

The D command sets the Modem to originate a call without using a telephone. D can be followed by the dialer codes shown in Table 11. When used alone, D sets the Modem to auto-originate mode.

Table 11. Dialer Codes

Codes	Function
0-9	Used for the telephone number.
(,), -, space	Used to make the telephone number readable.
*, #	Used only in touch-tone dialing mode.
P	Sets the Modem to pulse dialing mode.
T	Sets the Modem to touch-tone dialing mode.
R	Changes the Modem from originate mode to answer mode once communication is established.
, (comma)	Sets the Modem to pause while dialing (can be used after the access code).
; (semicolon)	Returns the Modem to command mode after dialing.

Example:

```
AT DT(111)123-0009 ENTER    Wake up!  
                                  Originate a call by touch-tone dialing.
```

After dialing the number, the Modem waits for a carrier signal. When a carrier is not detected within a time set by register S7, the Modem automatically releases the line and sends the result code:

```
NO CARRIER (or 3)
```

When a carrier signal is detected, the Modem goes ON LINE and sends the result code:

CONNECT (or 1)

The result code ON/OFF condition is determined by the Q command (DIP Switch 4). The type of the code is determined by the V command (DIP Switch 3).

R, r Reverse mode command

Use this command to call and establish communication with an originate-only modem. When R is entered, the Modem enters answer mode automatically after it dials the telephone number.

Example:

AT D(111)123-0009R

Wake up!
Originate a call.
Change to answer mode and wait for carrier.

P, p Pulse dialing (default)

The P command sets the Modem to pulse dialing mode. If your phone line is rotary type, input P at any point in the telephone number sequence. You can change to pulse dialing mode from touch-tone dialing mode by entering ATP any time you want.

When the type of dialing (pulse or touch-tone) is not specified in the command line, the Modem defaults to the type used in the last command. Pulse dialing is fixed at 10 pps (pulses per second).

T, t Touch-tone dialing

When T is added to the dial command, the Modem is set to touch-tone dialing mode. Use register S11 to change the speed of touch-tone dialing.

, Pause

When you use the Modem in an office or anywhere that requires an access code to get an outside telephone line, you will need to add a pause before dialing the number that follows. Insert the , command between the access code and the telephone number.

The pause duration is determined by register S8. The default pause duration of 1 comma is 2 seconds. You can accumulate the duration by using multiple commas.

; **Return the Modem to command mode**

Place this command code at the end of the dial command line when transmitting information to a telephone order service or bank service that recognizes touch-tones. By inserting the semicolon, you can enter a long command line before establishing communication with another modem.

Example:

The screen shows:	Command line	Function
	AT D T(111)123-4567; ENTER	Wake up! Originate the call by touch-tone dialing. Return to command mode.
OK	AT D 43278 #; ENTER	Transmit the ID number. Return to command mode.
OK	AT D8881 #; ENTER	Transmit the password. Return to command mode.
OK	AT D 273*65 #; ENTER	Enter the transaction. Return to command mode.
OK	AT H0 ENTER	Terminate the call.

A/ **Repeat the command line (Redial command)**

The Modem repeats the command line stored in the command buffer when repeat command A/ is entered. Use this command to dial again when you get a busy signal or if a carrier signal is not detected. There is no need to input the attention code AT or carriage return before or after the repeat command. Just enter A/.

The command buffer is cleared under the following conditions.:

- New command line beginning with AT is entered
- Reset command Z is entered
- Modem is switched OFF

O, o **On-line command**

The on-line command returns the Modem to on-line mode from command mode (reverse of the escape command). Use this command to return to the on-line state after executing the local command.

Z, z Reset command

This command clears the DCM-7 command buffer and resets all commands and registers to the default values. When you have changed the commands and registers from default condition, use this command to return to the default settings. It will save you from cycling the power switch OFF and ON.

E, e Echo command

This command is used to disable or enable the command echo function. Enter E1 to echo the command line to verify that the Modem is accurately receiving the commands sent to it. Enter E0 when you do not want to echo the command line.

When the echo feature is disabled (E0), the Modem will appear dead, but actually it is working normally. The default setting of this command is set by DIP switch. For example, if DIP switch 5 is OFF, the default is E1. If the switch is ON, the default is E0.

F, f Full/half duplex

Selects full- or half-duplex communications mode. F1 sets the Modem to communicate in full-duplex mode that only echoes received data when ON LINE (default). F0 sets the Modem to communicate in half duplex. The Modem echoes both received and transmitted data to the display during ON LINE.

Q, q Result codes ON/OFF command

Determines whether the result codes will be sent to the screen. Enter Q0 to display result codes and Q1 if the codes are not to be sent.

V, v Result codes mode selector

Selects the type of result codes displayed. V0 is used for numeric codes and V1 is for verbal codes.

Note: The default values of commands Q and V are set by DIP switches.

C, c Transmitter ON/OFF command

The C command sets the Modem's transmitter carrier signal ON or OFF. When C1 is entered, the transmitter is switched ON. The carrier signal is ON when the Modem originates or answers a call or connects to the remote modem. Otherwise, it is OFF.

When C0 is entered, the transmitter is switched OFF and remains OFF until C1 or reset command Z is entered. As long as the transmitter is OFF, the Modem does not issue carrier even when it detects the answer modem's carrier tone during originate mode operation. For further information, refer to Data line monitoring mode operation later in this chapter.

H, h Hook switch control

Controls the hook switch of a telephone. The H0 setting is comparable to the condition of the handset resting on the hook while the telephone line is not in use. In the H1 setting, the handset is off the hook and the telephone line is in use.

Use the H0 setting for normal operation. When originating or answering calls, the Modem controls off hook condition automatically.

M, m Speaker Control

Controls the built-in speaker. Use M1 (default) to monitor a call in progress. You can monitor signals on the telephone line such as a dial tone, ring-back tone, busy signal and carrier tone. The speaker turns OFF when the Modem recognizes a carrier signal and sends a CONNECT result code.

When you want to continue monitoring the data communication, use M2 instead of M1. Or, input M0 if you do not want to use the speaker function at all.

Registers

S0 Defines the rings for answering a call

The value of register S0 determines the number of times the phone will ring before the Modem answers a call. Input any decimal number greater than 0 to set the Modem to auto-answer mode. If the value is set to 0, the Modem will not answer a call. Since the default value of S0 is preset at 0, use the prescribed syntax (refer to **Command syntax**, in Chapter 3) to change the value when you use the Modem in auto-answer mode.

When DIP Switch 6 is OFF, the Modem will power-up in auto-answer mode with S0 = 1. Answer command A disregards the S0 value since it enters answer mode immediately.

S1 Counts the rings

The value of S1 increases each time the phone rings and clears if no rings occur within about 8 seconds of the last ring. This will operate only if the value of S0 is greater than 0.

S2 Escape code definition

S2 stores the ASCII value of the escape code character. The default value is set to 43 (+). To change the escape function key, change the code using the $Sx = n$ syntax. The value must be a decimal number in the range 0 to 127. If you enter a value out of this range, the escape will be disabled.

S3 Carriage return code definition

S3 stores the ASCII value of the carriage return character. Enter a decimal number in the range 0 to 127 when you want to change the carriage return function key. The default value is 13.

S4 Line feed code definition

S4 stores the ASCII value of the line feed character. The value is predefined as 10 (default). You can redefine the value by inputting the new ASCII character code as a line feed function key. The character is output after the carriage return only when the verbal result code is supported (V1). The value must be a decimal number in the range 0 to 127.

S5 Backspace code definition

S5 stores the ASCII value of the backspace character code. The default value (decimal) is set to 8. To change the backspace function key, select a value between 0 and 32 or 127. These numbers do not include printable ASCII characters 33-126.

S6 Dial tone wait time definition

Register S6 determines the wait time for receiving a dial tone. This wait time is defined as the length of time it takes to input the first digit of the phone number after you pick up the telephone receiver. The default value is set at the minimum wait time of 2 seconds, which is regulated by the FCC. To change the wait time, input the number of seconds you want. If a value less than 2 is programmed into S6, it will still wait for 2 seconds.

S7 Carrier tone wait time definition

The carrier tone wait time is defined as the length of time the Modem can wait for a carrier tone transmitted from the remote modem. The value of S7 determines this wait time. If the Modem cannot receive a carrier tone within the restricted time, it hangs up and displays result code NO CARRIER or 3 when Q0 is supported, then returns to command mode. It is defaulted to 30 seconds. To change, input the number of seconds you wish.

Once the carrier tone is detected, the Modem displays CONNECT or 1 and it goes ON LINE.

S8 Pause (,) duration definition

To access an outside line through a PBX or when using a special telephone service, the comma (,) is used to pause after dialing an access code. The value of register S8 determines pause duration for this comma. Defaulted to 2 seconds, it can be changed by inputting the desired number of seconds.

S9 Carrier detect response time definition

The value of register S9 determines the length of time (carrier duration) which the Modem takes to recognize the carrier tone and go ON LINE. As the value increases, the possibility of detecting a false carrier from noise decreases. The default value of S9 is set at 6 with the unit of 1/10 second (0.6 seconds). To change it, input the desired duration times 10.

DO NOT confuse S9 with the carrier tone wait time definition, S7.

S10 Carrier loss time definition

Register S10 decides how long the Modem waits for carrier before disconnecting the line. When the Modem does not receive a carrier tone within the time fixed by the S10 value, it disconnects the telephone line.

When you set the value to 255, the Modem assumes the carrier is always present and ignores carrier detect. It is defaulted to 7 (0.7 seconds). To change, input the desired number of seconds times 10.

S11 Touch-tone dialing speed definition

The value of S11 defines the duration and spacing of the tones during touch-tone dialing. The default value of S11 is 70 in units of milliseconds. This sets the dialing rate to 7.14 digits per second. The dialing rate of 5 (10) digits per second can be obtained by applying the value 100 (50) to S11. The minimum value for reliable dialing is 50 and the maximum value is 255.

Register S11 does not affect the pulse dialing speed; it is fixed at 10 pps.

S12 Escape code guard time definition

The value of S12 determines the escape code guard time. This escape guard time is specified to 20 minimum and 255 maximum in units of 1/50 second. The default value is 50, that is, 1 second.

Note: Beware that the small guard time you assign should be greater than the time required to transmit one of the 3 escape characters.

S16 Self-test toggle

The self-test mode forces the Modem to “talk to itself.” Apply value 1 to S16 when you want to set the Modem to self-test mode. Using this feature, you will be able to tell if the Modem is functioning correctly.

When the Modem is in self-test mode, the internal switches are selected such that data transmitted from the computer is looped back to the receiver and processed just as if it were in communications over the telephone lines. Keys entered from the computer are echoed to the screen.

Since the Modem goes off-hook during the test, **be sure to disconnect the wall jack phone line cord from the wall jack before executing a self-test.**

To set the Modem for self-test mode, type:

AT S16=1 D Self-test mode ON.
Originate mode.

To set the Modem for self-test mode in answer mode, type:

AT S16=1 A Self-test mode ON.
Answer mode.

Data line monitoring

The DCM-7 can be used to monitor a data line up to 300 bps as shown in the figure below. To accomplish this monitoring mode, the Modem's carrier transmitter should be turned off and loss of carrier condition should be ignored.

For originate mode, input:

AT C0 S10=255 D

For answer mode, input:

AT C0 S10=255 A

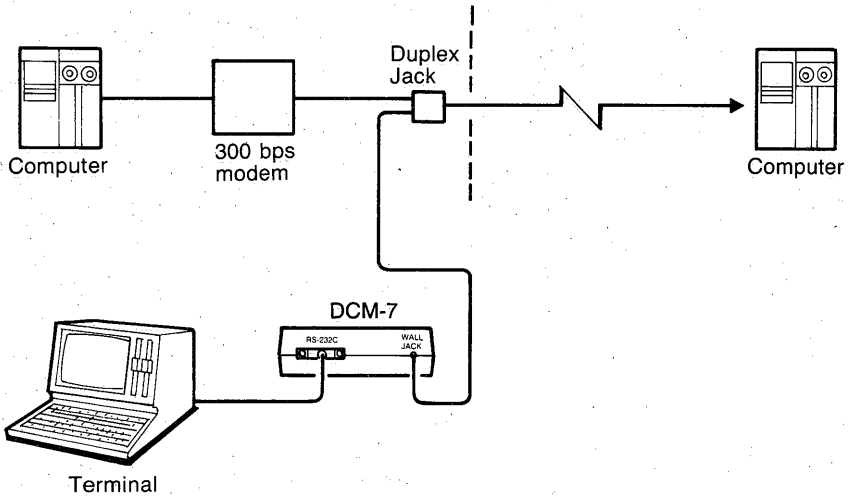

Connecting the DCM-7 C

Your DCM-7 is Bell System 103 compatible, connecting to the telephone lines via a modular connector. The RS-232C input/output of the Modem interfaces directly with RS-232C-equipped Tandy computers.

Telephone connections

Please note that each product connected to the telephone line places a certain load on the line. This is designated as the unit's "Ringer Equivalence Number."

When using more than one product on the line, total all the ringer equivalence numbers. If they total more than 5, your phone may not ring. In rural areas a total of 3 may impair ringer operation. To be sure, check with your local telephone company.

The registration number as well as ringer equivalence number appears on the bottom of the unit.

Warning: The Modem must not be connected to:

- Coin-operated phones
- Party-line phones

The way you connect the DCM-7 to a telephone depends on how your telephone is connected to the wall. (If you plan to use the DCM-7 in automatic mode only, you do not need to use a telephone.)

Single-line

1. Remove your telephone's plug from the modular wall jack and insert it in the PHONE jack on the rear of the Modem.
2. Plug the Modem's WALL JACK phone line cord into the modular wall jack.

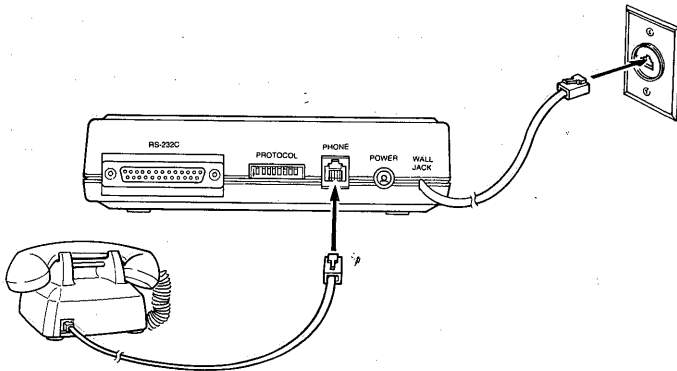

Figure 6. Modular Telephone Connection

Connecting the DCM-7

If your telephone has the older style, four-prong connection, use an adapter (Radio Shack Cat. No. 279-360) to connect it to your DCM-7 as shown in Figure 7.

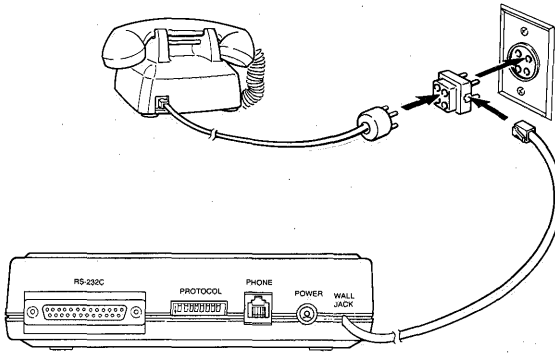

Figure 7. Connection to a Four-Prong Jack

If your telephone is wired directly to the wall, the jacks and adapters necessary for the conversion can be purchased from your nearest Radio Shack store. Or, you may contact the telephone company to have modular connections installed. The telephone company is authorized to charge you for the installation of such jacks. The U.S.O.C. number for the plug connection is RJ-11C.

Multi-line

The DCM-7 Modem can be used with a multi-line telephone, but you may need a multi-line adapter (43-271), a hardware modification to the Modem, or both.

If you use a multi-line adapter only, the HOLD button on an extension phone can interfere with communication if someone presses it. To avoid this problem, have a qualified Radio Shack service technician modify the DCM-7.

Radio Shack has several adapters that can be used for connecting the DCM-7 to multi-line telephones. Contact your Radio Shack Computer Center or store for details.

Computer connections

The DCM-7 uses the RS-232C standard serial interface cable to connect to your computer. The table below provides the cable requirement for Tandy computers. If more detailed information is needed, refer to your computer's owner's manual.

Table 12. Modem-to-Computer Cables

Computer	Cable Catalog No.
Model I	26-1145
Model III/16	26-4403
Model III/4/4D/4P/12/16B/16B HD DT-1/DT-100/100	26-1408
Tandy 102/200/600/1000/1200/1200HD/2000/6000	26-1408
Tandy 3000	26-1399

1. Plug the appropriate end of the interface cable into the RS-232C standard DB-25 jack on the rear of the Modem.
2. Plug the other end of the cable into the computer's DB-25 jack.

For the following computers, you'll need option boards which contain an RS-232C interface to connect your DCM-7. Contact your Radio Shack Computer Center for details.

Table 13. Computer Option Boards

Computer	Board	Catalog No.
Model I	RS-232C Interface Board with cable	26-1145
Tandy 1000	RS-232C Option Board	25-1006
Tandy 1200	Captain Multifunction Board	25-3061

Power source

Insert the AC adapter's plug into the AC power jack on the rear of the Modem. Plug the adapter into an electrical wall outlet or an approved power strip.

Be sure to connect the adapter to the Modem before you plug the adapter into the wall outlet. Otherwise, damage to the adapter could result.

Note: Use the supplied adapter only. Another type of adapter could damage the Modem.

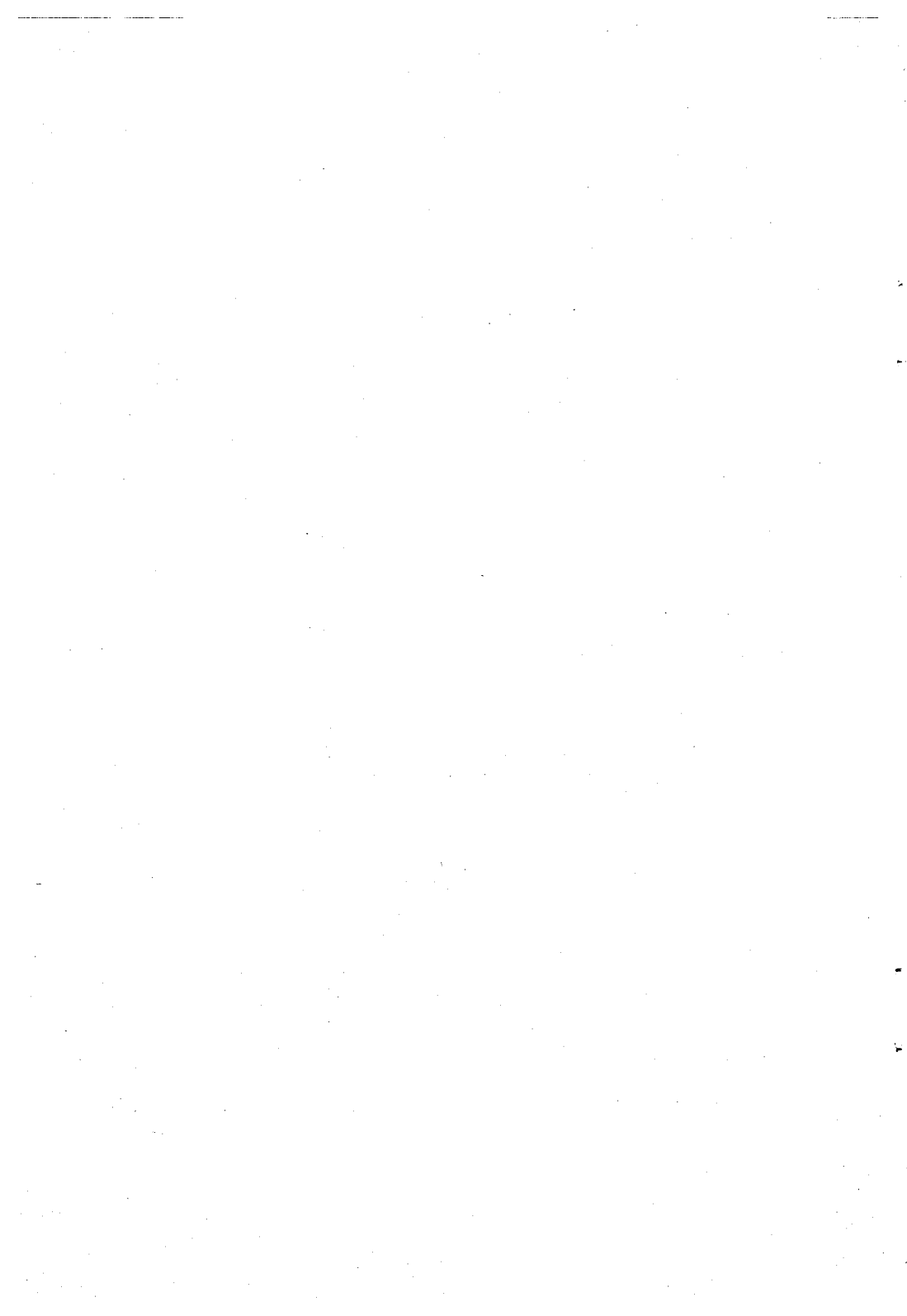

XENIX operations **D**

Your DCM-7 is configured to operate with a Tandy 6000 running the XENIX operating system (Version 3.1 or later). This section will be helpful in explaining how using the DCM-7 with XENIX differs from operations in other modes.

Always automatic answer mode

Set the DIP switches as illustrated and power up the DCM-7. From a power-on condition, the DCM-7 will power up into the call-waiting state and monitor the telephone line for an incoming call. When DTR (Data Terminal Ready) is asserted (this happens when log-ins are allowed using the enable command), the Modem will pick up the call and assume always auto-answer, 10-bit word operation.

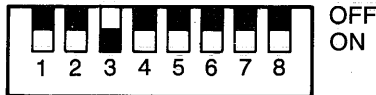

Dial out

Set the DIP switches using the same settings as in always automatic answer mode operation and power up the DCM-7. Program the Modem to automatically dial a call by using the command:

dialHAYES

Refer to your XENIX system's documentation for more information on using a modem with XENIX.

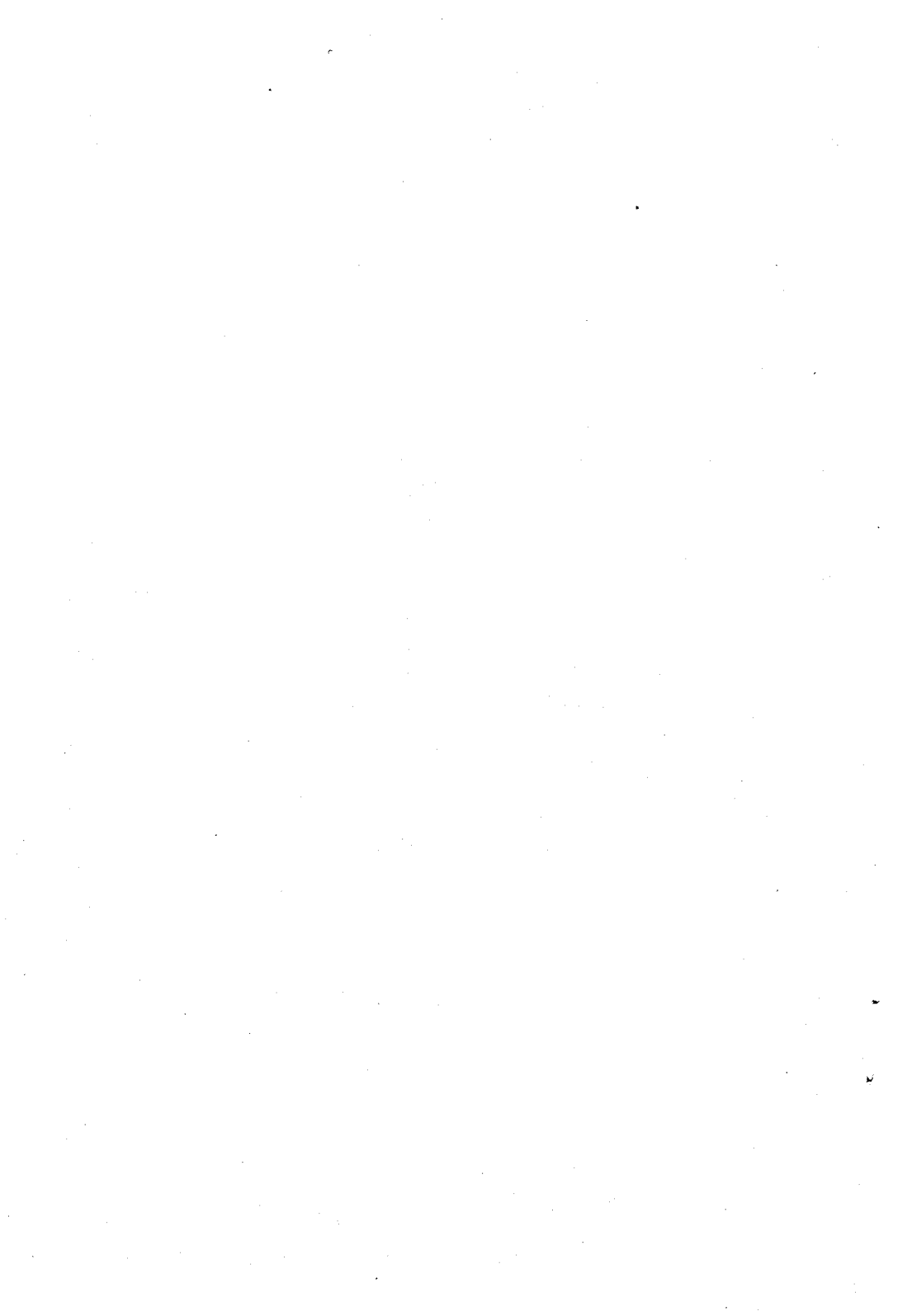

Troubleshooting **E**

When you have problems transmitting data (garbled data, intermittent errors, etc.), there are a few checks you can make before taking the unit to a Radio Shack service technician:

- Phone connection is clean and noise-free.
- No one is talking on the telephone line.
- Phone and all extensions are on hook.
- Operation speed is 300.

The only maintenance your DCM-7 requires is a periodic checking of cables and connections. When you experience data transfer problems, first check the cable connections. Then run the self-test. If you still experience problems, check with your Radio Shack Computer Center or store.

Precautions

Lightning. Your Radio Shack phone product has built-in protection circuits that meet or exceed FCC requirements to reduce risk or damage from surges in telephone line current. However, an incident such as a lightning strike near, or directly to, the telephone line may cause an excessive surge of voltage that can damage the phone device. Lightning damage is uncommon, but can occur to phone and other electronic devices. If you are concerned about it or live in an area with frequent and/or severe electrical storms, it is suggested that you unplug the electronic products during storms.

It is very unlikely ... but if your DCM-7 causes problems on the phone line, the telephone company has the right to temporarily discontinue your service. If this happens, the telephone company will notify you and give you a chance to have the problem corrected. Also, the telephone company has the right to make changes in their lines and/or equipment. If these changes affect your DCM-7 or require changes in its connection, the phone company will notify you in writing so that you can take the necessary steps to ensure uninterrupted service.

Analog loop self-test

When you cannot locate the source of your problem, test the Modem with the Q command (or S16=1 in Hayes protocol mode). This test causes the data sent from your computer to be looped back to the receiver, thus letting you know whether the Modem is functioning properly. The analog loop self-test does not test nor analyze the condition of your telephone circuits.

Multi-line phone operation

The DCM-7 Modem has an internal configuration option which allows the Modem to be used with multi-line telephones. This option must be performed by a qualified Radio Shack service technician.

With this option, the internal circuitry can be configured to signal a local network that there is a MODEM on the line instead of a telephone. Unless the Modem is modified internally, the local network will start flashing the BUSY indicator on the multi-line telephone when the Modem seizes the line.

Specifications **F**

Performance

Operation modes

Tandy protocol
Hayes protocol
Full or half duplex
Automatic answer/originate
Manual answer/originate

Receive frequencies

Answer

Mark 1270 Hz
Space 1070 Hz

Originate

Mark 2225 Hz
Space 2025 Hz

Transmit frequencies

Answer

Mark 2225 Hz
Space 2025 Hz

Originate

Mark 1270 Hz
Space 1070 Hz

Transmit level

- 13 dBm

Receive sensitivity (NO ERROR)

- 35 dBm

Carrier detect sensitivity

- 40 dBm

Baud rate

300 bps

Output impedance

600 ohms

Telephone dialer (auto-originate mode)

Pulse dialing

Dialing rate (slow), 10 pps
Breaking ratio (slow), 60%
Interdigital pause (slow),
820 mS

Touch-tone dialing
(Tandy/Hayes)

Duration of signals (slow),
100 mS/70 mS
Interdigital time (slow),
100 mS/70 mS

Physical/environmental

Electrical requirements

15 VAC @ 600 mA
AC adapter supplied

Operating temperature

55°F-85°F (12.8°C-29.4°C)

Humidity

Operating environment

90% relative humidity (non-
condensing)

Storage

90% (non-condensing)

Specifications

Dimensions (H × W × D)

1-3/4" × 6-7/10" × 10-1/4"
(45 × 170 × 260 mm)

Weight

24 oz (680 g)

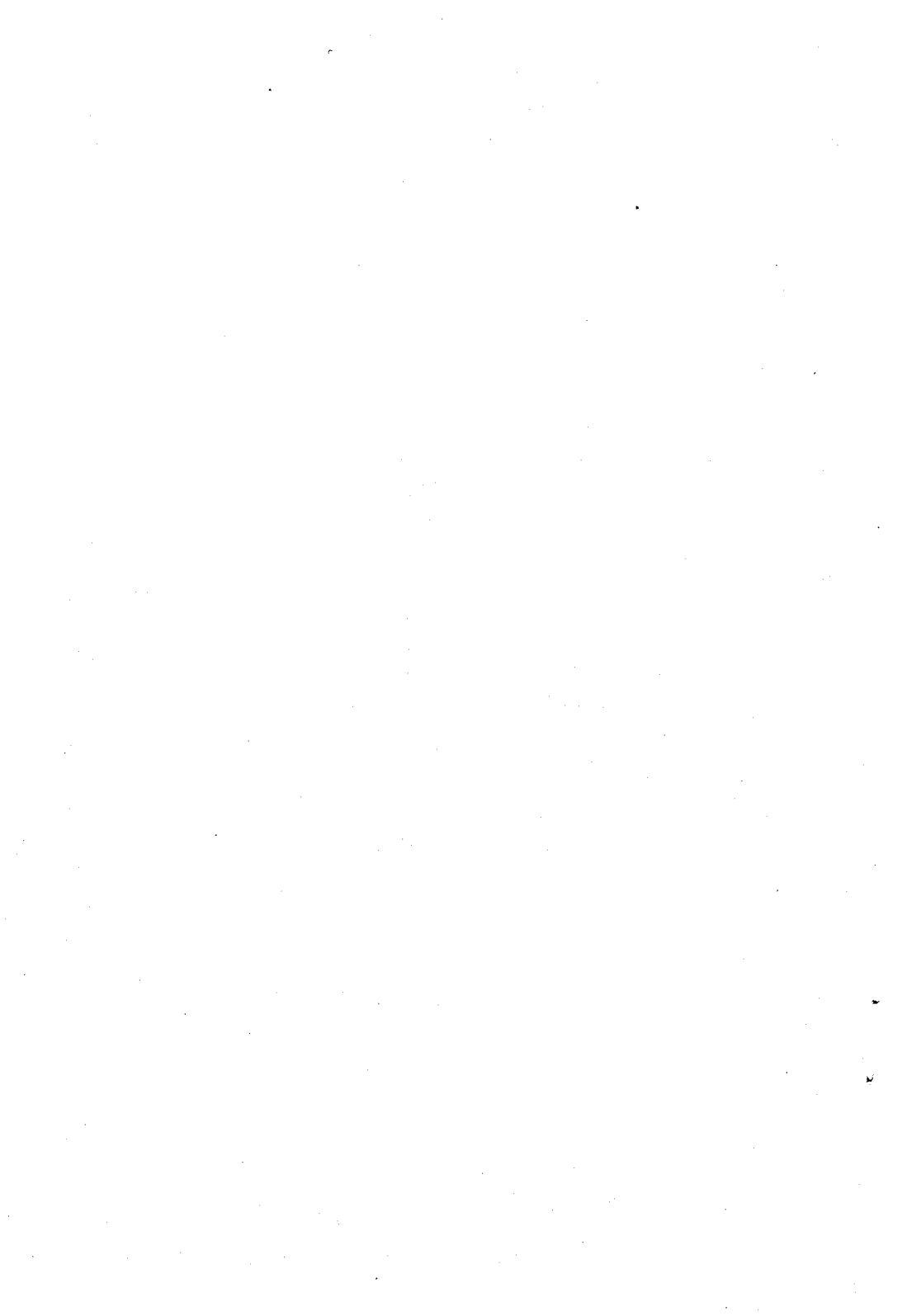

Index

- Abort character...15, 18, 31, 32, 36
- Aborting the on-line mode.....18-19
- Analog loop.....17, 37, 47, 55
- Answer mode, for Hayes
 - protocol.....7-8, 23, 40
 - programming of.....40
 - DIP switches, settings of.....7-8
- Answer mode, for Tandy
 - protocol.....5-7, 9, 14, 33
 - automatic.....11, 15-16, 18
 - manual.....11, 14-15, 36
 - DIP switches, settings of.....5-7
- Attention code.....9, 21, 23, 39
- Autodial command, for Hayes
 - protocol.....21, 23, 40
- Backspace code.....23, 39, 45
 - for Hayes protocol.....23, 39
 - redefining.....24, 45
 - for Tandy protocol.....34
- Bps.....8, 57
- Carrier detect..3, 6-8, 17, 24, 45-46
 - loss time, redefining.....24, 46
 - indicator.....3
 - response time,
 - redefining.....24, 46
 - wait time, redefining.....24, 45
- Carriage return.....23, 39
 - code definition, in Hayes
 - protocol.....45
 - See also registers, changing the value
- Carrier tone.....14, 18, 45-46
- Carrier tone wait time.....45
- Clear memory command.....33
- Command buffer,
 - clearing of.....43
- Command codes.....32-38, 39-47
 - programming in Hayes
 - protocol.....21-22
 - table of.....23
 - parameters, table of.....22
 - programming in Tandy
 - protocol.....11-17
 - table of.....31
- Command mode, returning to.....42
- Command receptive state.....12, 32
- Command syntax.....25
- Commands with parameters.....22
- Communications protocol.....8
- Connecting the computer.....51
 - optional boards.....51
- Connecting to a power source.....51
- Connecting to the telephone...49-50
 - single-line connection.....49-50
 - multi-line connection.....50
- CTRL O.....15, 17, 32
- Data terminal ready.....6
 - indicator.....3
 - loss of.....18
- Dialer codes.....33, 40
- Dialer programming mode.....33
- Dialing speed.....35, 38
- DIP switches, setting of.....5-8
 - for Tandy protocol,
 - table of.....6
 - for Hayes protocol,
 - table of.....8
- Echo disable/enable.....7, 34, 43
 - for Hayes protocol.....7, 43
 - for Tandy protocol.....34
- Electrical specifications.....57
- Environmental specifications..57-58
- Escape code.....23, 39
 - redefining.....45
- Escape guard time.....39, 46
- Execute command.....38
- Fast dialing speed.....35, 36
- Forced carrier detect.....6-7, 8, 35
- Forced data terminal ready.....6, 8

Index

- Full duplex.....43
- Half duplex.....43
- Hayes protocol.....7-8, 9, 21-28, 39-48
 - changing the register value.....25
 - checking the register value.....25
 - dialer codes.....40
 - DIP switch settings, table of.....8
 - programming
 - commands.....22-23, 39-44
 - register commands.....24-25
 - registers.....24, 44-47
 - result codes.....26
 - sample programming session.....21
 - Hook switch control.....44
- Line feed code.....45
- Logging on.....13, 26-28
- Loss of carrier.....18
- Loss of data terminal ready.....18
- Maintenance.....55
- Manual mode
 - operations.....11, 36, 40
 - answering the phone.....14-15
 - making a call.....15
- Multi-line telephones.....50, 56
 - configuring the modem.....56
 - connecting the modem.....50
- Numerical result codes.....7, 8, 22, 26
- Off-hook indicator.....3
- On-line command.....42
- On-line mode, aborting.....18
 - loss of carrier.....18
 - loss of data terminal ready...18
 - receiving a long space.....19
 - transmitting the abort character.....18, 32
- Originating a call.....37
- Pause command, in Hayes protocol.....41
 - defining the duration.....46
- Pause flag, in Tandy protocol....33
- Performance specifications.....57
- Phone jack.....4, 49
- Power jack.....4, 51
- Power source.....51
- Programming commands See command codes
- Pulse dialing.....33, 41
- Received data indicator.....3
- Registers.....24-25, 44-47
 - changing the value.....25
 - checking the value.....25
- Repeat command.....42
- Reset command.....43
- Result codes
 - for Tandy protocol.....19
 - for Hayes protocol.....7, 8, 26
 - mode selector.....43
 - ON/OFF toggle.....43
- Reverse mode.....41
- Ring/retry.....16, 17, 35
- Rotary dialing See pulse dialing
- RS-232C cables, for connecting the modem to a computer.....51
- RS-232C standard
 - DB-25 jack.....4, 51
- Schematic.....59
- Self test mode.....17, 37, 55
 - programming in Tandy protocol.....17, 37, 55

programming in Hayes	
protocol.....	47, 55
Slow dialing command.....	38
Specifications.....	57-58
Terminal ready indicator.....	3
Touch-tone dialing.....	23, 34, 41
redefining the speed of.....	46
Transmit data indicator.....	3
Transmitter carrier signal.....	43
Troubleshooting.....	55
True carrier detect.....	6, 8
True data terminal ready.....	6, 8
Valid dialer codes.....	33-34, 40
Verbal result codes.....	8, 22, 26, 43
Wake-up command.....	9, 11, 18, 32
Wall jack.....	4, 49
Wait for ring, changing the value	
of.....	44
XENIX operating systems.....	53
answering the phone.....	53
making a call.....	53

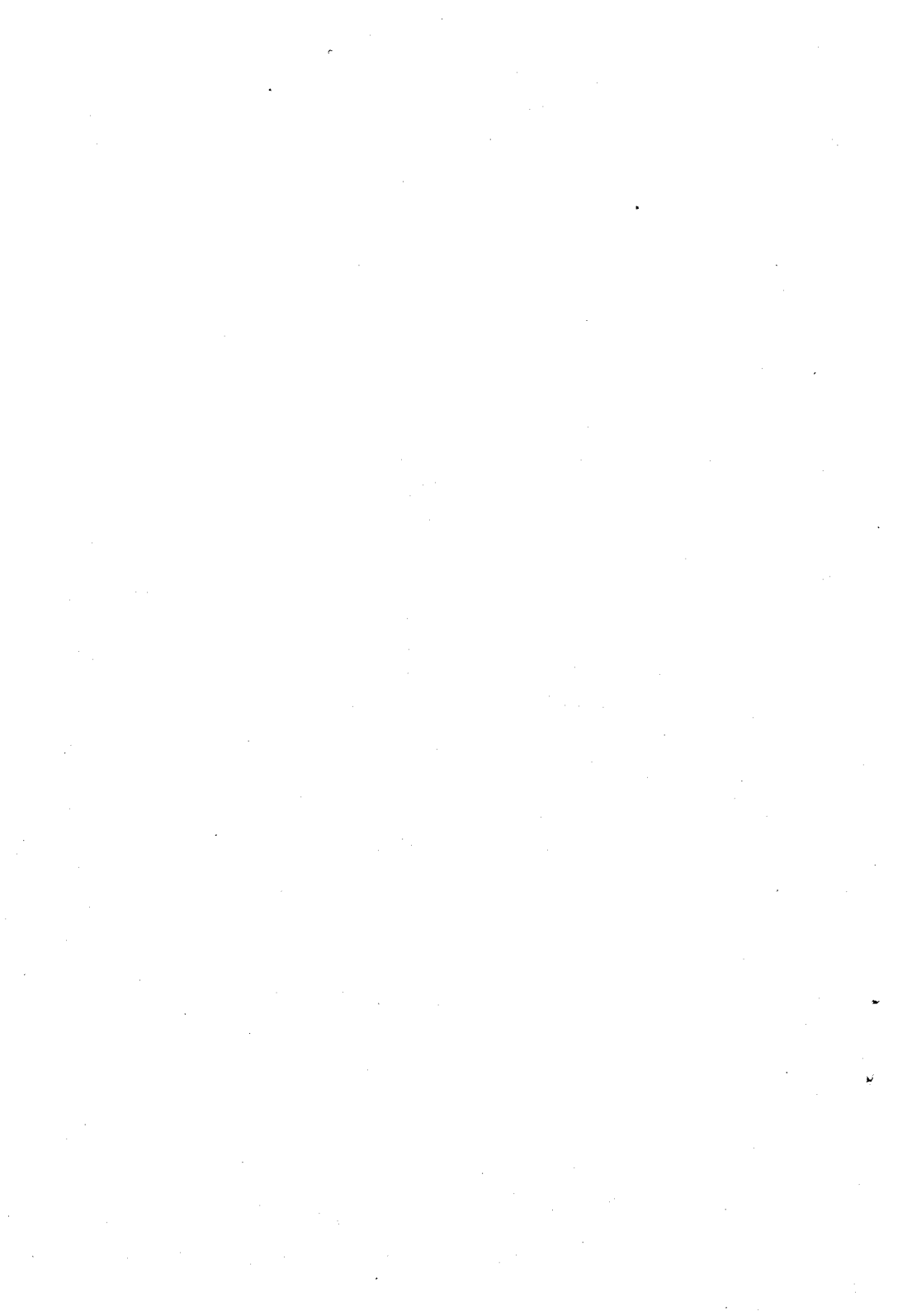

SERVICE POLICY

Radio Shack's nationwide network of service facilities provides quick, convenient, and reliable repair services for all TANDY/Radio Shack computer products, in most instances. Warranty service will be performed in accordance with Radio Shack's Limited Warranty. Non-warranty service will be provided at reasonable parts and labor costs.

Because of the sensitivity of computer products, and the problems which can result from improper servicing, the following limitations also apply to the services offered by Radio Shack:

1. If any of the warranty seals on any Radio Shack and Tandy computer products it sells are broken, Radio Shack reserves the right to refuse to service the product or to void any remaining warranty on the product.
2. If any computer product purchased from Radio Shack has been modified so that it is not within manufacturer's specifications, including, but not limited to, the installation of any non-Radio Shack parts, components, or replacement boards, then Radio Shack reserves the right to refuse to service the product, void any remaining warranty, remove and replace any non-Radio Shack part found in the product, and perform whatever modifications are necessary to return the product to original factory manufacturer's specifications.
3. The cost for the labor and parts required to return the computer product to original manufacturer's specifications will be charged to the customer in addition to the normal repair charge.

**CUSTOM MANUFACTURED FOR RADIO SHACK
A Division of Tandy Corporation**

FORT WORTH, TEXAS 76102

5A6

**Printed in Taiwan
811017400A**